



US00D523820S

(12) **United States Design Patent**
Sweeney

(10) **Patent No.:** **US D523,820 S**
(45) **Date of Patent:** **** Jun. 27, 2006**

(54) **INTERCONNECT FOR ELECTRICALLY
CONNECTING PLURAL ELECTRICALLY
CONDUCTIVE NEUTRAL BARS IN FIXED
SPACED-APART RELATIONSHIP**

(75) Inventor: **Thomas M. Sweeney**, Cincinnati, OH
(US)

(73) Assignee: **IlSCO Corporatio**, Cincinnati, OH (US)

(**) Term: **14 Years**

(21) Appl. No.: **29/233,349**

(22) Filed: **Jun. 30, 2005**

Related U.S. Application Data

(62) Division of application No. 29/170,701, filed on Nov. 12,
2002, now Pat. No. Des. 509,801.

(51) **LOC (8) Cl.** **13-03**

(52) **U.S. Cl.** **D13/154**

(58) **Field of Classification Search** D13/153,
D13/154, 155, 156; 439/362, 365, 367, 476.1,
439/478, 527, 528, 606, 731, 901; D8/354;
174/6, 51, 40, 135

See application file for complete search history.

(56) **References Cited**

U.S. PATENT DOCUMENTS

2,909,757 A * 10/1959 Speck 439/723
3,757,170 A * 9/1973 Kobryner 361/644

4,231,633 A * 11/1980 Luke et al. 439/723
D291,406 S * 8/1987 McNeese D8/323
D298,213 S * 10/1988 Iati D8/354
D337,510 S * 7/1993 Nasca D8/354
5,901,028 A * 5/1999 Hamard 361/129
6,459,570 B1 * 10/2002 Buchanan 361/648
6,666,729 B1 * 12/2003 Takamura et al. 439/723
2004/0072470 A1 4/2004 Lang

* cited by examiner

Primary Examiner—Holly Baynham

Assistant Examiner—Cynthia M. Chin

(74) *Attorney, Agent, or Firm*—Wood, Herron & Evans,
LLP

(57) **CLAIM**

The ornamental design for an interconnect for electrically
connecting plural electrically conductive neutral bars in
fixed spaced-apart relationship, as shown and described.

DESCRIPTION

FIG. 1 is a perspective view of the front, right side, and top
of an interconnect for electrically connecting plural electri-
cally conductive neutral bars in fixed spaced-apart relation-
ship incorporating my new design;

FIG. 2 is a front elevational view thereof;

FIG. 3 is a right-side elevational view thereof, with the
left-side elevational view being a mirror image of FIG. 3;

FIG. 4 is a rear elevational view thereof;

FIG. 5 is a top plan view thereof; and,

FIG. 6 is a bottom plan view thereof.

1 Claim, 1 Drawing Sheet

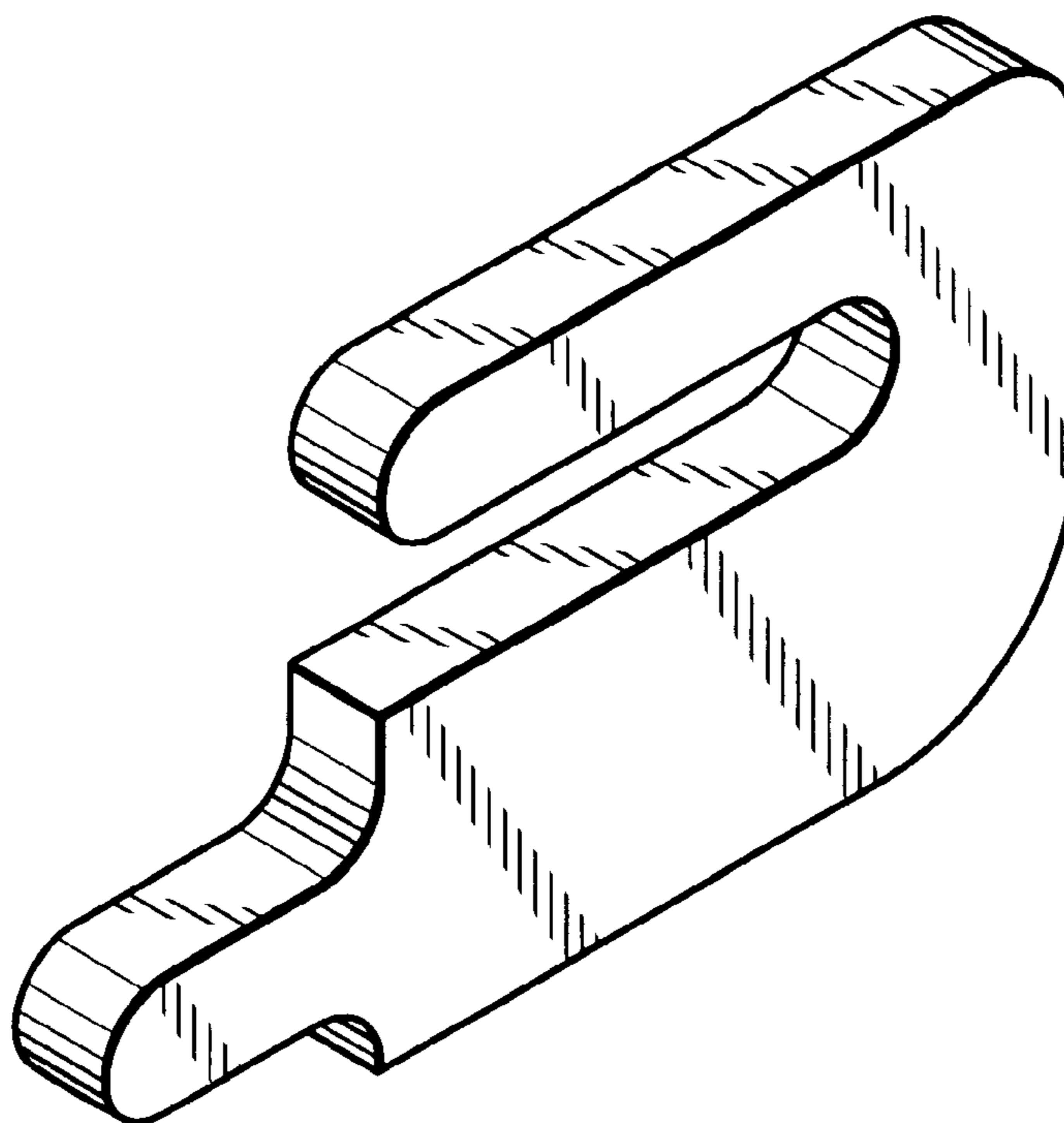

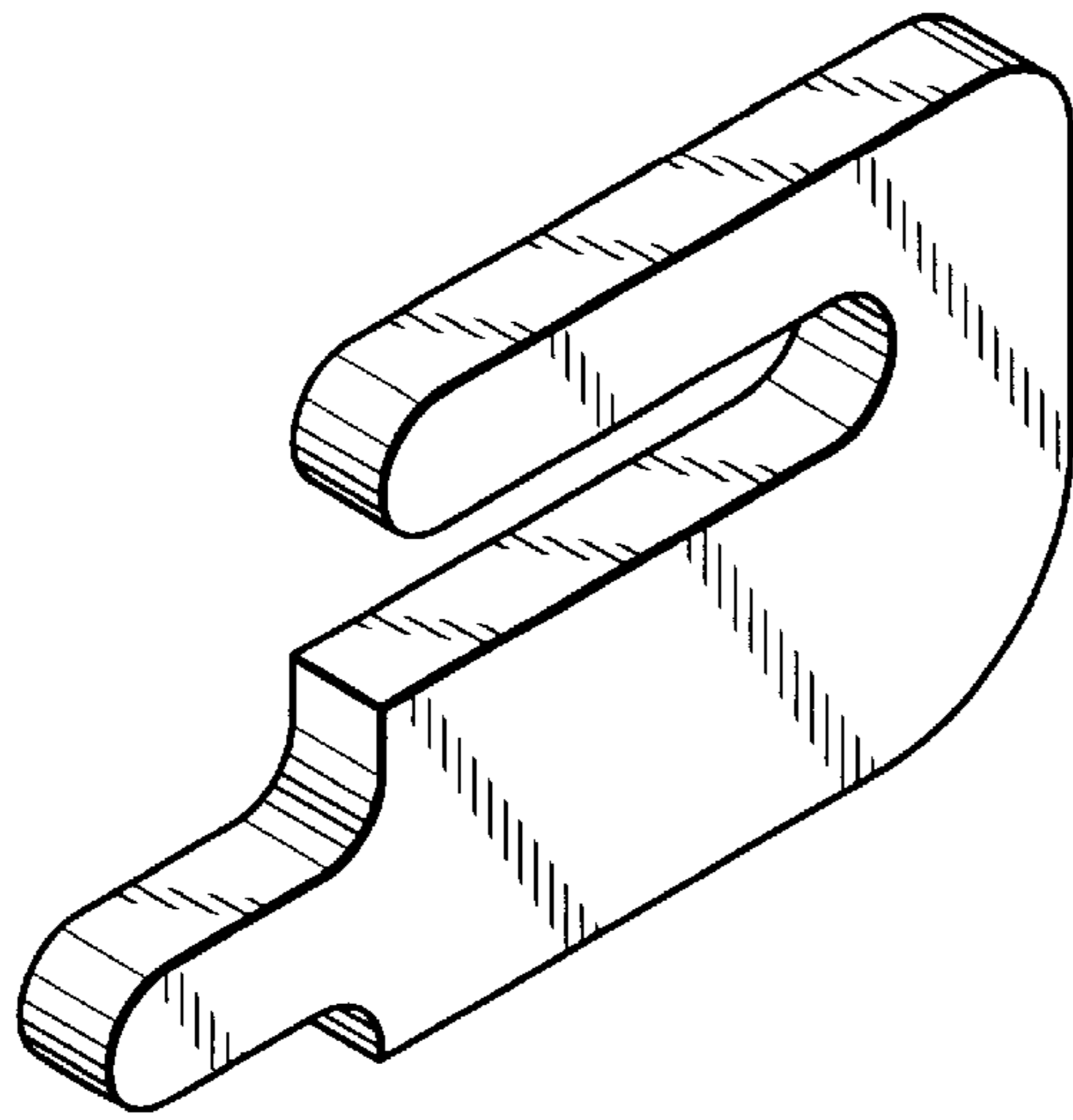

FIG. 1



FIG. 2

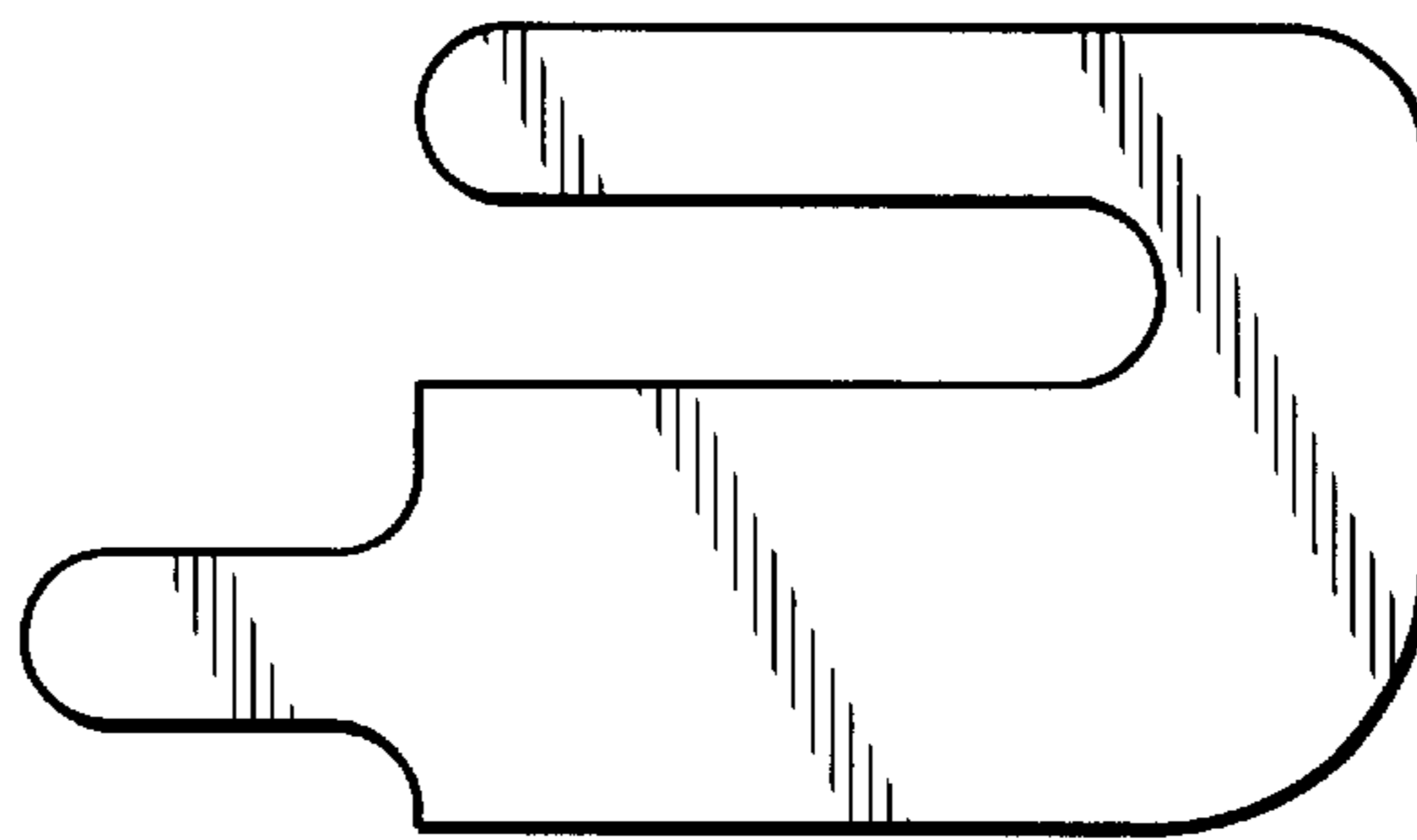

FIG. 3

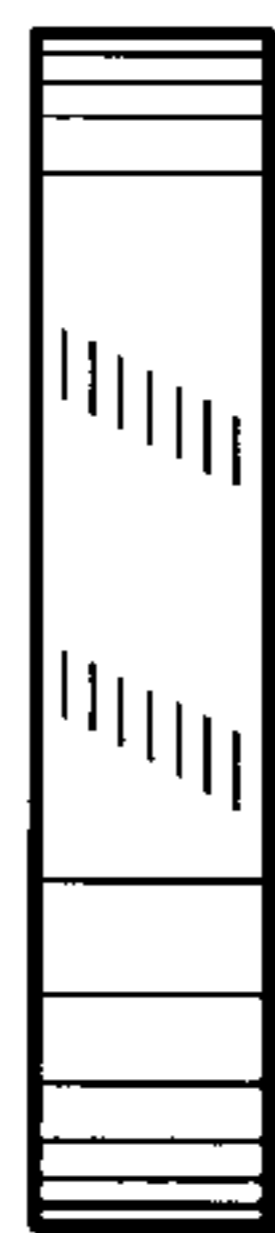

FIG. 4



FIG. 5



FIG. 6