



US00D523803S

(12) **United States Design Patent**
Smith et al.

(10) **Patent No.: US D523,803 S**
(45) **Date of Patent: ** Jun. 27, 2006**

(54) **VEHICLE BRAKE CONTROLLER BRACKET**

D513,171 S * 12/2005 Richardson D8/394

(75) Inventors: **Bruce E. Smith**, Leo, IN (US);
Mitchell Auerbach, Grand Haven, MI
(US); **Fred Brickley**, Battle Creek, MI
(US)

(73) Assignee: **Cequent Electric Products, Inc.**,
Tekonsha, MI (US)

(**) Term: **14 Years**

(21) Appl. No.: **29/215,960**

(22) Filed: **Oct. 27, 2004**

(51) **LOC (8) Cl.** **12-06**

(52) **U.S. Cl.** **D12/223**; D8/394

(58) **Field of Classification Search** D12/223;
D8/349, 354-356, 394-396, 373; 248/200,
248/300

See application file for complete search history.

(56) **References Cited**

U.S. PATENT DOCUMENTS

D433,387 S	11/2000	Roth et al.	
D434,011 S	11/2000	Roth et al.	
D434,391 S	11/2000	Roth et al.	
D435,494 S	12/2000	Reichard	
D451,611 S	* 12/2001	Pontarolo D25/119
D468,273 S	1/2003	Reichard	
D468,704 S	1/2003	Reichard	
D468,705 S	1/2003	Reichard	
D488,370 S	* 4/2004	Sivertsen D8/354
D509,959 S	* 9/2005	Nykoluk D3/289

OTHER PUBLICATIONS

MOTOROLA, Motorola Holster—SYN0718, http://commerce.motorola.com/cgi-bin/ncommerce3/ProductDisplay?prfnbr=230044&prmenbr=126&accessories_cgfnbr=22...

* cited by examiner

Primary Examiner—Melody N. Brown

(74) *Attorney, Agent, or Firm*—Robert Earp; Todd Benni; McDonald Hopkins Co., LPX

(57) **CLAIM**

The ornamental design for a vehicle brake controller bracket, as shown and described.

DESCRIPTION

FIG. 1 is a perspective view as seen from the top, front, and left side of the vehicle brake controller bracket showing our new design;

FIG. 2 is a top plan view thereof;

FIG. 3 is a bottom plan view thereof;

FIG. 4 is a right side elevational view thereof, the left side elevational view thereof being a mirror image of the right side elevational view;

FIG. 5 is a front elevational view thereof; and,

FIG. 6 is a rear elevational view thereof.

The broken lines are shown throughout the drawing for illustrative purposes only and form no part of the claimed design.

1 Claim, 3 Drawing Sheets

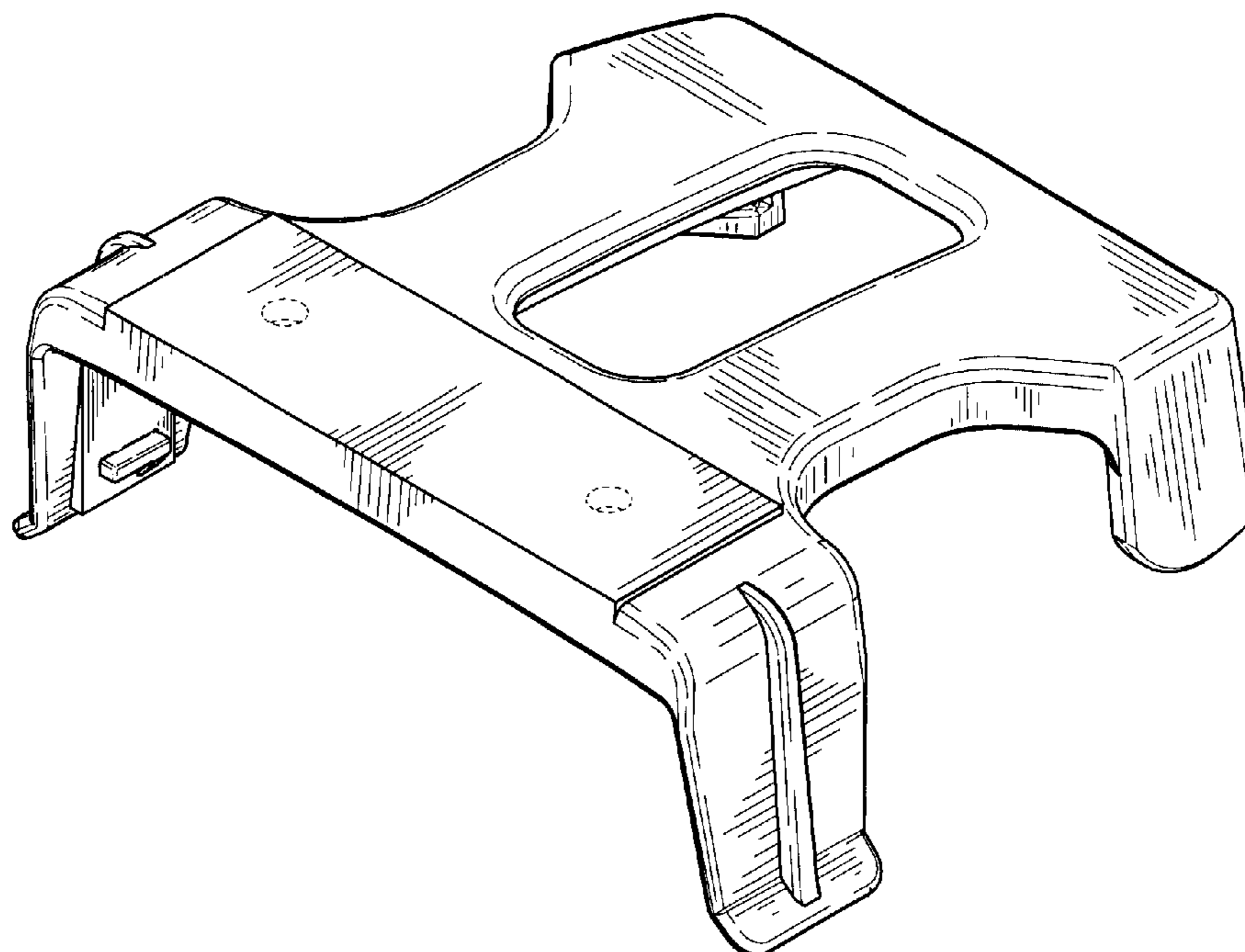

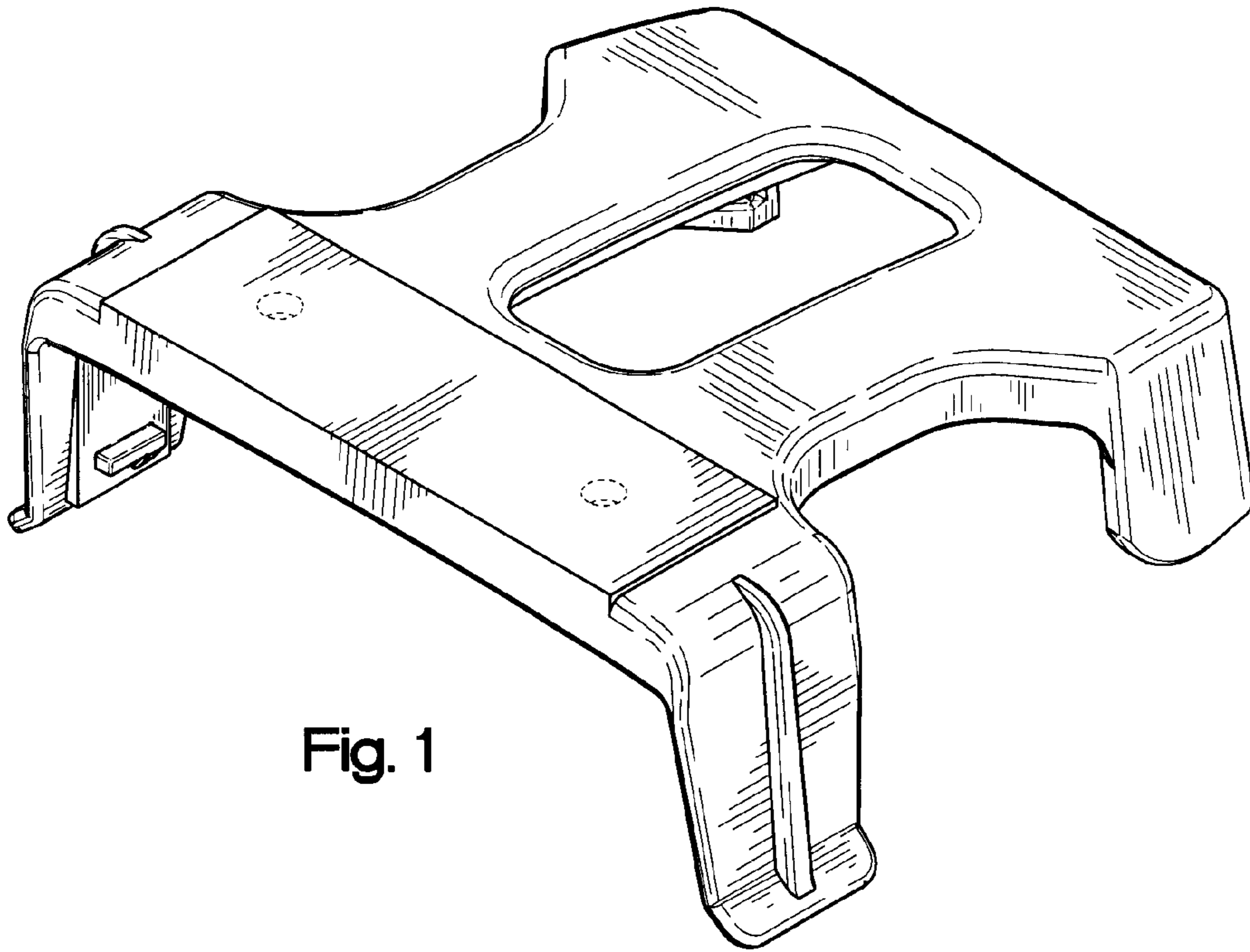

Fig. 1

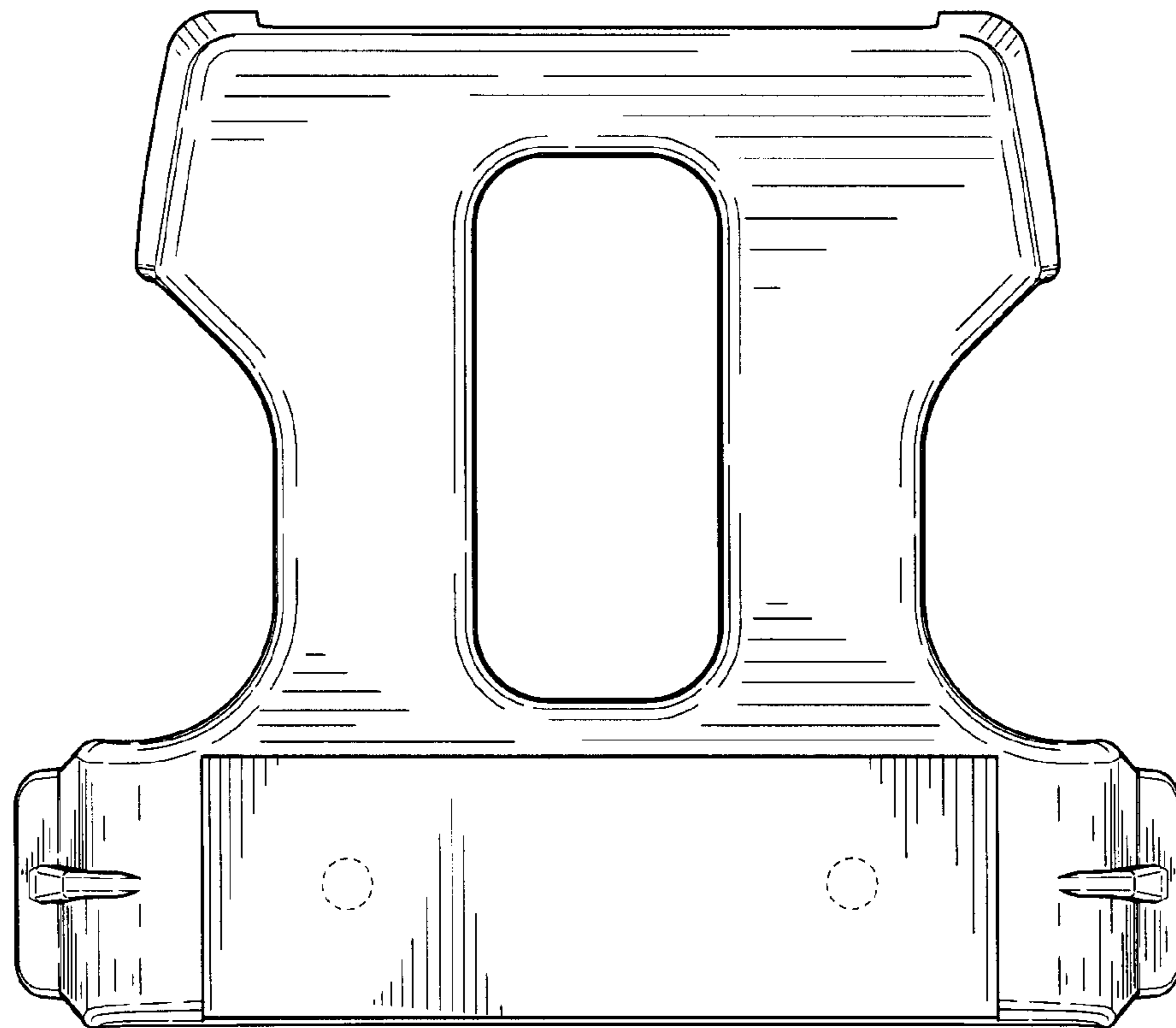

Fig. 2

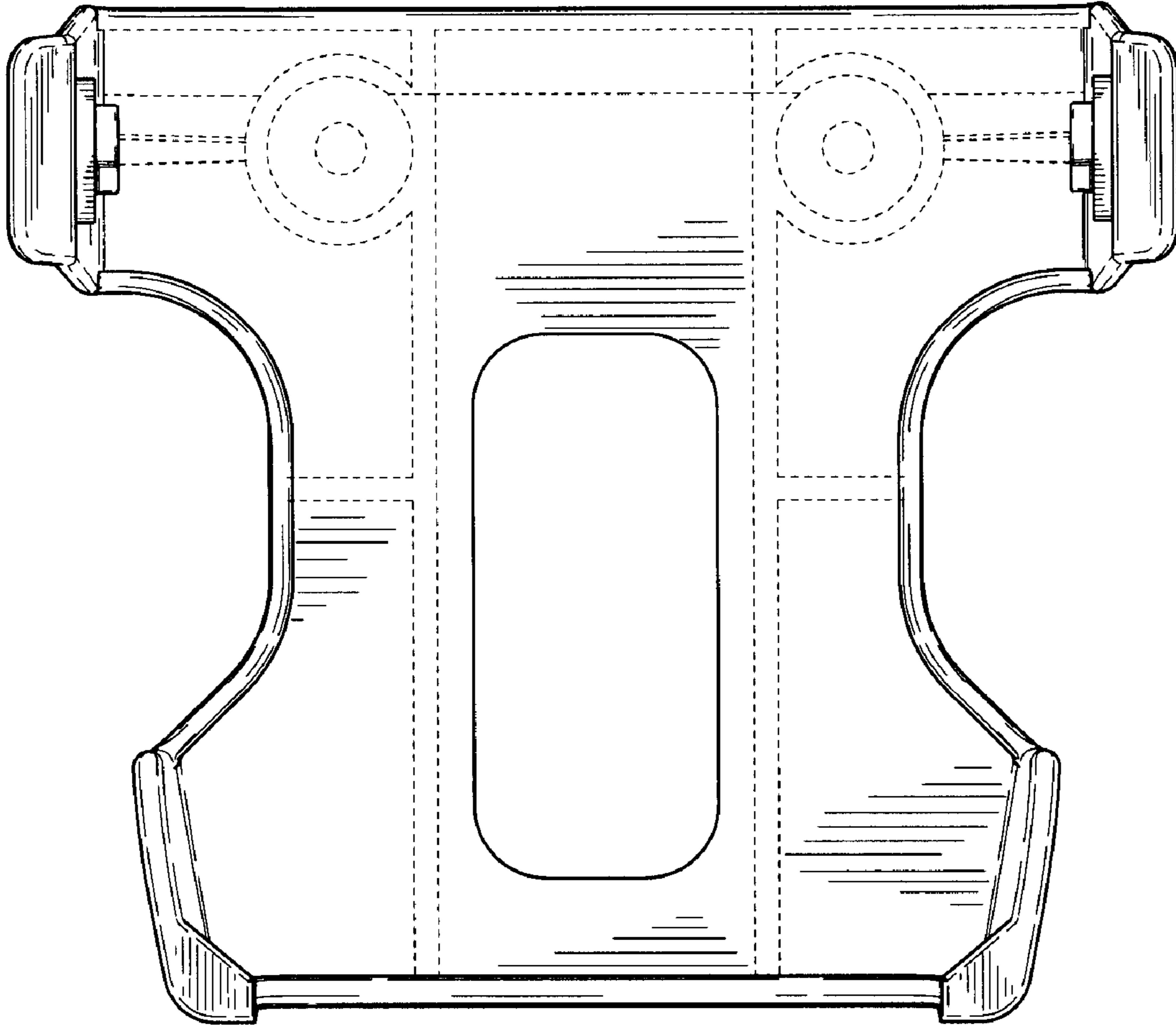

Fig. 3

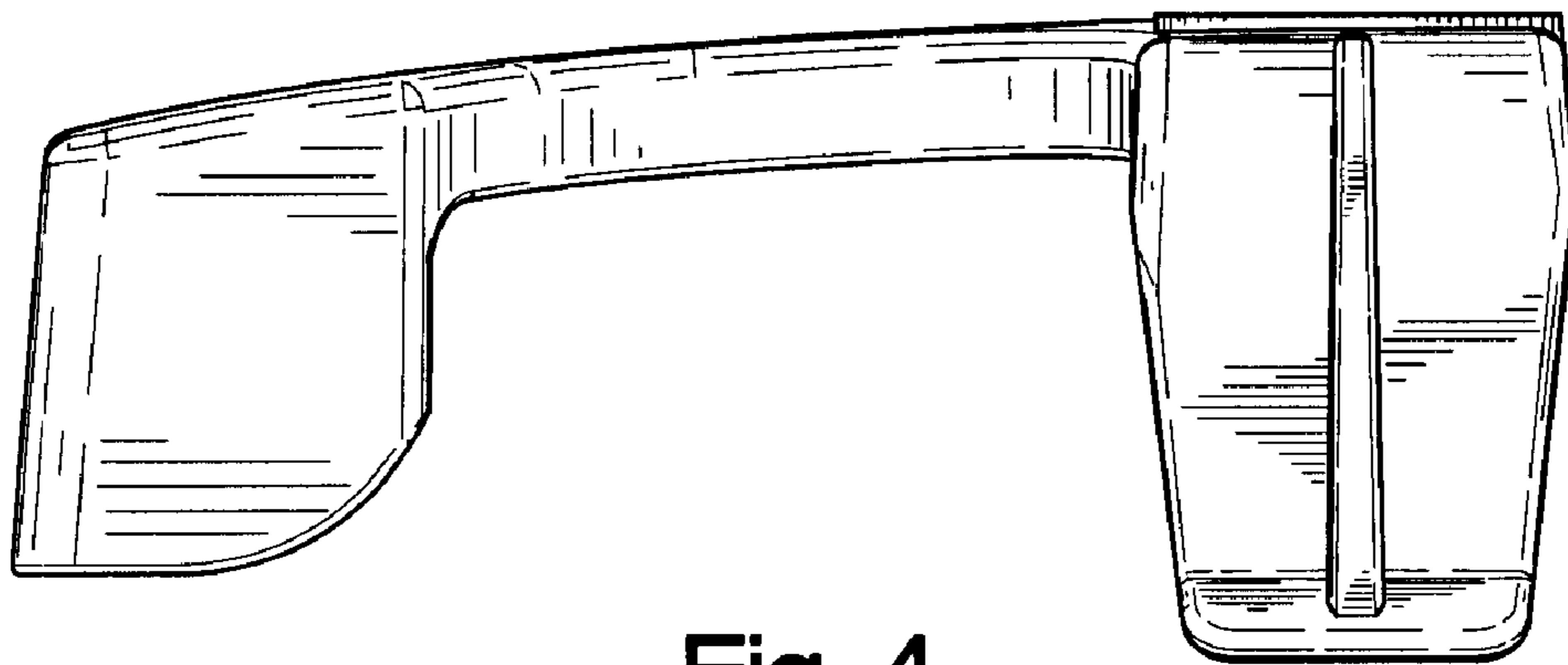

Fig. 4

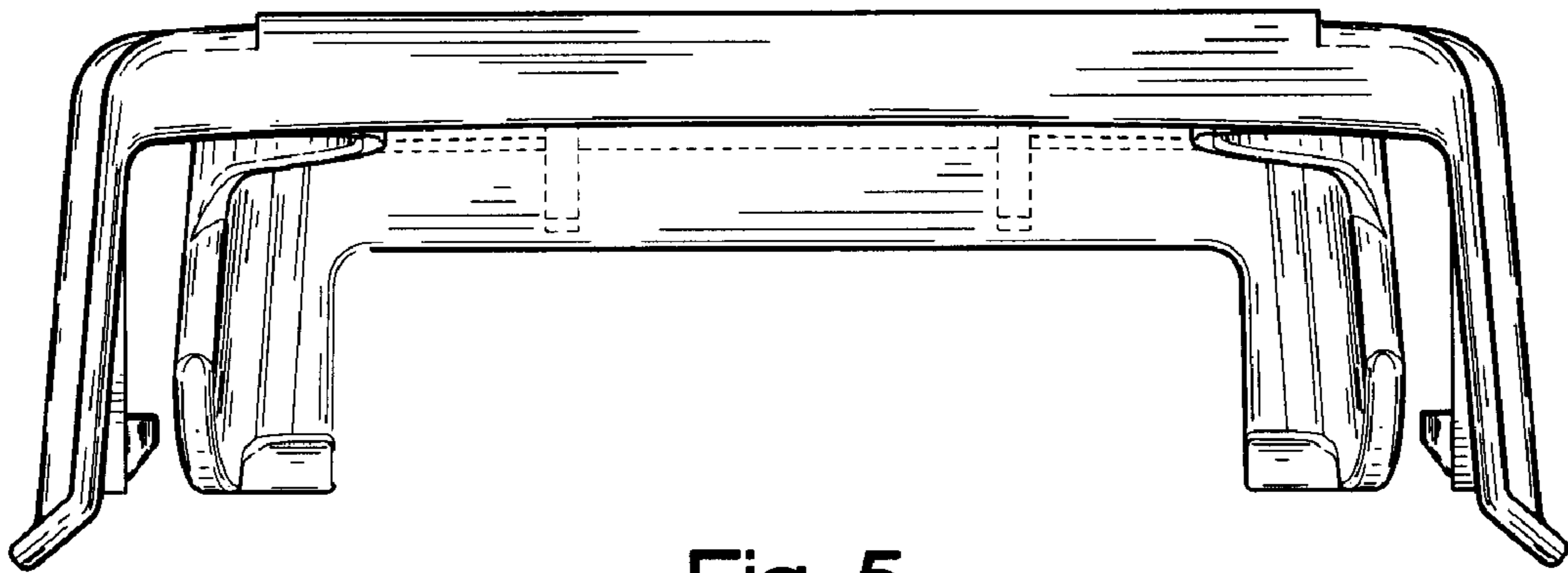

Fig. 5

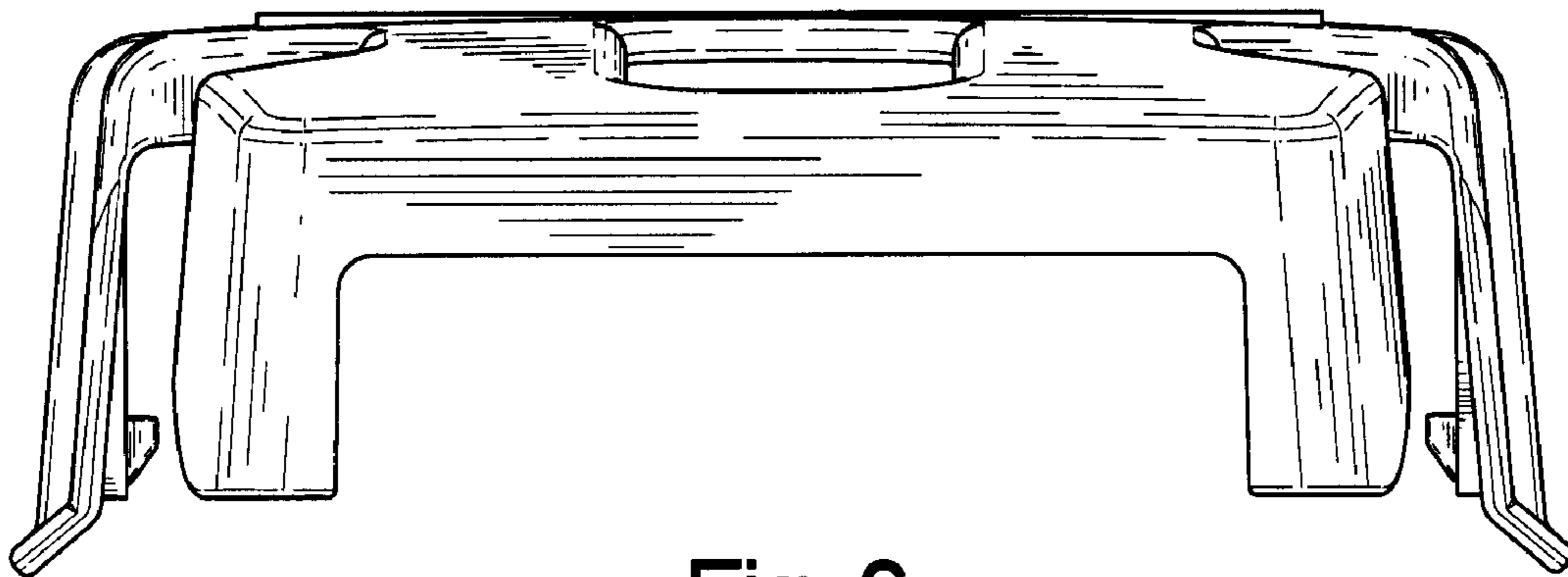

Fig. 6