



US00D523379S

(12) **United States Design Patent**
Brown et al.

(10) **Patent No.:** **US D523,379 S**
(45) **Date of Patent:** **** Jun. 20, 2006**

(54) **MOTORCYCLE FRAME**

D494,107 S * 8/2004 Lin D12/110
D498,708 S 11/2004 James D12/110

(75) Inventors: **Duane Brown**, Ravensdale, WA (US);
Chris Brown, Auburn, WA (US); **Kurt Hall**, Olympia, WA (US)

* cited by examiner

(73) Assignee: **BBR Motorsports, Inc.**, Auburn, WA (US)

Primary Examiner—Alan P. Douglas
Assistant Examiner—Linda Brooks
(74) *Attorney, Agent, or Firm*—Seed IP Law Group PLLC

(**) Term: **14 Years**

(57) **CLAIM**

(21) Appl. No.: **29/224,602**

The ornamental design for a motorcycle frame, as shown and described.

(22) Filed: **Mar. 2, 2005**

DESCRIPTION

(51) **LOC (8) Cl.** **12-11**

(52) **U.S. Cl.** **D12/110**

(58) **Field of Classification Search** D12/110,
D12/117; 180/219, 311, 312; 280/281.1,
280/288.1–288.3

FIG. 1 is an isometric projection of a top side view of a motorcycle frame showing our new design;
FIG. 2 is a top plan view thereof;
FIG. 3 is an elevational front view thereof;
FIG. 4 is an elevational rear thereof;
FIG. 5 is an elevational view of a first side thereof;
FIG. 6 is an elevational view of a second side thereof; and,
FIG. 7 is a bottom plan view thereof.

See application file for complete search history.

(56) **References Cited**

U.S. PATENT DOCUMENTS

D212,404 S * 10/1968 Bauer et al. D12/110

1 Claim, 7 Drawing Sheets

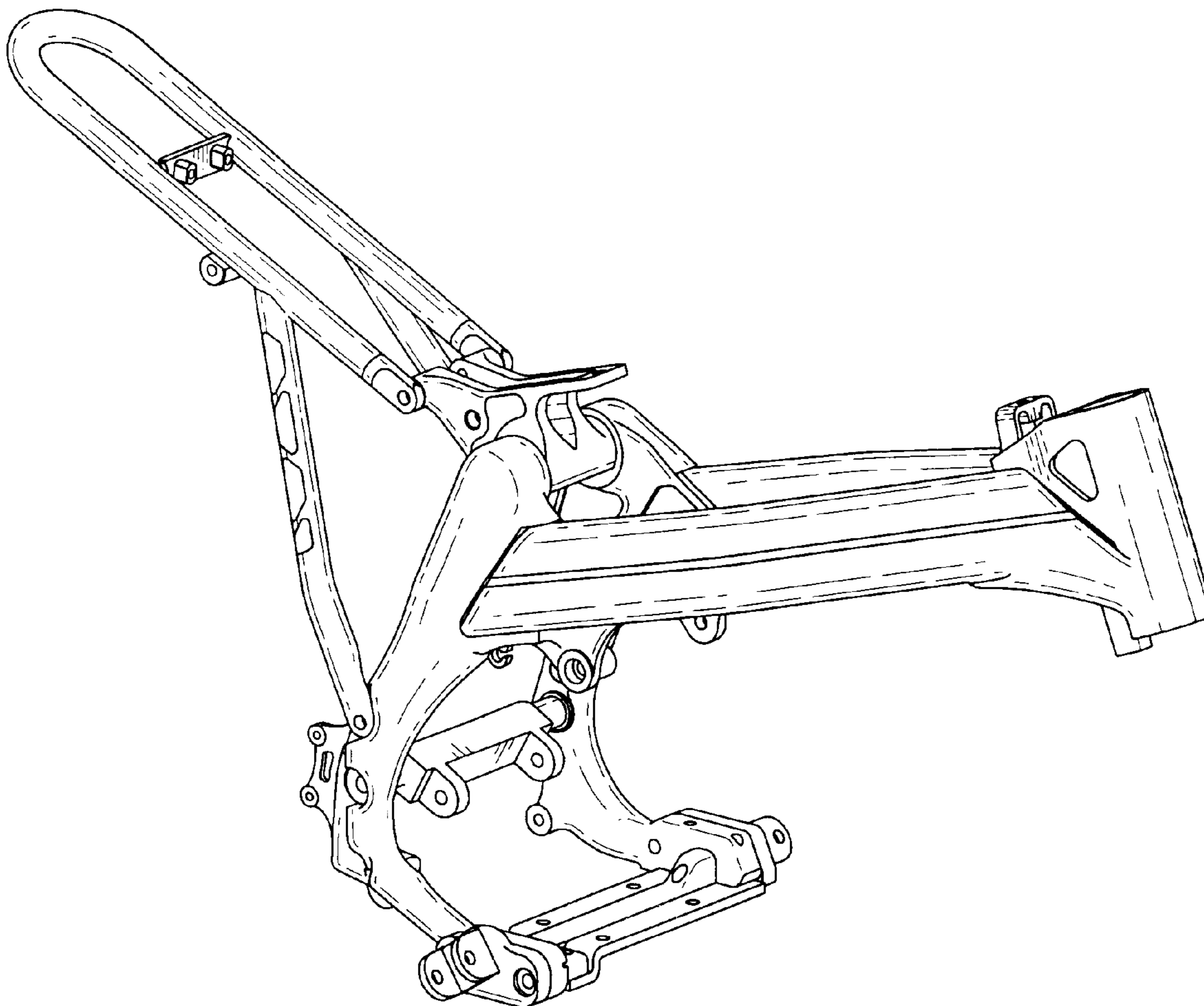

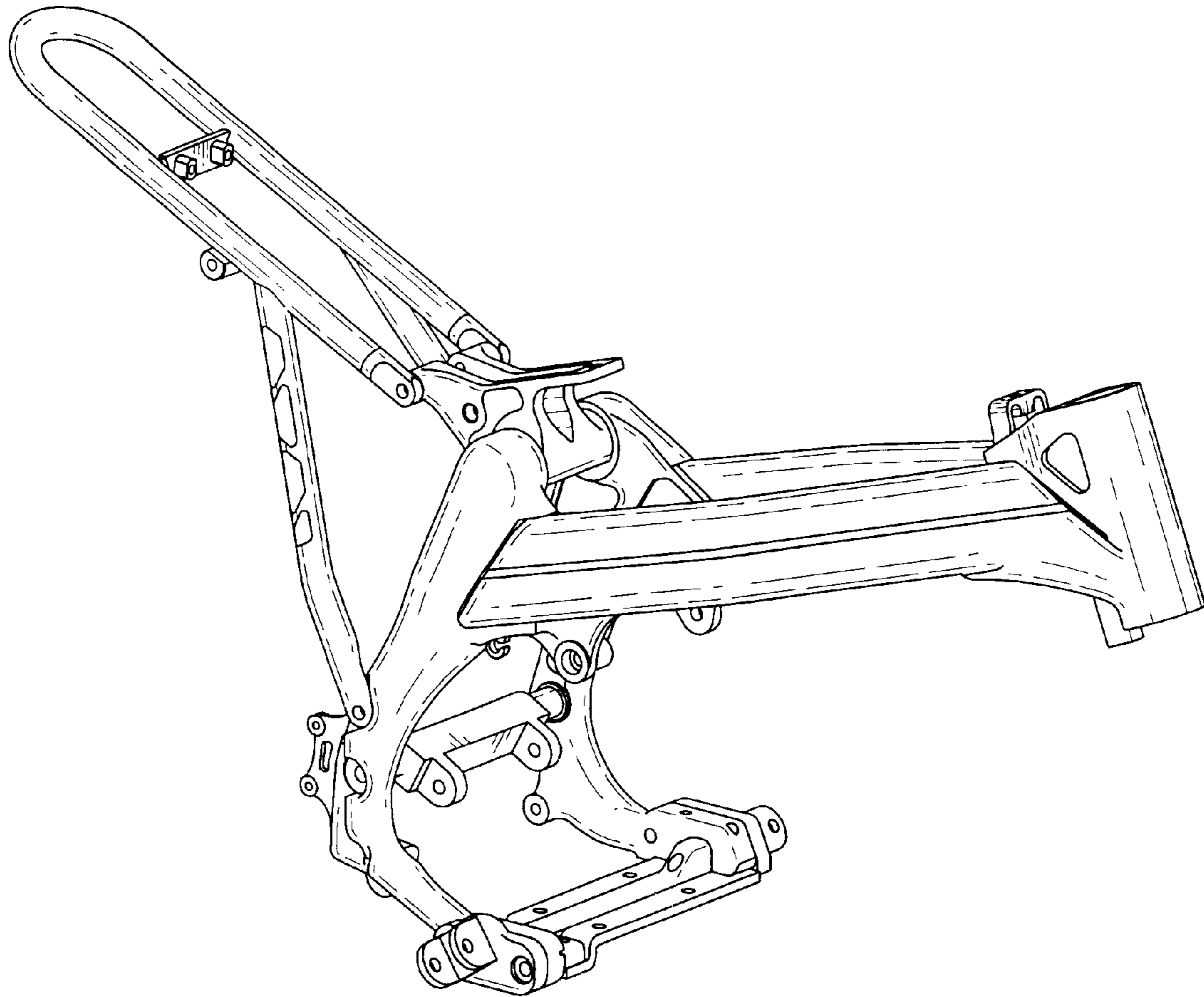

FIG. 1

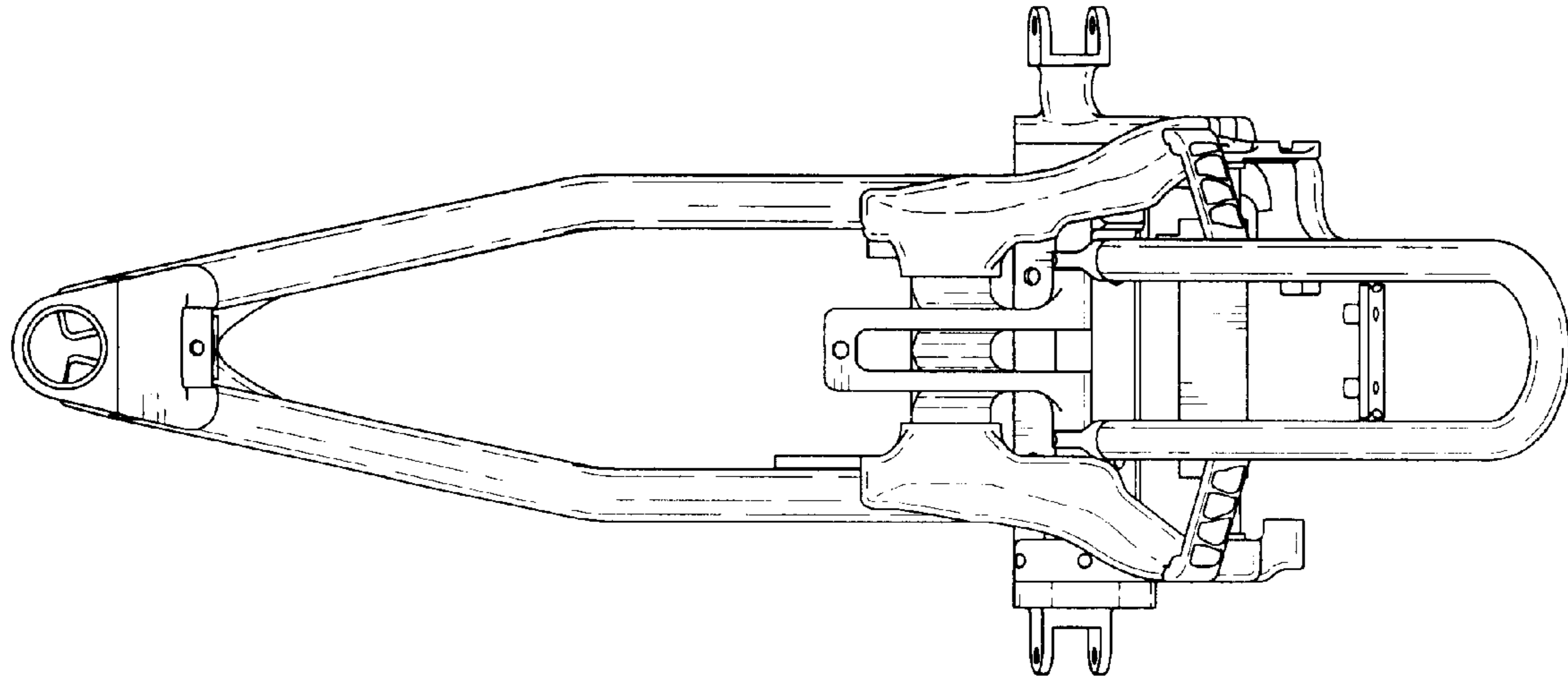

FIG. 2

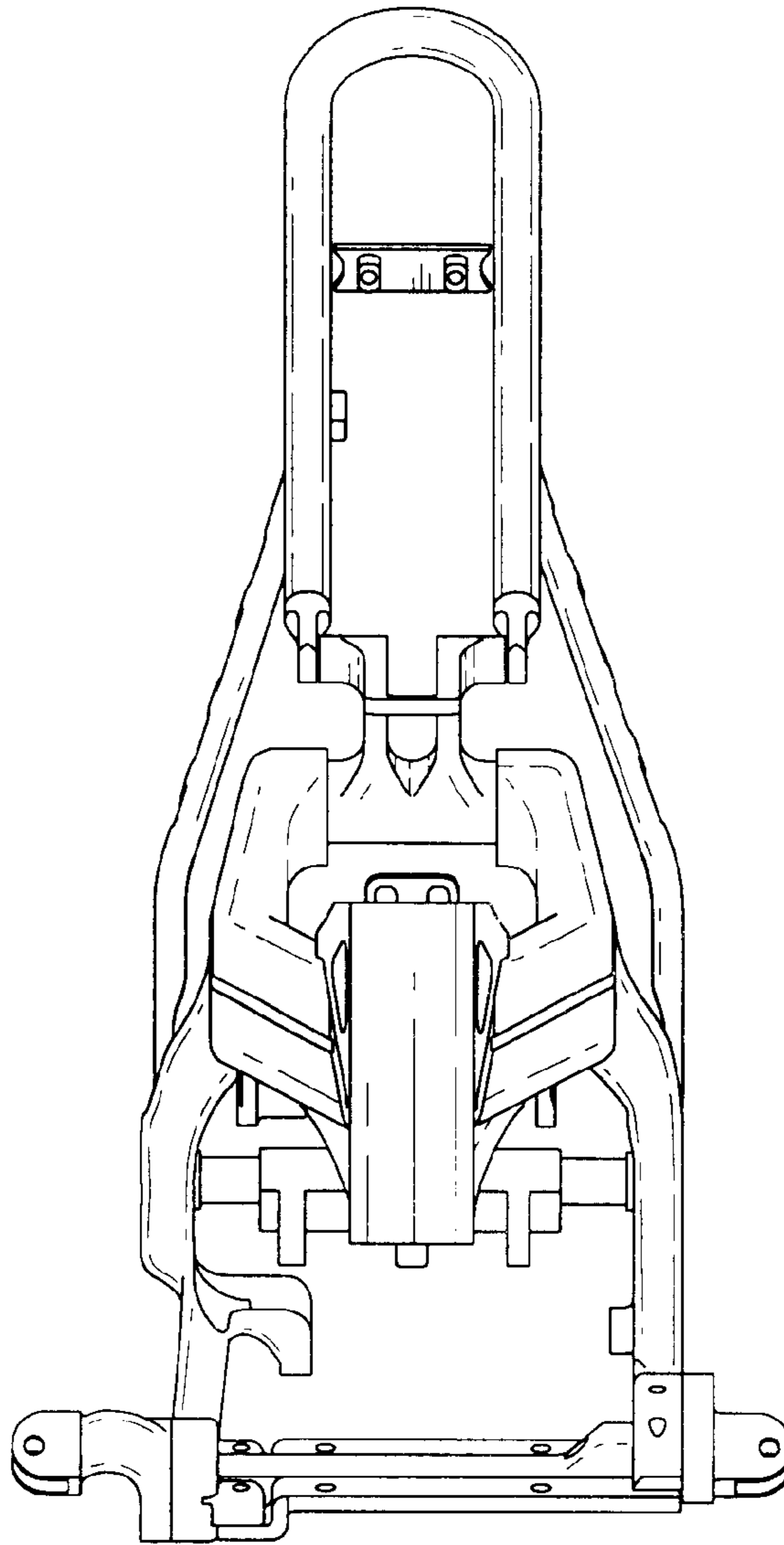

FIG. 3

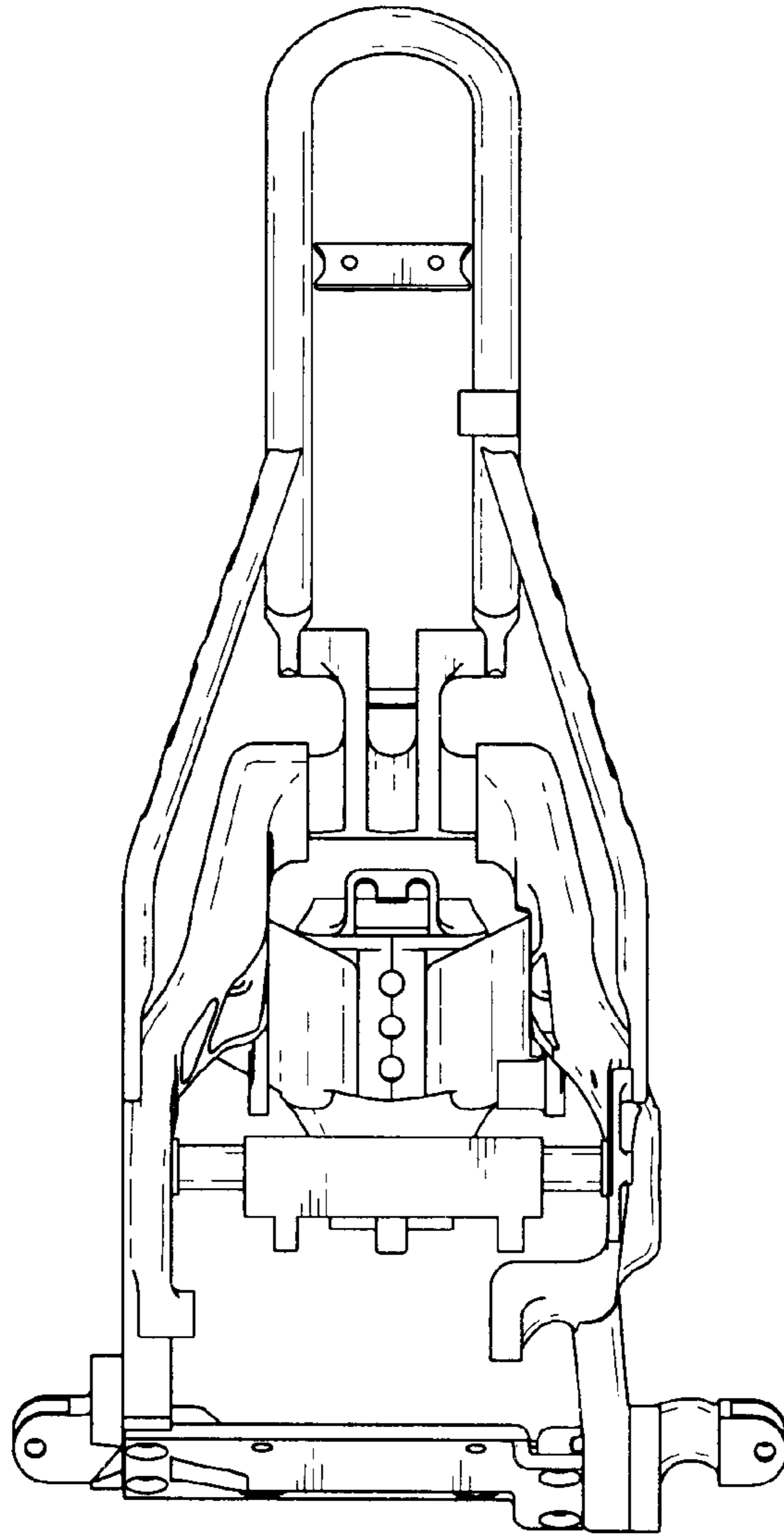

FIG. 4

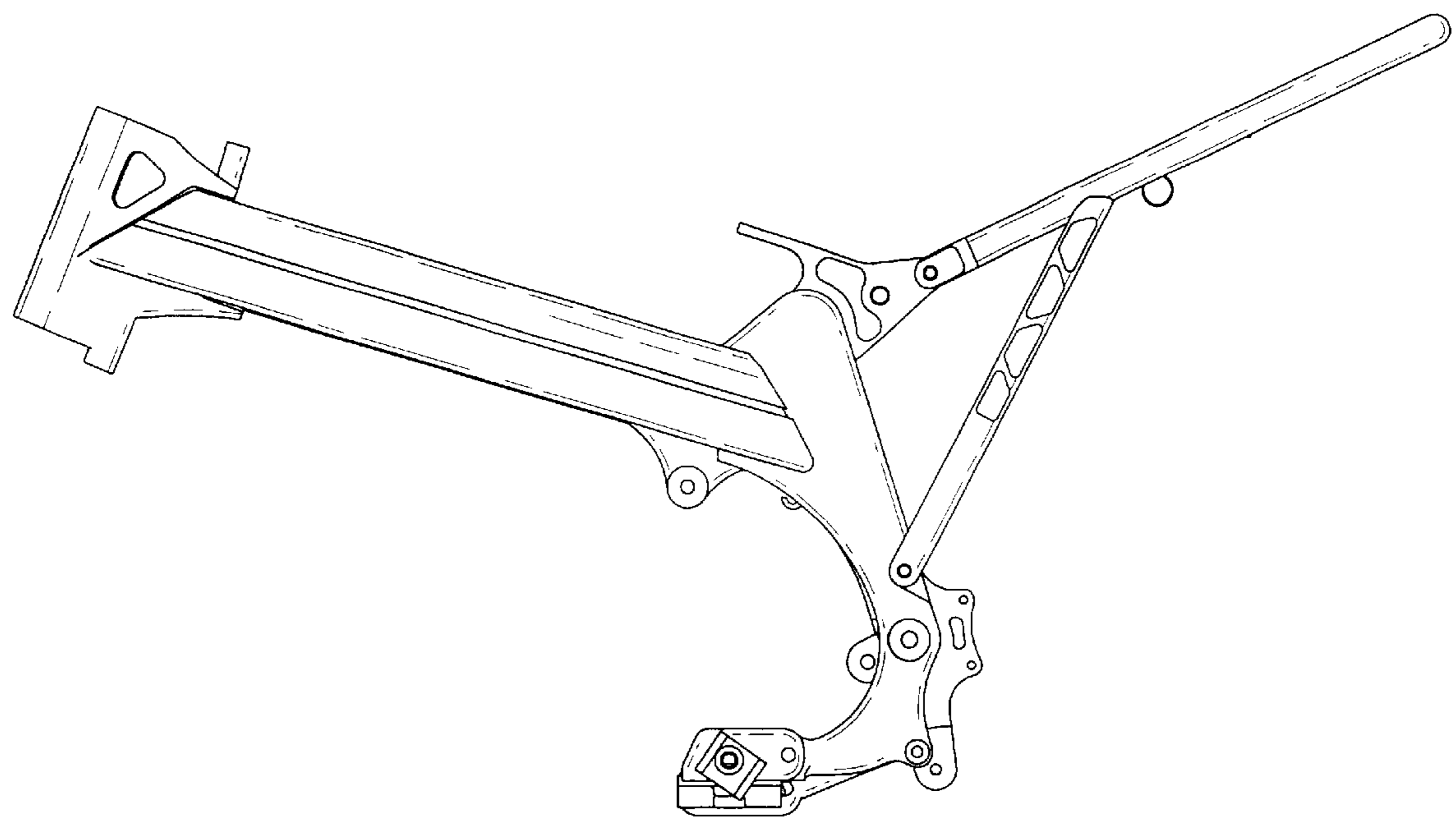

FIG. 5

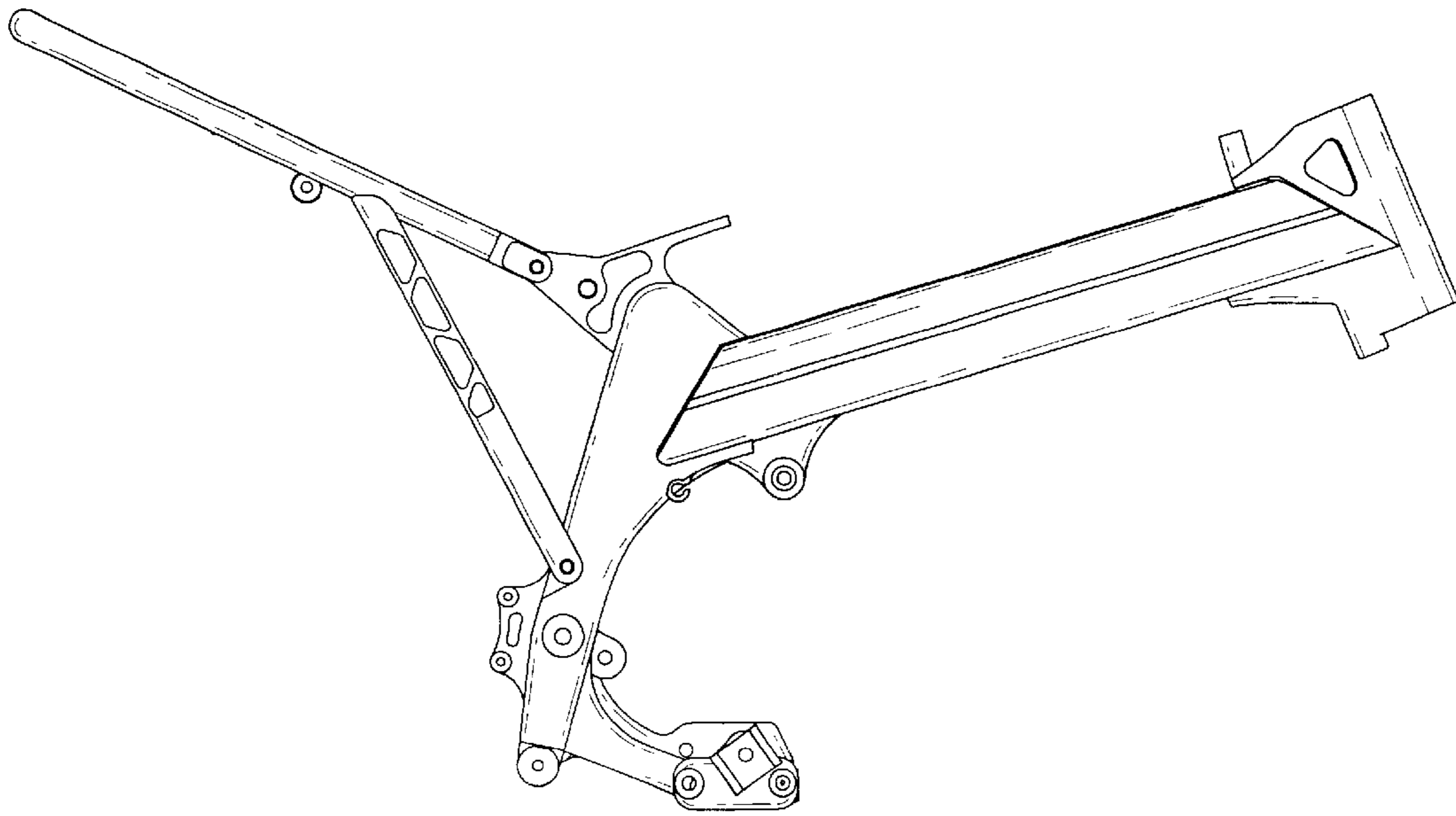

FIG. 6

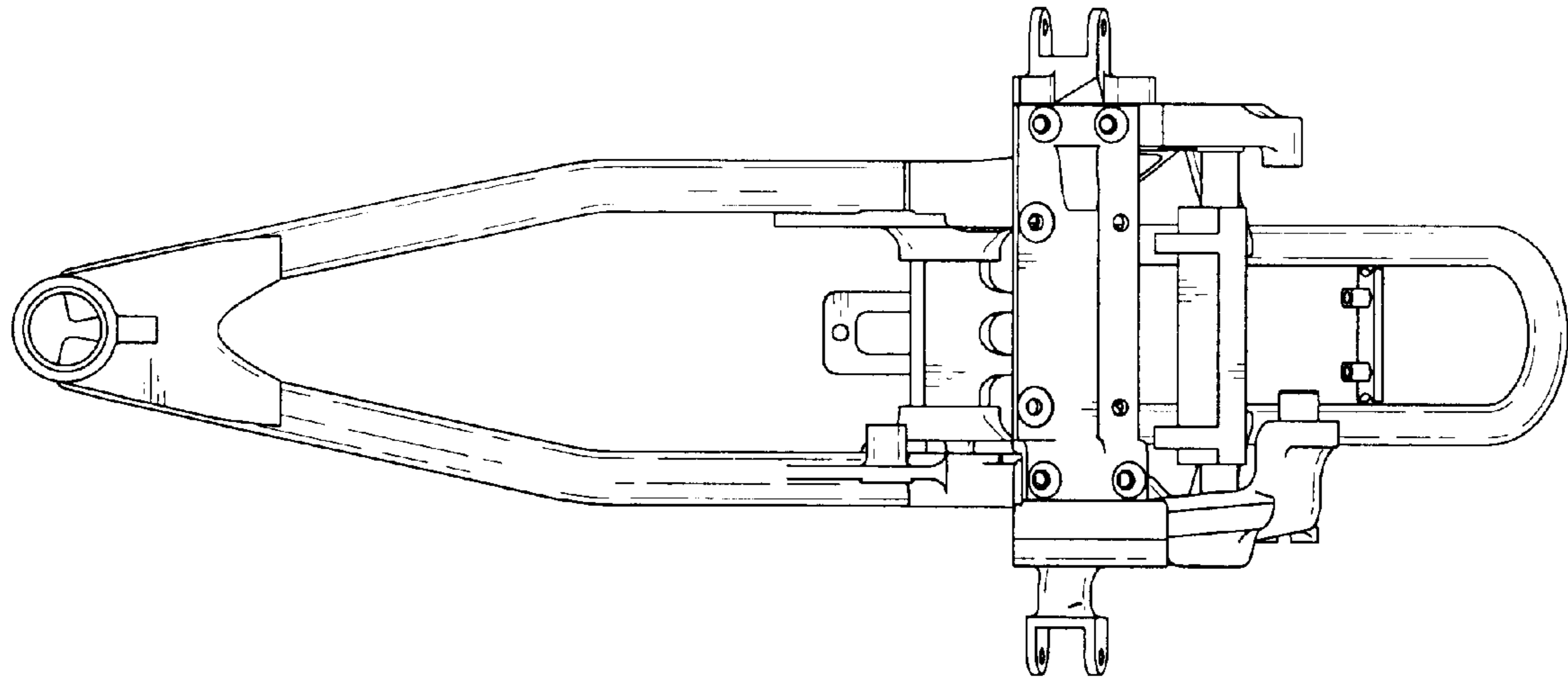

FIG. 7