



US00D522955S

(12) **United States Design Patent**  
**Agrillo**

(10) **Patent No.:** **US D522,955 S**  
(45) **Date of Patent:** **\*\* Jun. 13, 2006**

(54) **LIFTING FIXTURE FOR AN AIRCRAFT**

(74) *Attorney, Agent, or Firm*—Joseph A. Agrillo

(75) Inventor: **Joseph A. Agrillo**, 730 S. Federal Hwy., Stuart, FL (US) 34994

(57) **CLAIM**

I claim the ornamental design for a lifting fixture for an aircraft, as shown and described.

(73) Assignee: **Joseph A. Agrillo**, Stuart, FL (US)

(\*\*) Term: **14 Years**

**DESCRIPTION**

(21) Appl. No.: **29/196,250**

FIG. 1 is a perspective view of the present invention showing a landing gear cup in the foreground and a jack attachment cylinder in the rear with cap on top of cylinder. FIG. 2 is perspective view of the present invention showing the jack attachment cylinder in the foreground and the landing gear cup in the rear.

(22) Filed: **Dec. 24, 2003**

(51) **LOC (8) Cl.** ..... **12-12**

(52) **U.S. Cl.** ..... **D12/345**

(58) **Field of Classification Search** ..... D12/319, D12/345; 244/137.3, 118.1, 137.4  
See application file for complete search history.

FIG. 3 is a plan view of the present invention; and, FIG. 4 is a perspective view of the present invention as used to lift an aircraft landing gear, with a jack in dotted lines in the foreground connected to the attachment cylinder and the cup supporting an aircraft landing gear, also shown in dotted lines.

(56) **References Cited**

**U.S. PATENT DOCUMENTS**

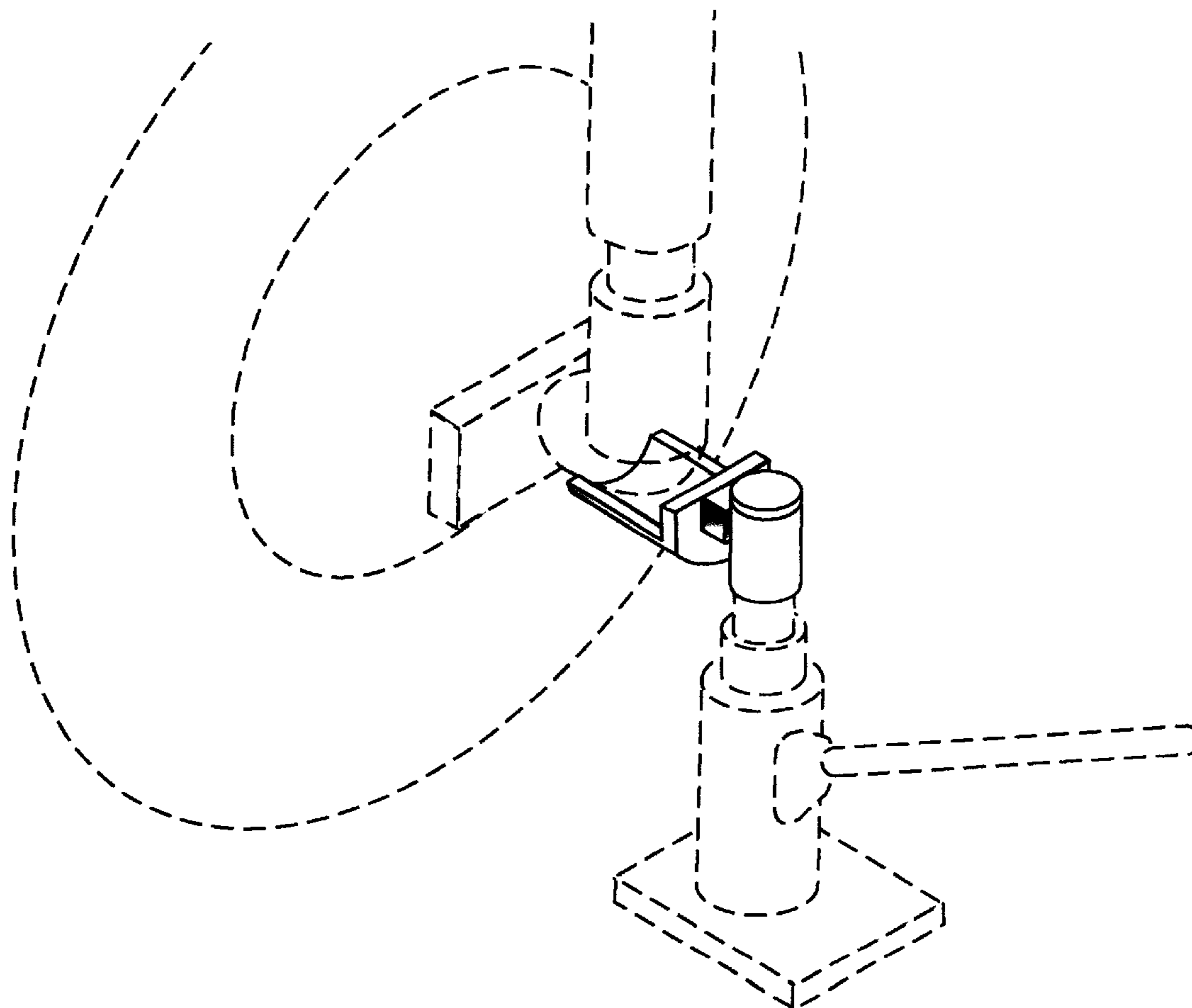
D363,915 S \* 11/1995 Weems ..... D12/345

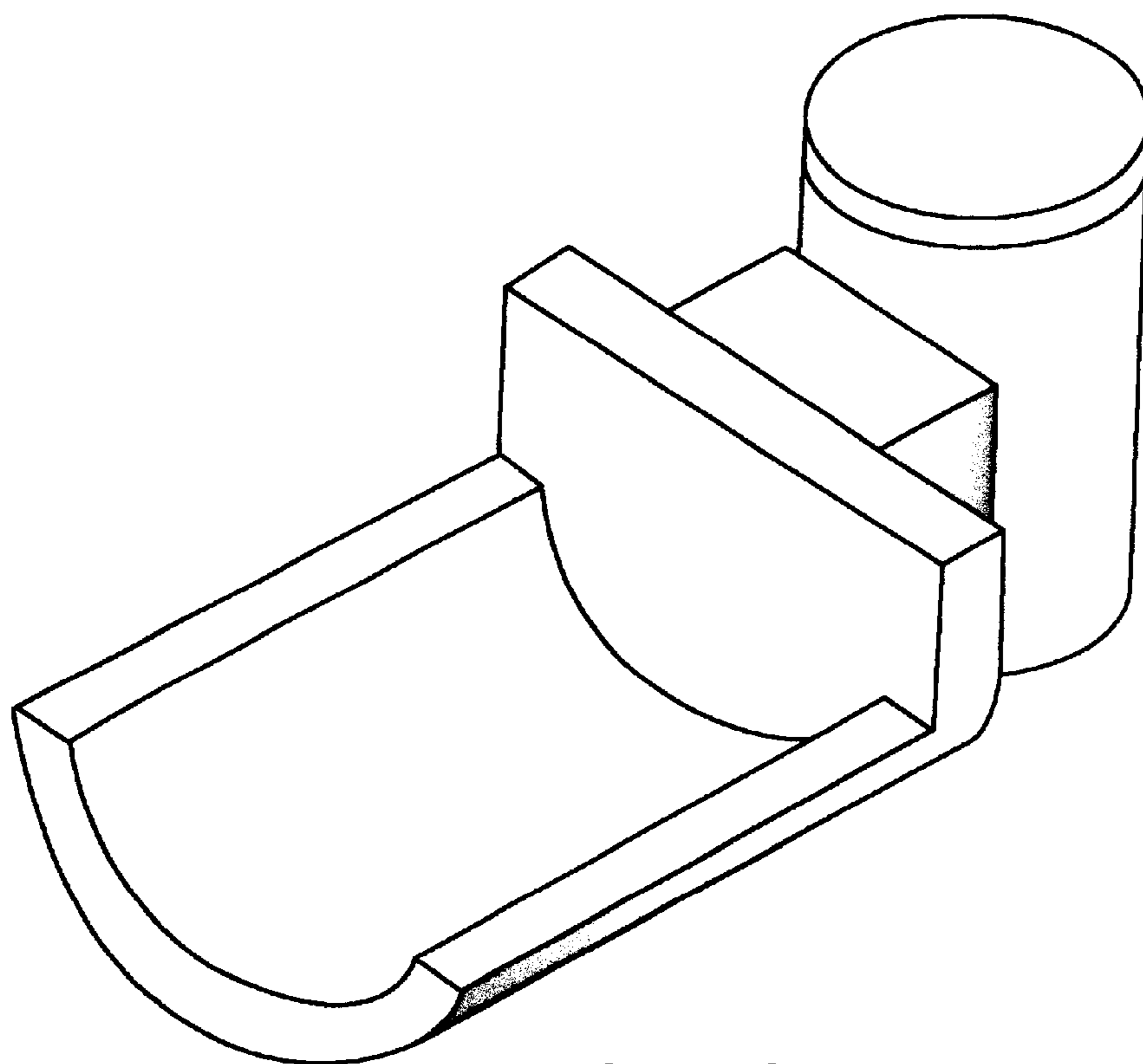
The broken line showing of the portions of the aircraft is for illustrative purposes only and forms no part of the claimed design.

\* cited by examiner

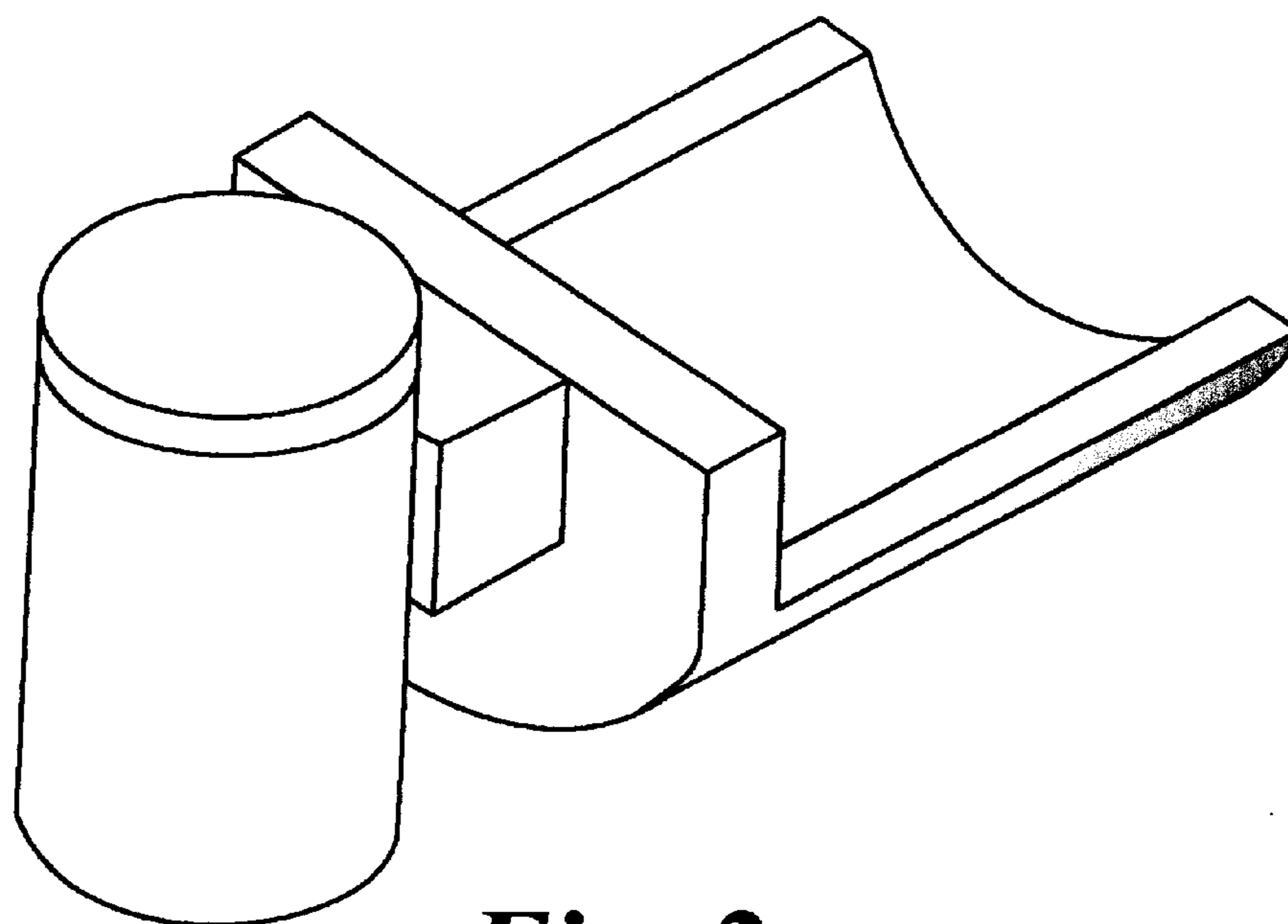
*Primary Examiner*—Marcus A. Jackson

**1 Claim, 2 Drawing Sheets**

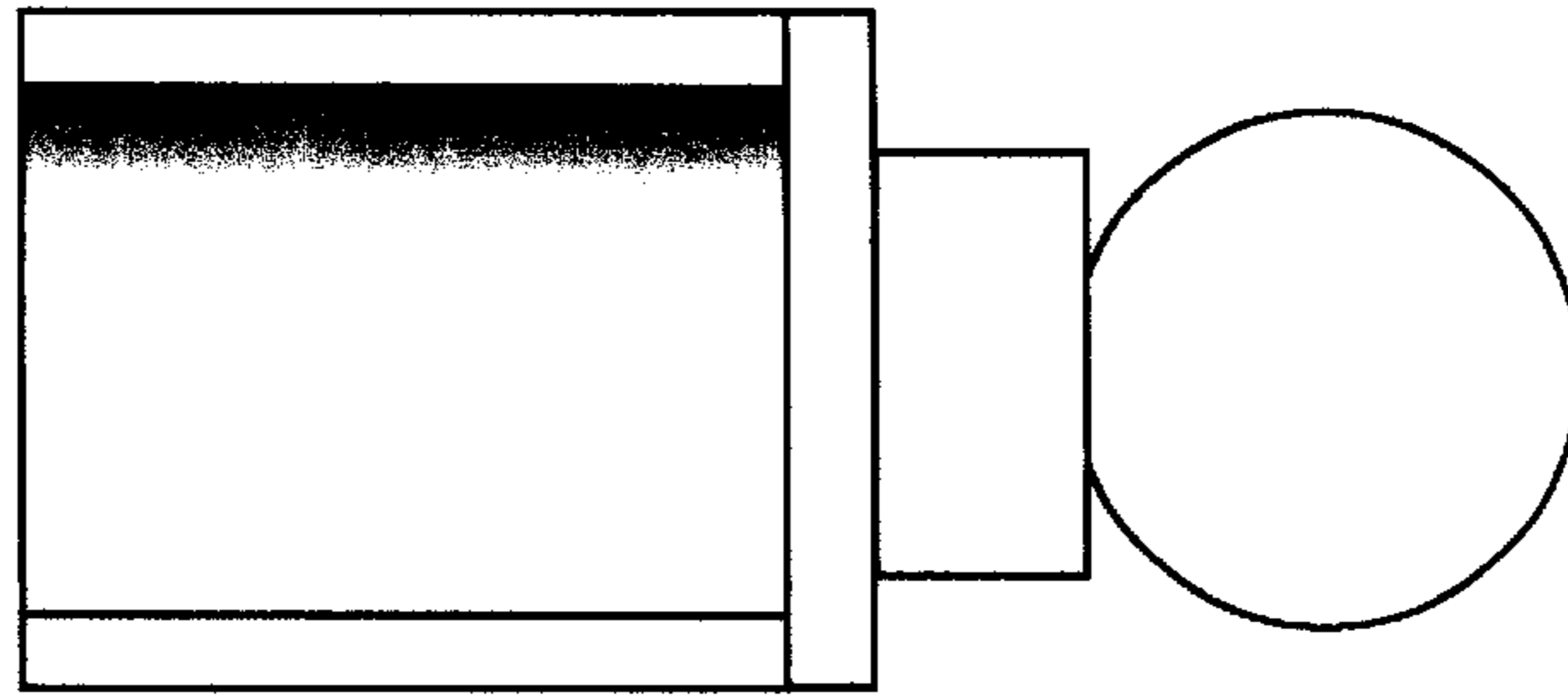




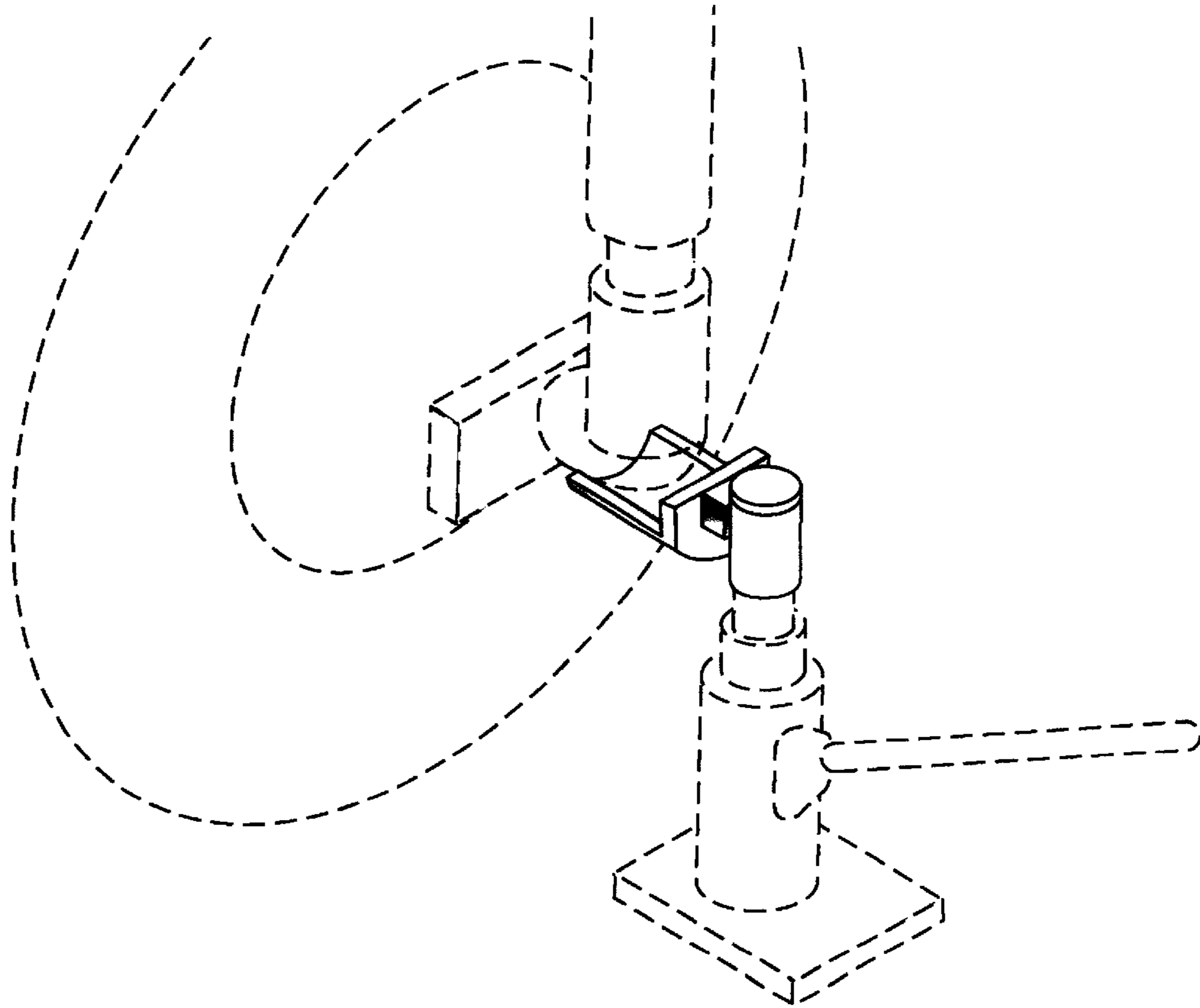
*Fig. 1*



*Fig. 2*



***Fig. 3***



***Fig. 4***