



US00D522925S

(12) **United States Design Patent**  
**Nishino**

(10) **Patent No.:** **US D522,925 S**  
(45) **Date of Patent:** **\*\* Jun. 13, 2006**

(54) **MOTORCYCLE**

D470,799 S \* 2/2003 Yamaguchi et al. .... D12/110

(75) Inventor: **Toshiyuki Nishino**, Hamamatsu (JP)

\* cited by examiner

(73) Assignee: **Suzuki Motor Corporation** (JP)

*Primary Examiner*—Alan P. Douglas

*Assistant Examiner*—Linda Brooks

(\*\*) Term: **14 Years**

(74) *Attorney, Agent, or Firm*—Foley Hoag LLP

(21) Appl. No.: **29/213,511**

(57) **CLAIM**

(22) Filed: **Sep. 17, 2004**

The ornamental design for a motorcycle, as shown and described.

(30) **Foreign Application Priority Data**

**DESCRIPTION**

Mar. 18, 2004 (JP) ..... 2004-008279

(51) **LOC (8) Cl.** ..... **12-11**

FIG. 1 is a front perspective view of the right side of an motorcycle showing my new design;

FIG. 2 is a front perspective view of the left side thereof;

FIG. 3 is a rear perspective view of the right side thereof;

FIG. 4 is a rear perspective view of the left side thereof;

FIG. 5 is a top view thereof;

FIG. 6 is a bottom view thereof;

FIG. 7 is a right side elevational view thereof;

FIG. 8 is a left side elevational view thereof;

FIG. 9 is a front view thereof; and,

FIG. 10 is a rear view thereof.

The broken lines shown are for illustrative purposes only and form no part of the claimed design.

(52) **U.S. Cl.** ..... **D12/110**

(58) **Field of Classification Search** ..... D12/110;  
180/219

See application file for complete search history.

(56) **References Cited**

**U.S. PATENT DOCUMENTS**

D395,621 S \* 6/1998 Nishino ..... D12/110

D447,722 S \* 9/2001 Ito et al. .... D12/110

**1 Claim, 10 Drawing Sheets**

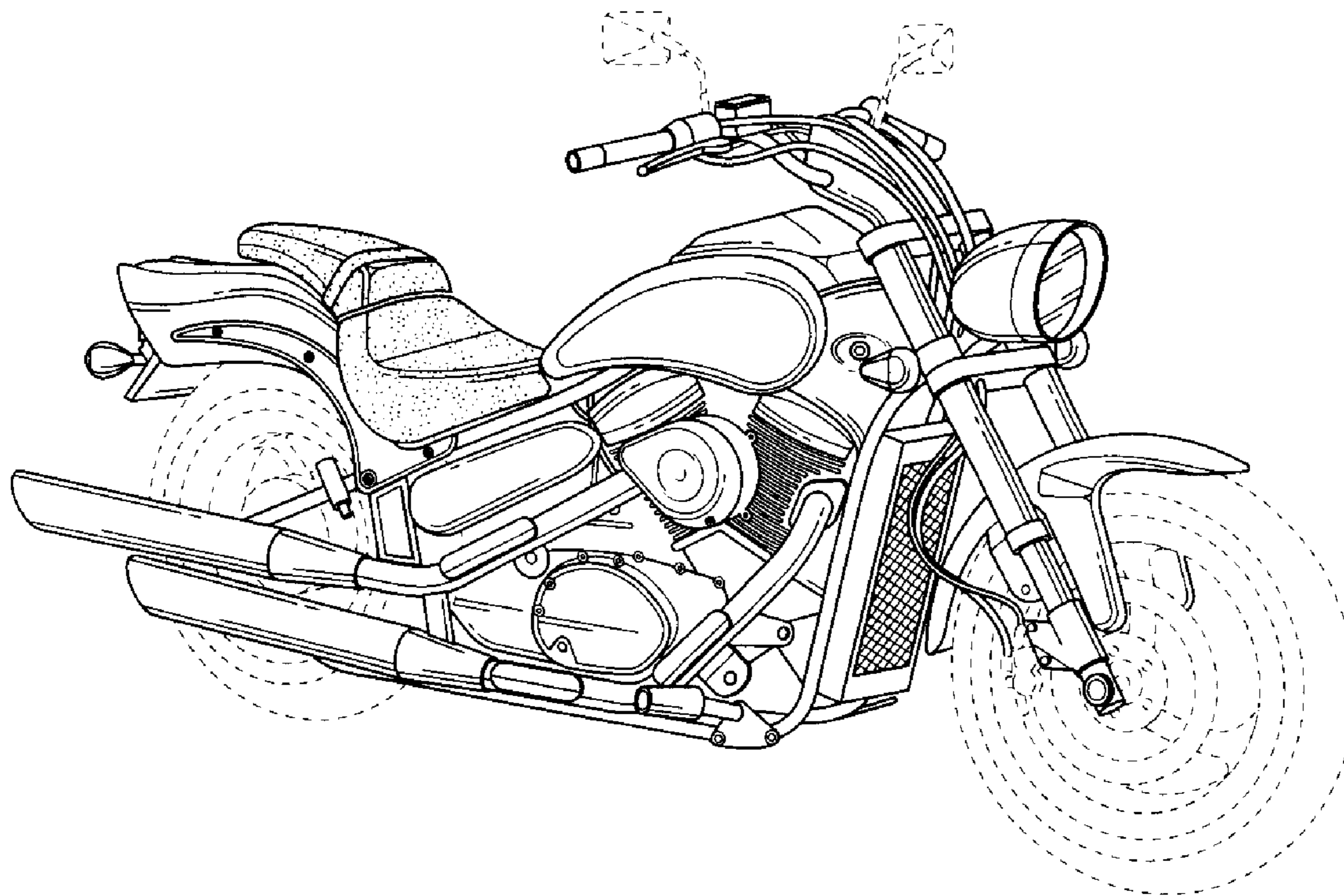

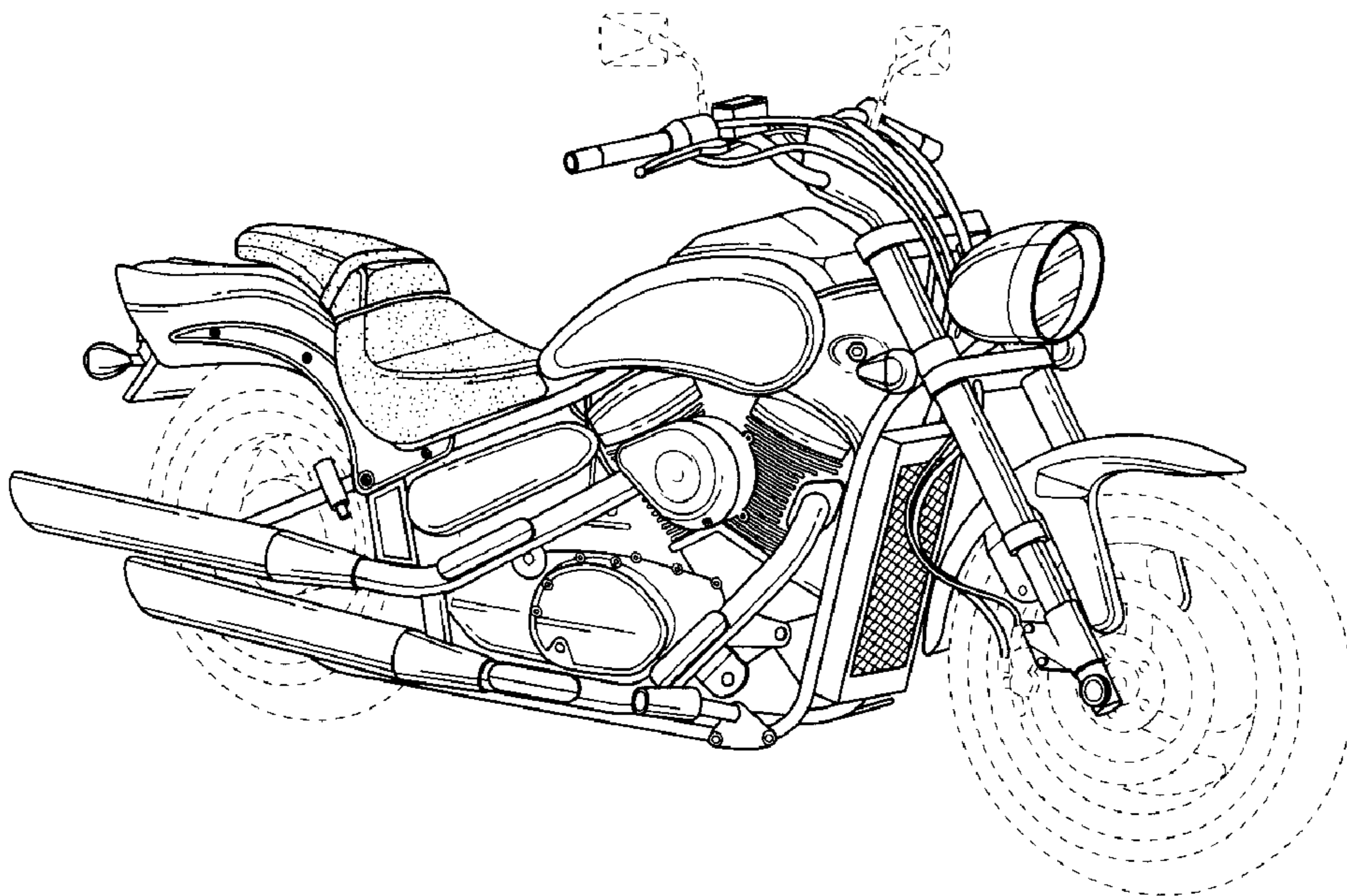

Fig. 1

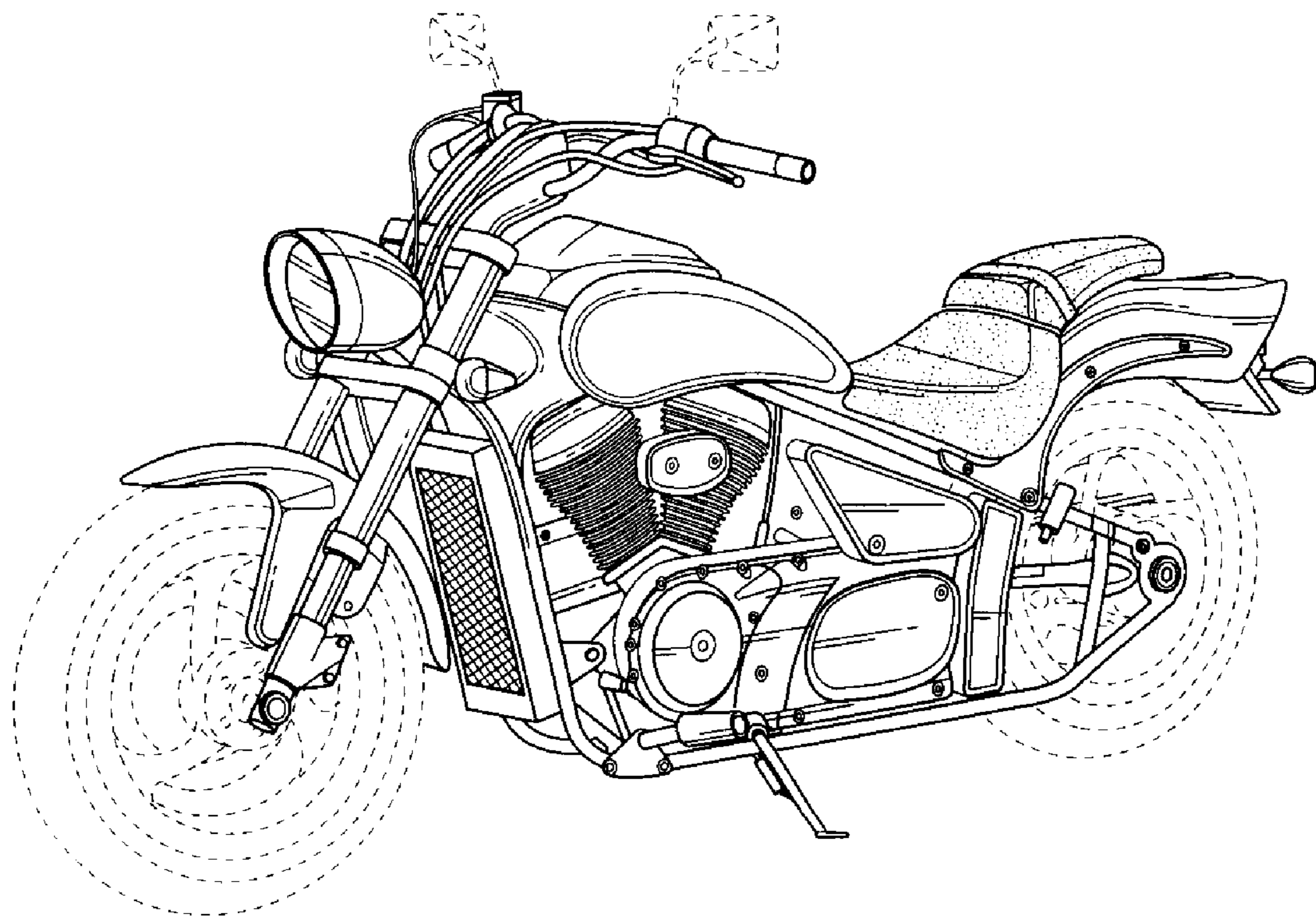

Fig. 2

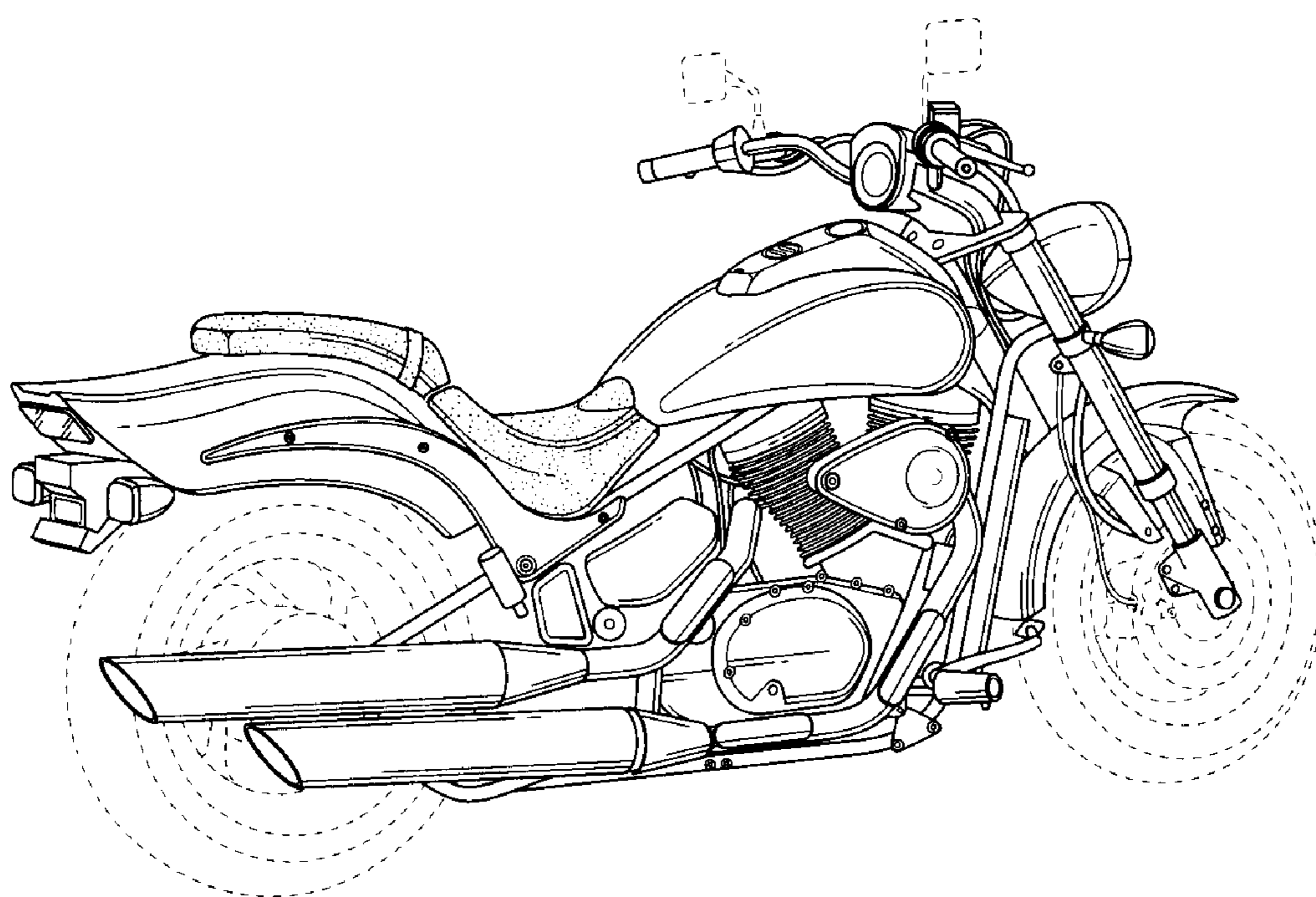

Fig. 3

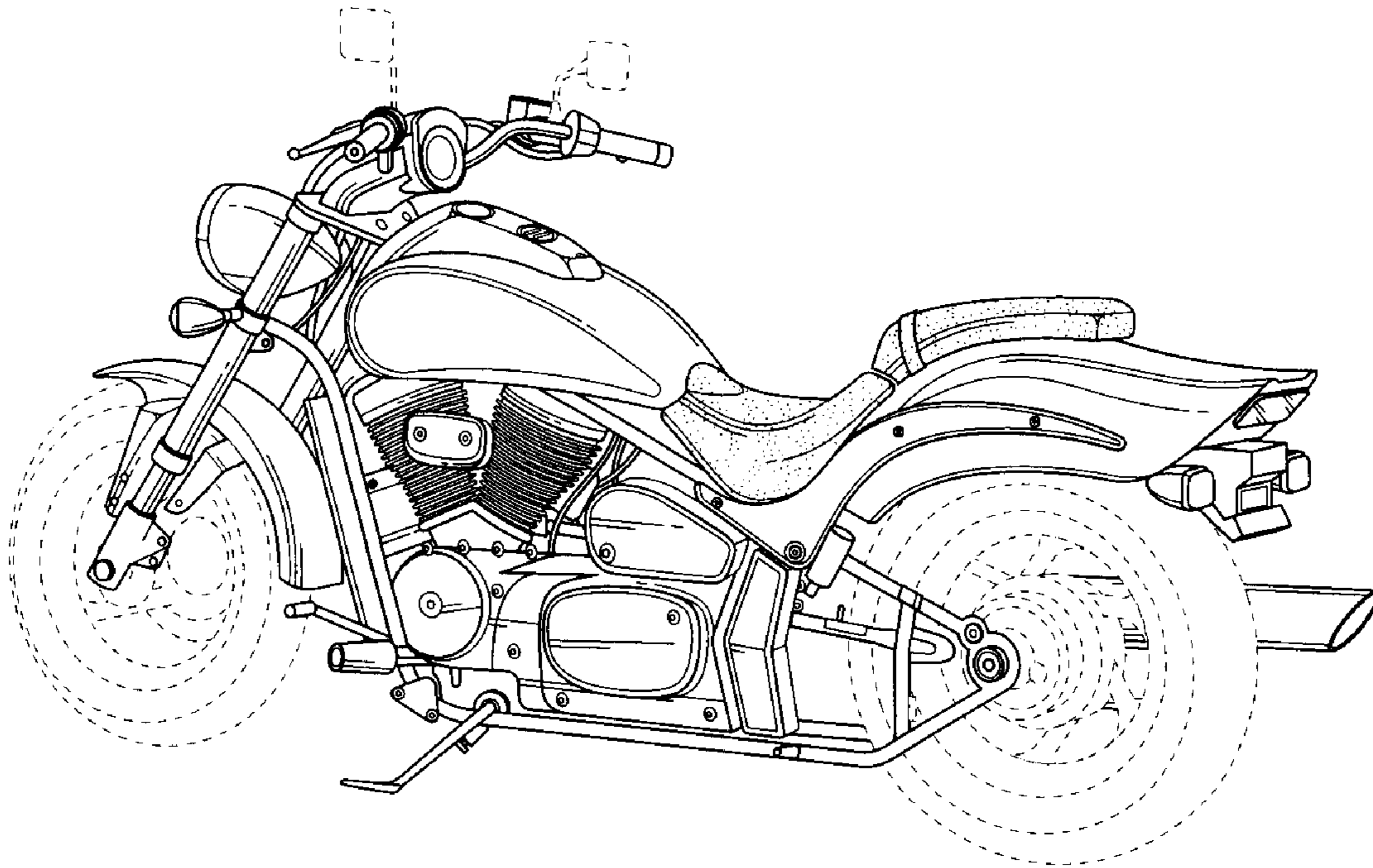

Fig. 4

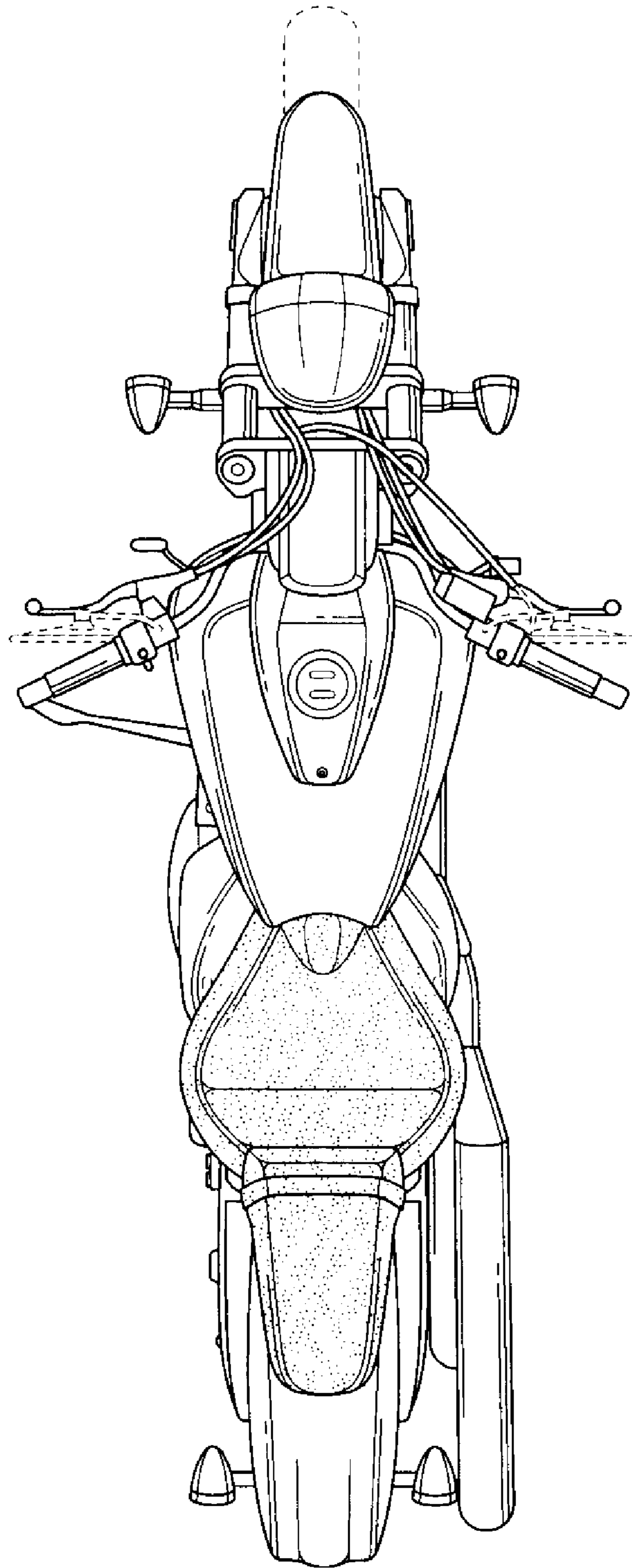

Fig. 5

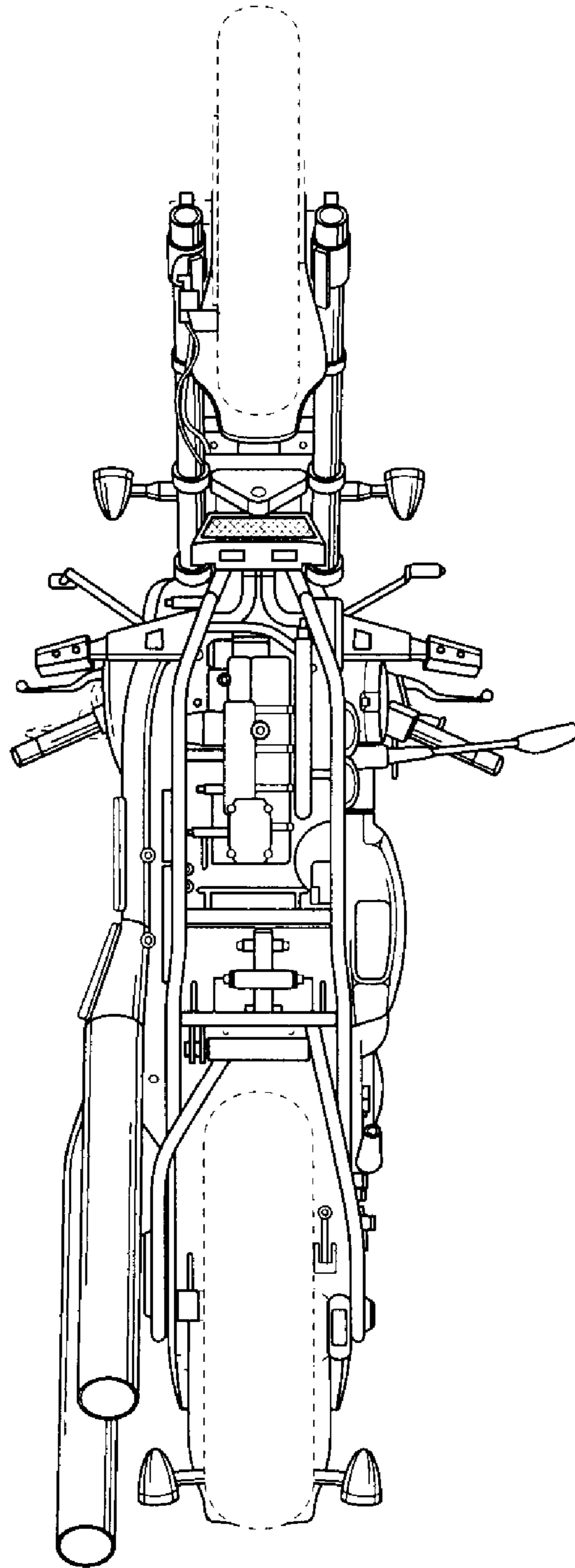

Fig. 6

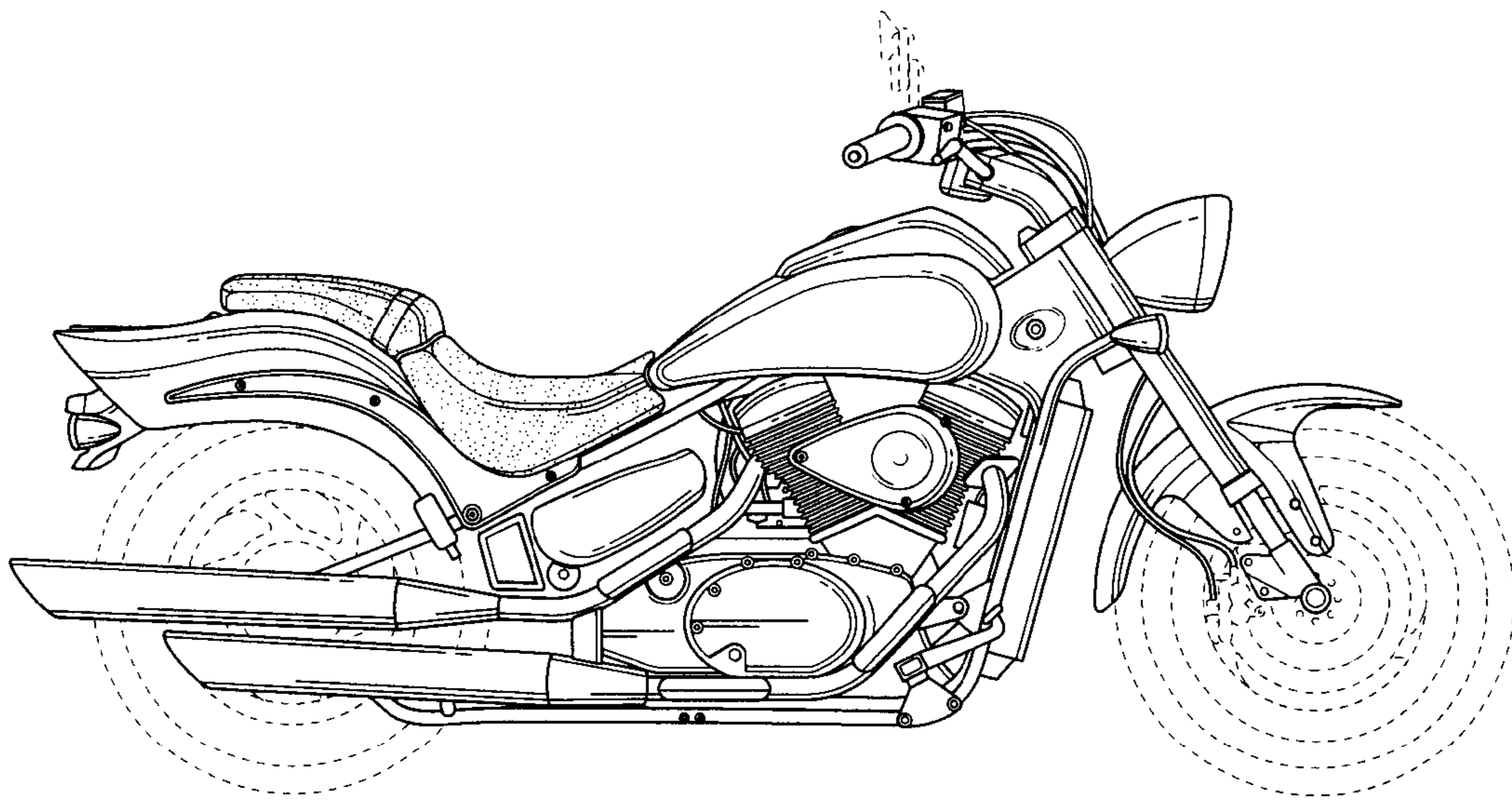

Fig. 7



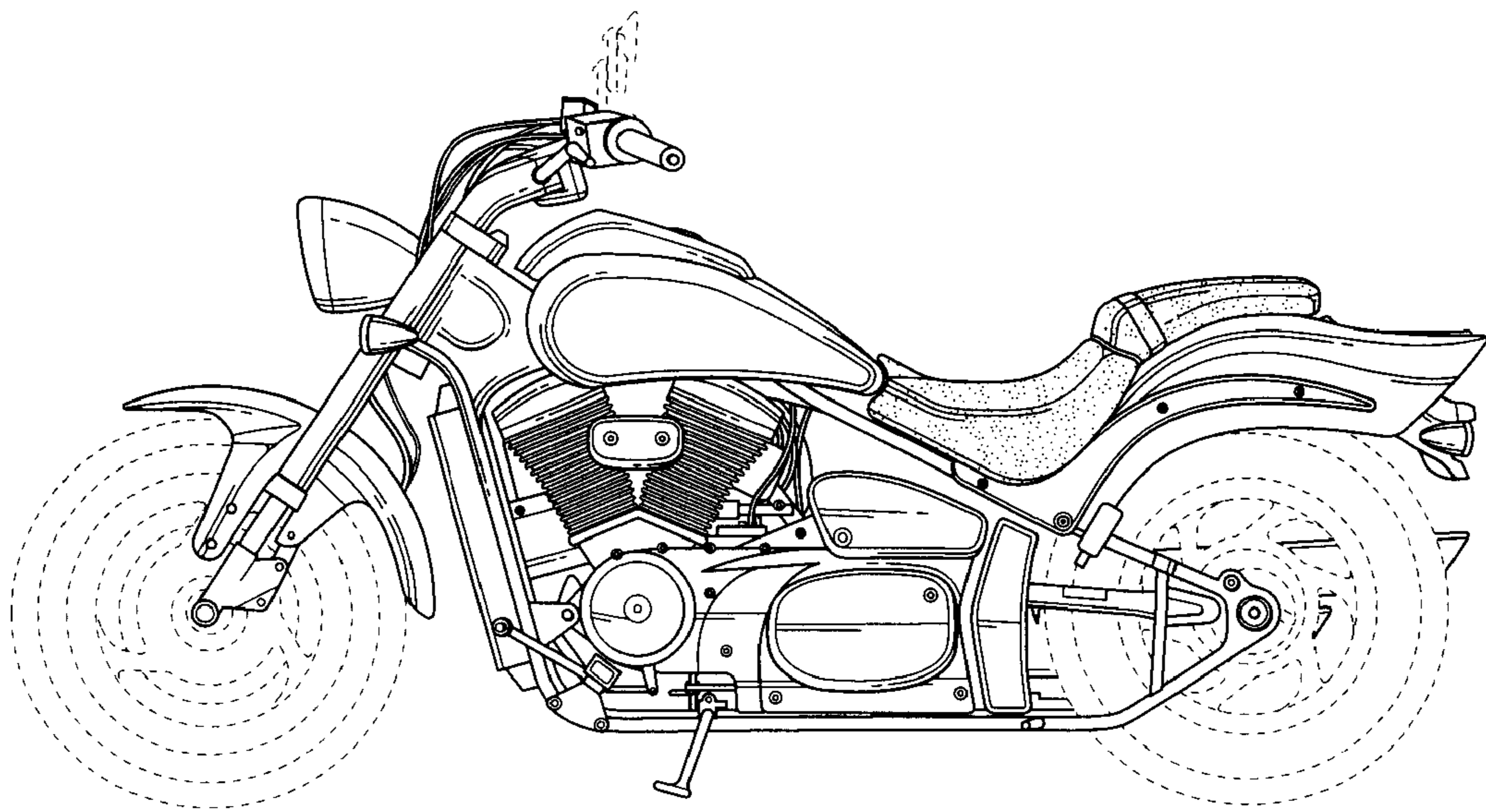

Fig. 8

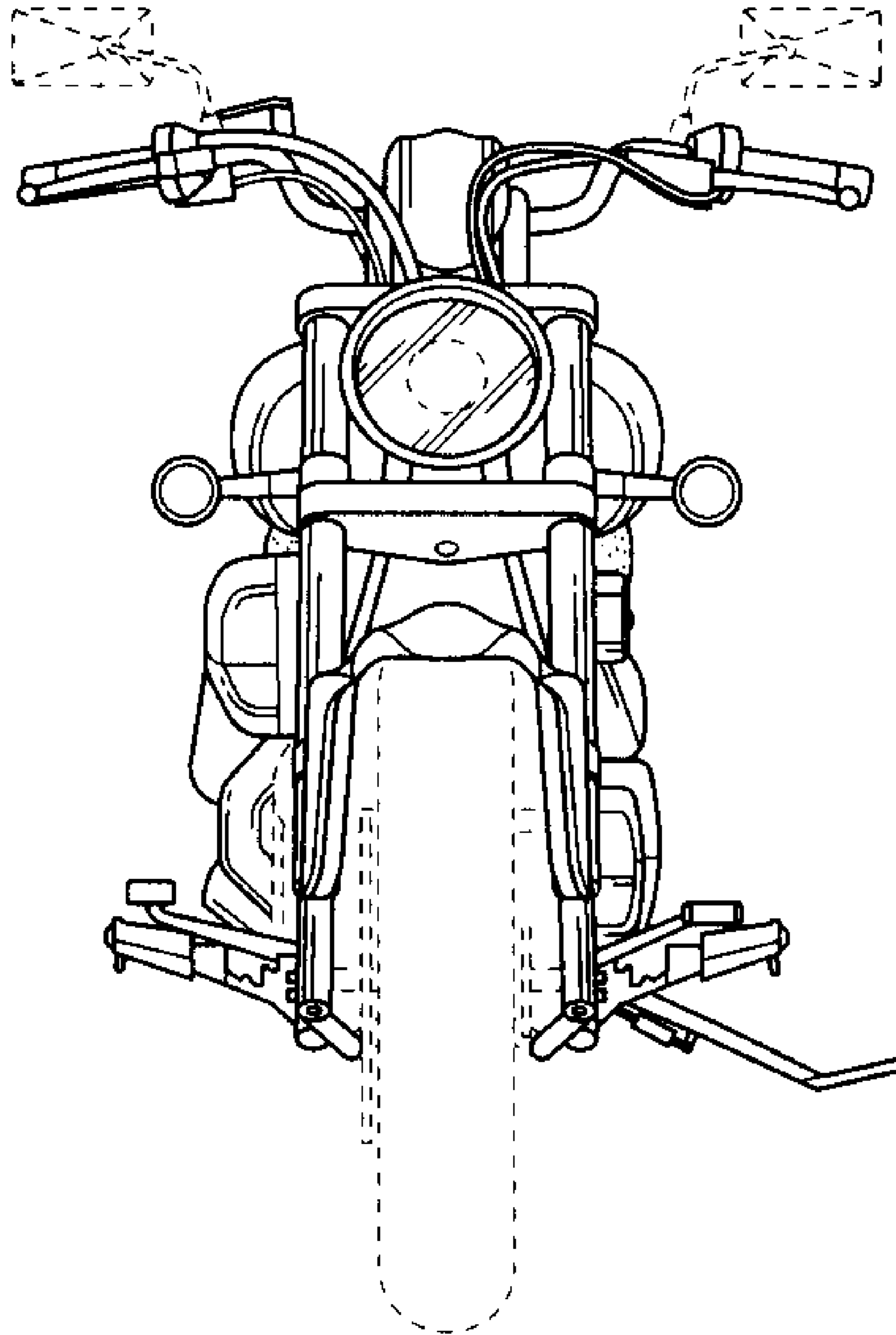

Fig. 9

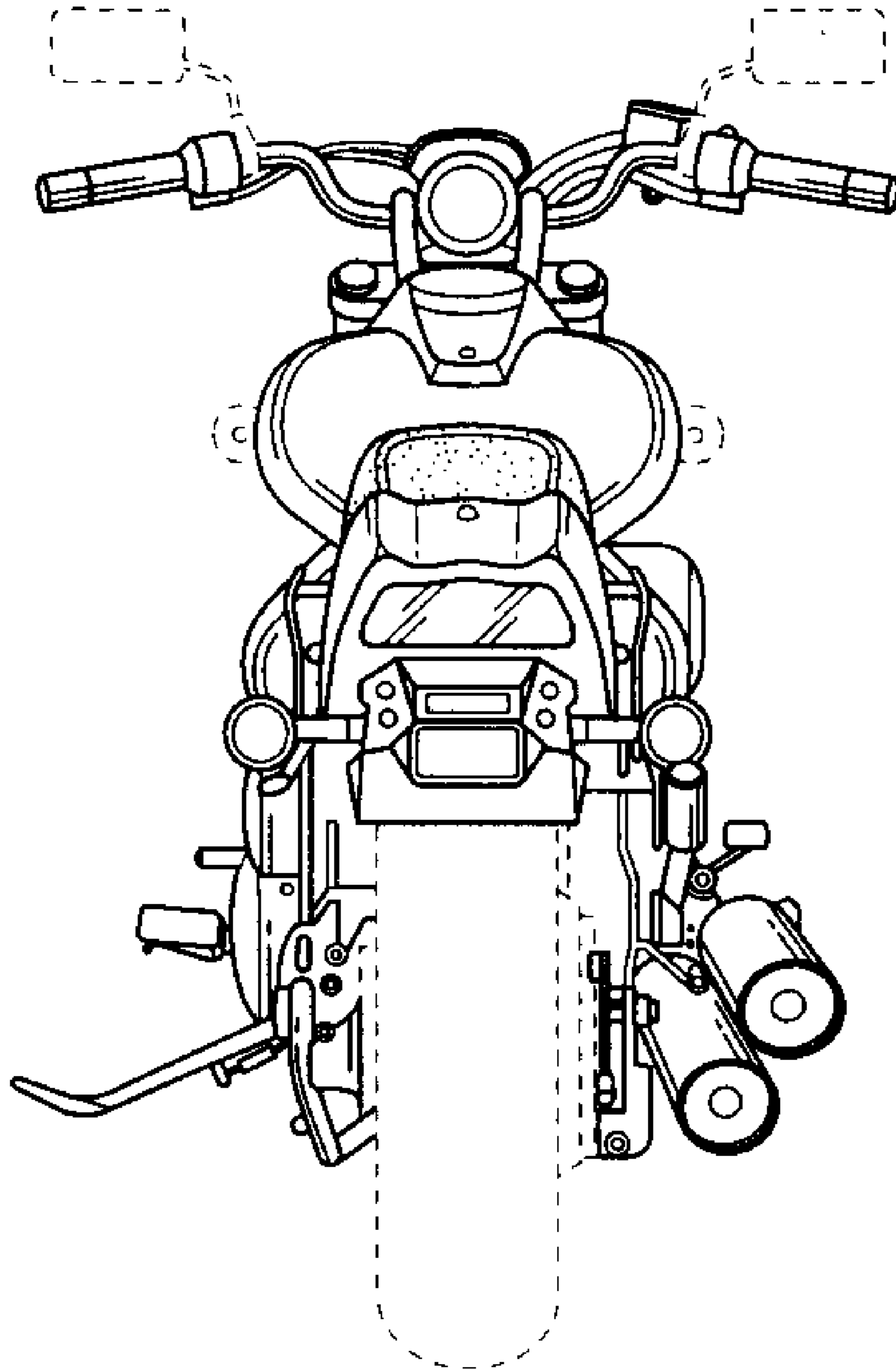

Fig. 10