



US00D522917S

(12) **United States Design Patent**  
**Wagner et al.**

(10) **Patent No.:** **US D522,917 S**

(45) **Date of Patent:** **\*\* Jun. 13, 2006**

(54) **AUTOMOBILE BODY**

D490,353 S \* 5/2004 Gale et al. .... D12/196  
D495,624 S \* 9/2004 Dolan et al. .... D12/91

(75) Inventors: **Lance R Wagner**, Lake Orion, MI (US); **Michael H Nicholas**, Troy, MI (US)

\* cited by examiner

*Primary Examiner*—Melody N. Brown

(74) *Attorney, Agent, or Firm*—Ralph E. Smith

(73) Assignee: **DaimlerChrysler Corporation**, Auburn Hills, MI (US)

(57) **CLAIM**

(\*\*) Term: **14 Years**

The ornamental design for an automobile body, as shown and described.

(21) Appl. No.: **29/231,994**

**DESCRIPTION**

(22) Filed: **Jun. 13, 2005**

FIG. 1 is a front perspective view of an automobile body showing our new design;

(51) **LOC (8) Cl.** ..... **12-08**

FIG. 2 is a side view thereof;

(52) **U.S. Cl.** ..... **D12/91**

FIG. 3 is a front view thereof;

(58) **Field of Classification Search** ..... D12/90–92,

FIG. 4 is a rear view thereof;

D12/86; D21/424, 433; 296/181.1

FIG. 5 is a rear perspective view thereof; and,

See application file for complete search history.

FIG. 6 is a top plan view thereof.

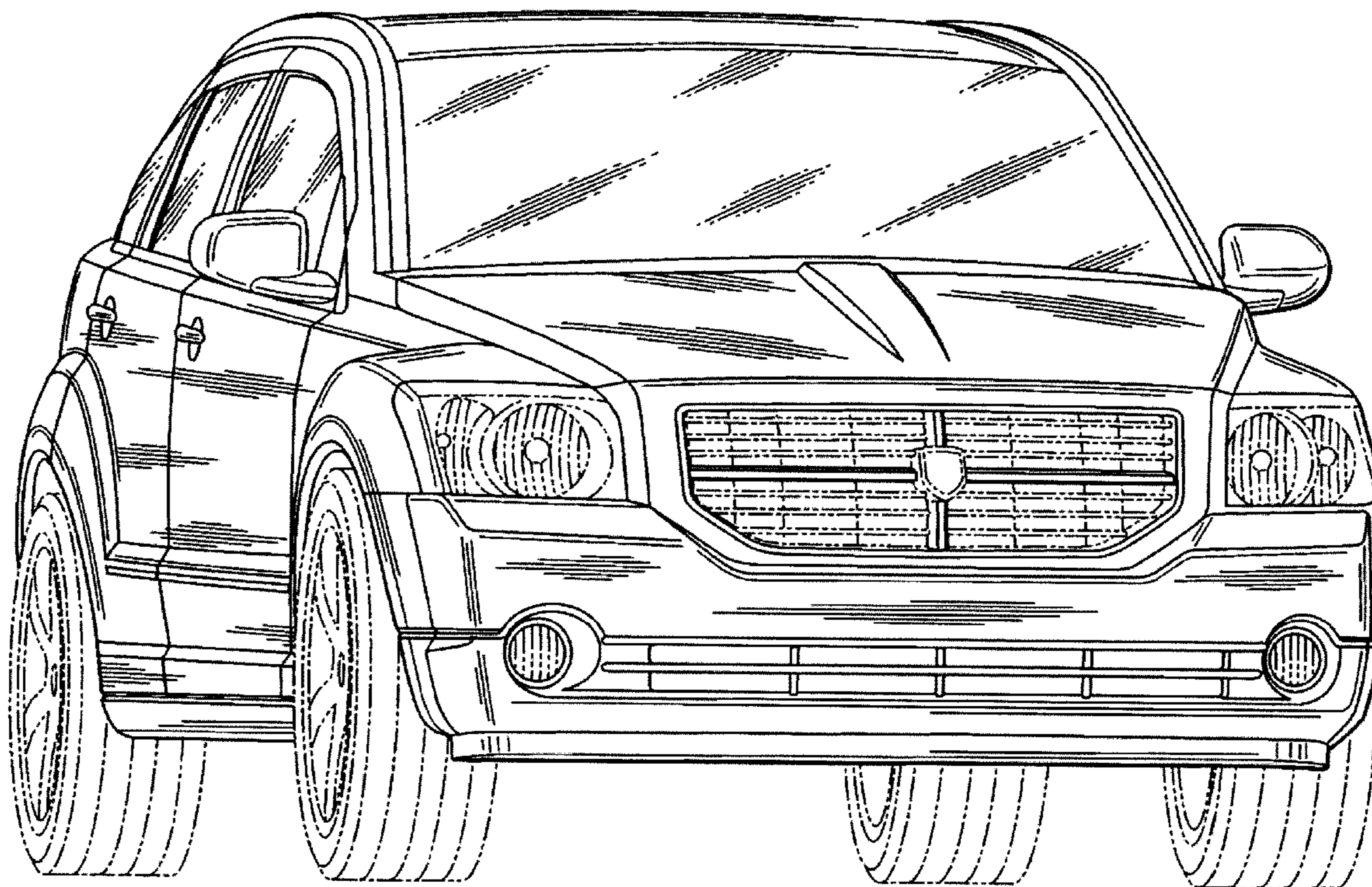
It will be understood that the dashed lines presented in the drawings are for illustration only, and do not form a part of the claimed design.

(56) **References Cited**

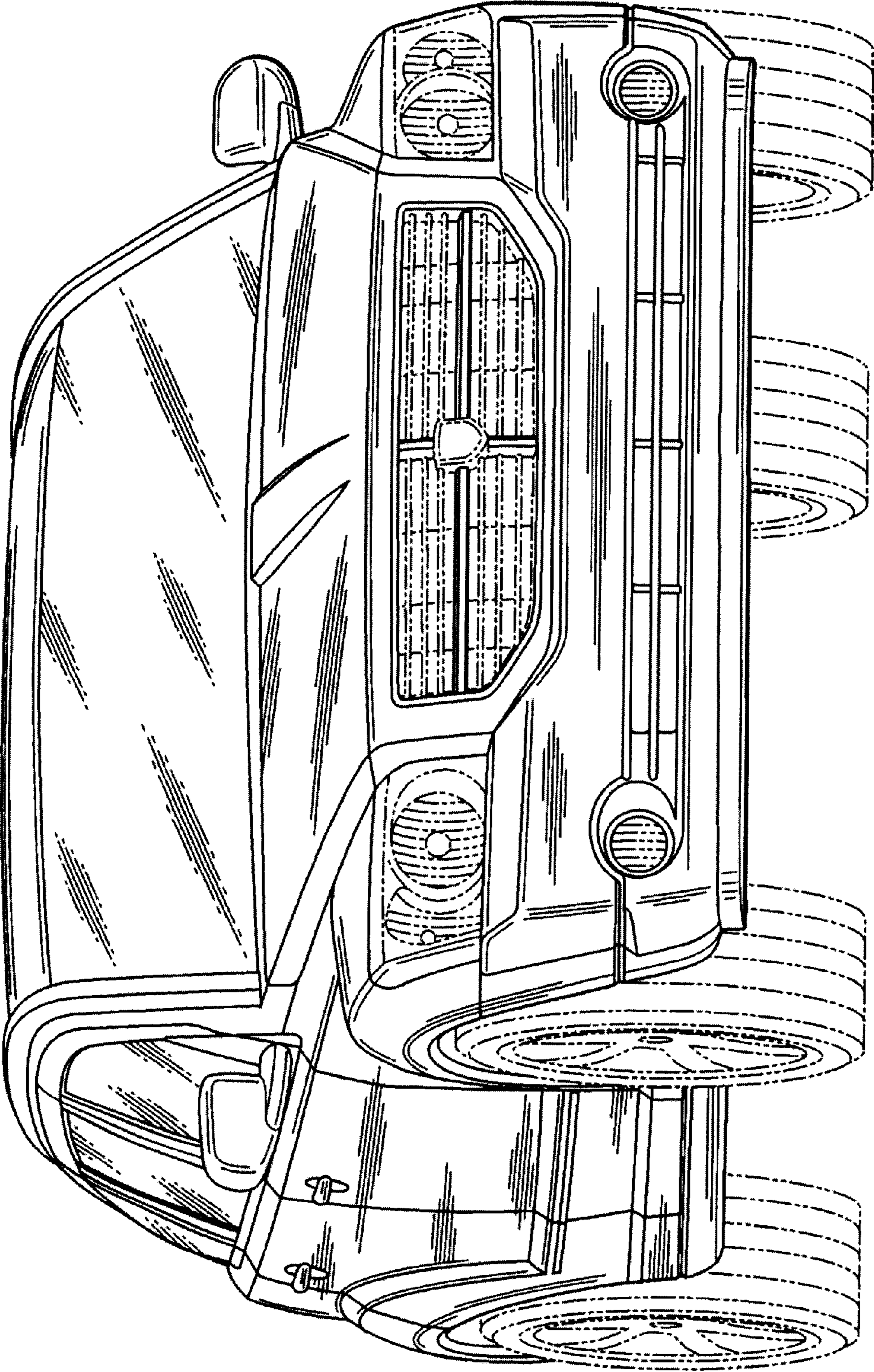
**U.S. PATENT DOCUMENTS**

D479,492 S \* 9/2003 Gale et al. .... D12/91

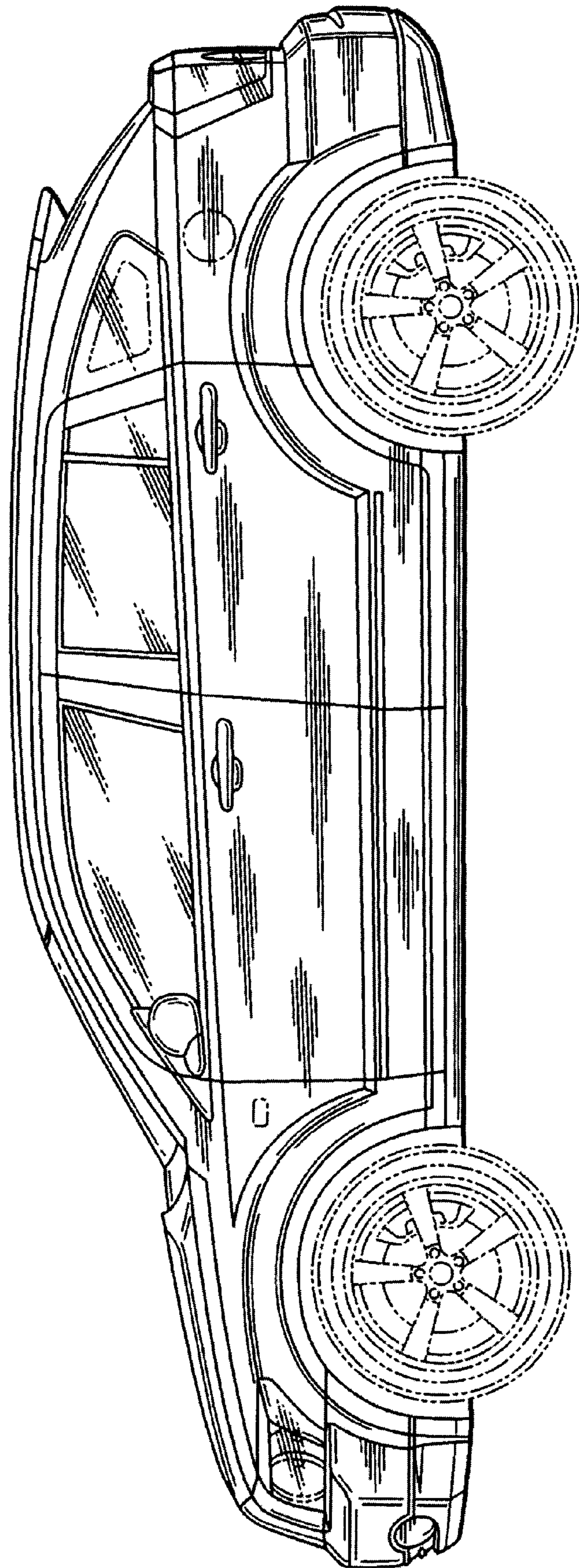
**1 Claim, 5 Drawing Sheets**





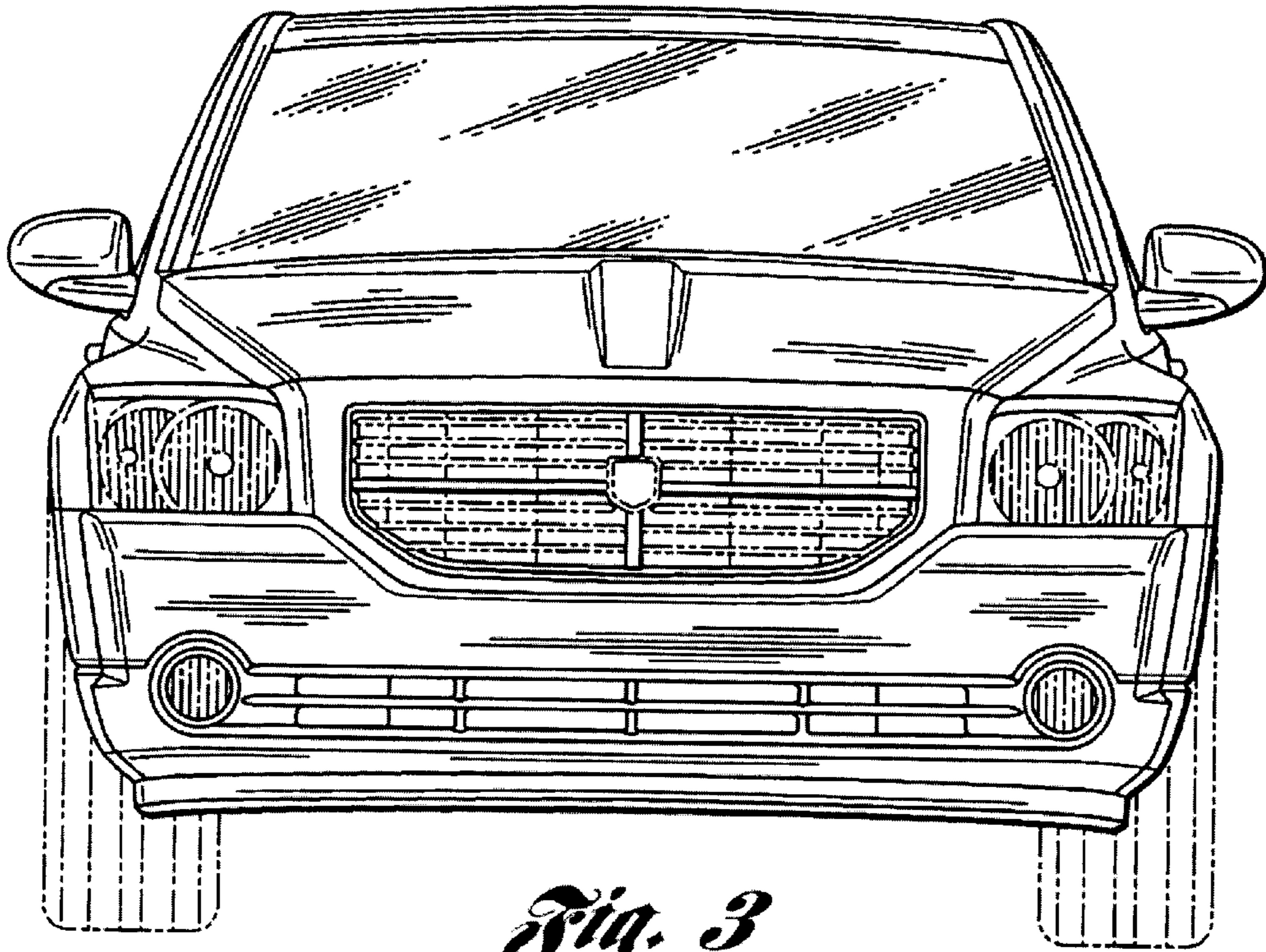


*Fig. 1*

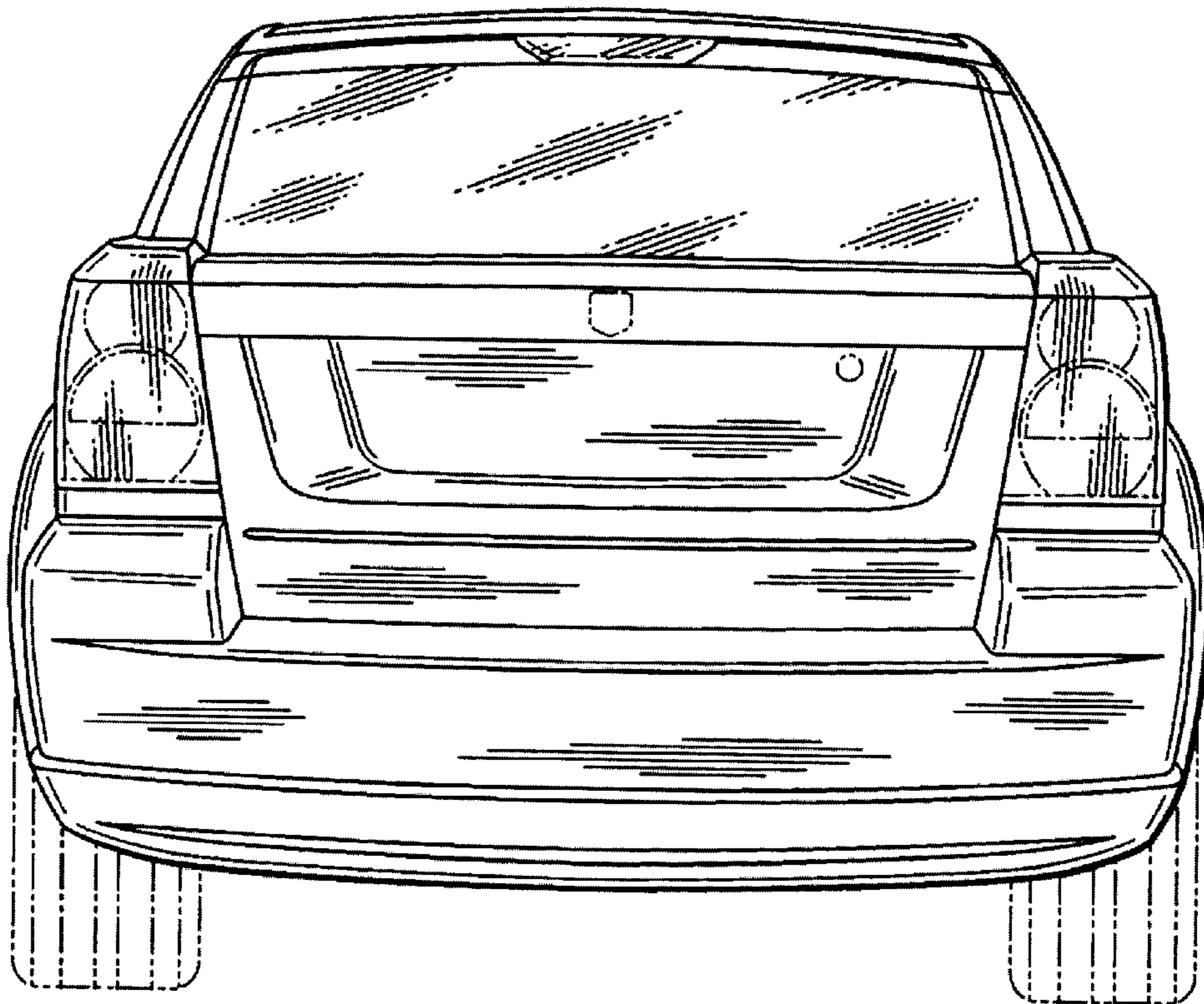


*Fig. 2*

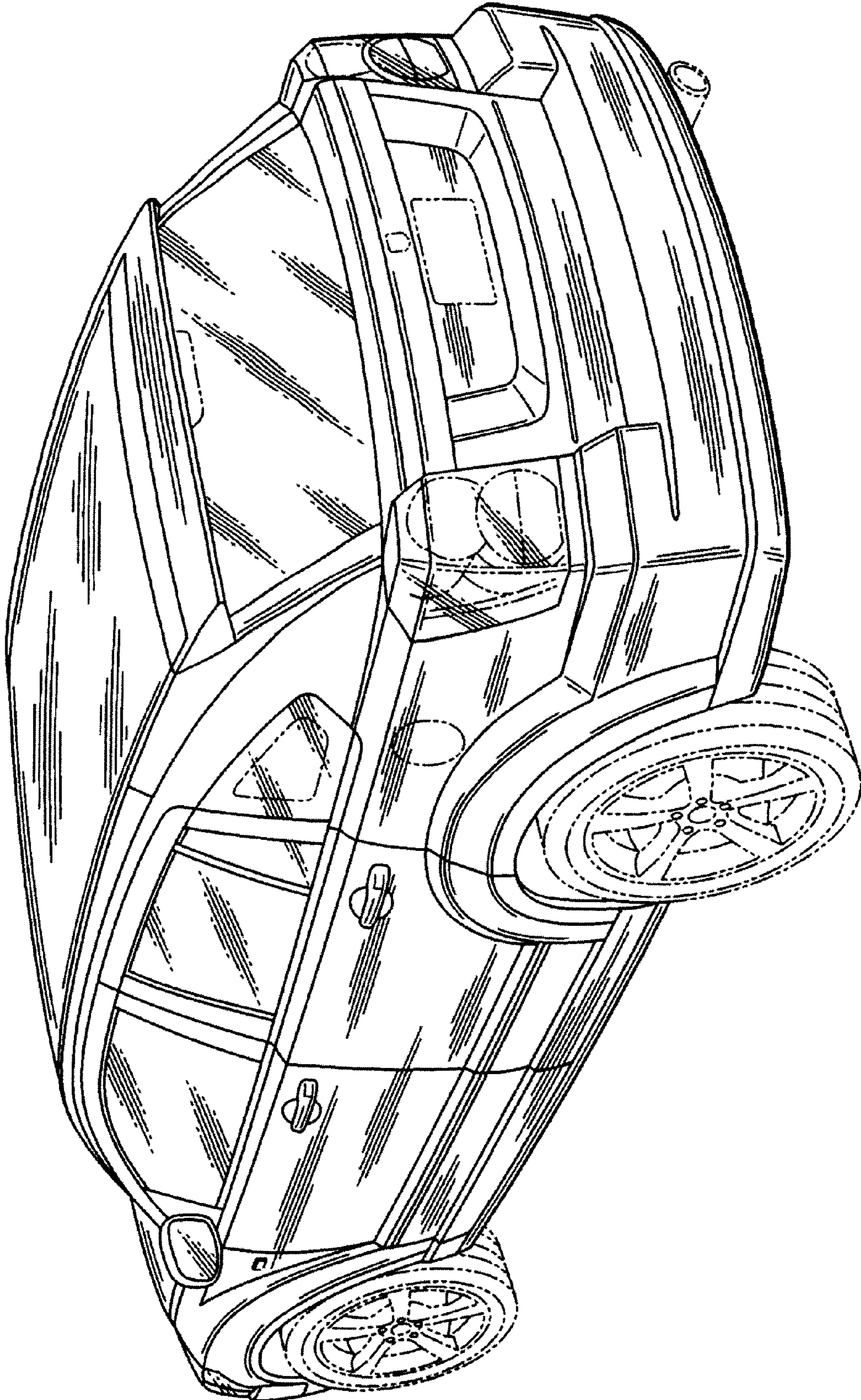




*Fig. 3*

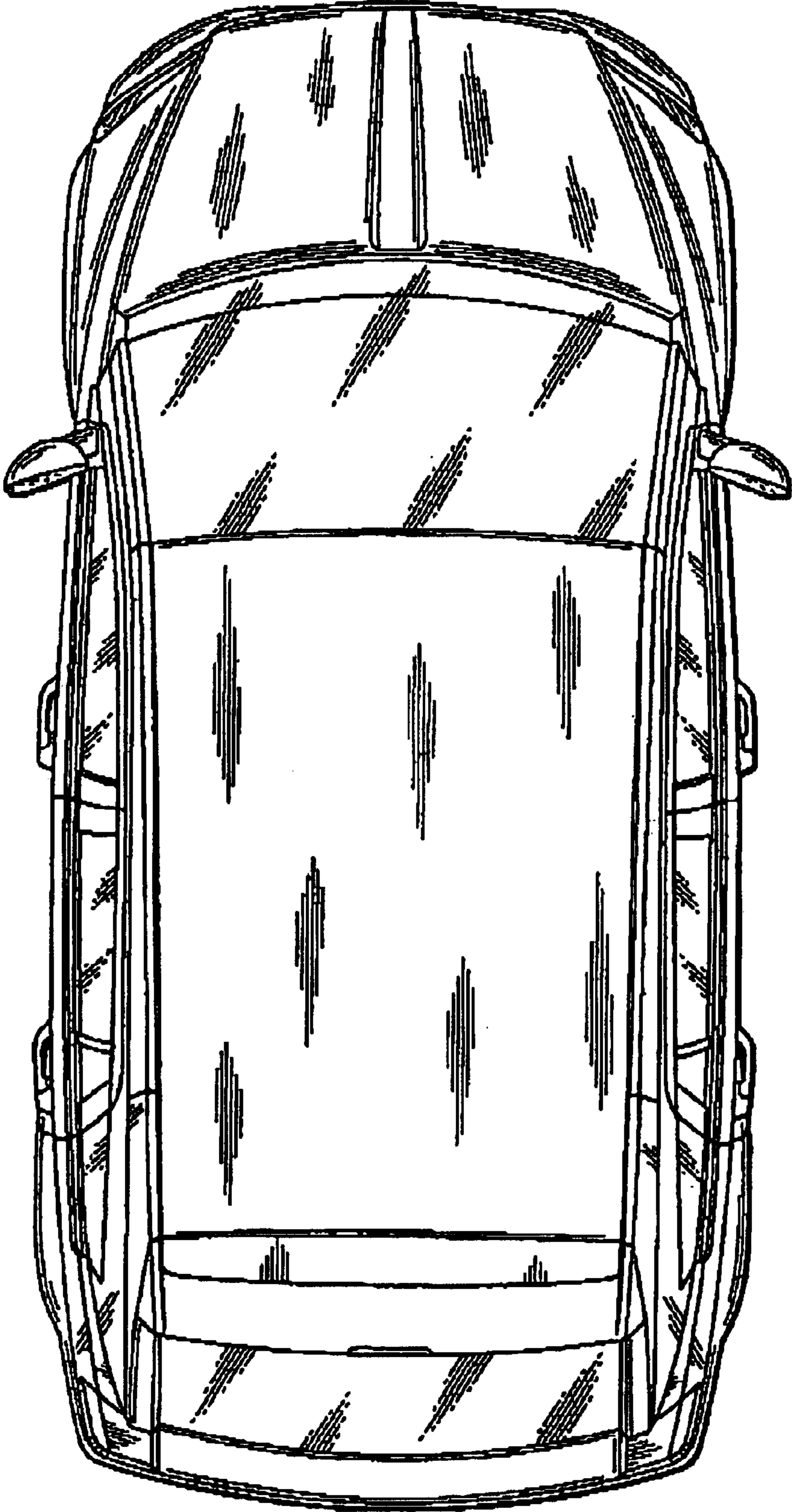


*Fig. 4*



*Fig. 5*





*Fig. 6*