



US00D522827S

(12) **United States Design Patent**
Corcoran

(10) **Patent No.:** **US D522,827 S**
(45) **Date of Patent:** **** Jun. 13, 2006**

(54) **ANGLE GRINDER**

FOREIGN PATENT DOCUMENTS

(75) Inventor: **Michael Corcoran**, Hexam (GB)
(73) Assignee: **Black & Decker Inc.**, Newark, DE (US)
(**) Term: **14 Years**
(21) Appl. No.: **29/222,141**
(22) Filed: **Jan. 26, 2005**
(30) **Foreign Application Priority Data**
Jul. 29, 2004 (EM) 000207212-0001

| | | |
|----|----------------|---------|
| DE | M9701855.4 | 8/1997 |
| DE | M9707886.7 | 1/1998 |
| DE | 49902551.2 | 8/1999 |
| DE | 49908004.1 | 1/2000 |
| DE | 40005179.6 | 10/2000 |
| DE | 40203426.0 | 9/2002 |
| DE | 40205807.0 | 11/2002 |
| DE | 000119011-0001 | 4/2004 |
| FR | 572 690-696 | 3/2000 |
| FR | 707 721-727 | 7/2003 |
| WO | DM 047995 | 2/1999 |
| WO | DM 049836 | 11/1999 |
| WO | DM 052 759 | 8/2000 |
| WO | DM 062266 | 9/2002 |

(51) **LOC (8) Cl.** **08-01**
(52) **U.S. Cl.** **D8/62**
(58) **Field of Classification Search** D8/69,
D8/67, 62, 61; 451/359, 358, 357, 356, 354,
451/353, 351, 344, 294; 173/168
See application file for complete search history.

* cited by examiner

Primary Examiner—Cathron C. Brooks
Assistant Examiner—Austin Murphy
(74) *Attorney, Agent, or Firm*—Bruce S. Shapiro; John Yun; Wesley W. Muller

(56) **References Cited**

(57) **CLAIM**

U.S. PATENT DOCUMENTS

The ornamental design for an angle grinder, as shown and described.

| | | | | |
|----------------|---------|-----------------|-------|---------|
| D107,275 S * | 11/1937 | Albertson | | D8/62 |
| D255,417 S * | 6/1980 | Sakamoto et al. | | D8/62 |
| D295,824 S * | 5/1988 | Hoshino et al. | | D8/62 |
| D396,175 S * | 7/1998 | Chung | | D8/62 |
| 6,132,301 A * | 10/2000 | Kaiser | | 451/450 |
| 6,241,594 B1 * | 6/2001 | Lepold | | 451/359 |
| D453,288 S * | 2/2002 | Lui | | D8/62 |
| D475,263 S * | 6/2003 | Andriolo | | D8/62 |
| D491,033 S * | 6/2004 | Bian | | D8/62 |
| D494,827 S * | 8/2004 | Liu | | D8/62 |
| D498,653 S * | 11/2004 | Wu | | D8/62 |
| 6,872,121 B1 * | 3/2005 | Wiesner et al. | | 451/5 |
| 6,893,334 B1 * | 5/2005 | Stivers | | 451/359 |

DESCRIPTION

FIG. 1 is a left/front perspective view of an angle grinder showing my new design.
FIG. 2 is a front view thereof.
FIG. 3 is a rear view thereof.
FIG. 4 is a left side view thereof.
FIG. 5 is a right side view thereof.
FIG. 6 is a top plan view thereof; and,
FIG. 7 is a bottom plan view thereof.

1 Claim, 5 Drawing Sheets

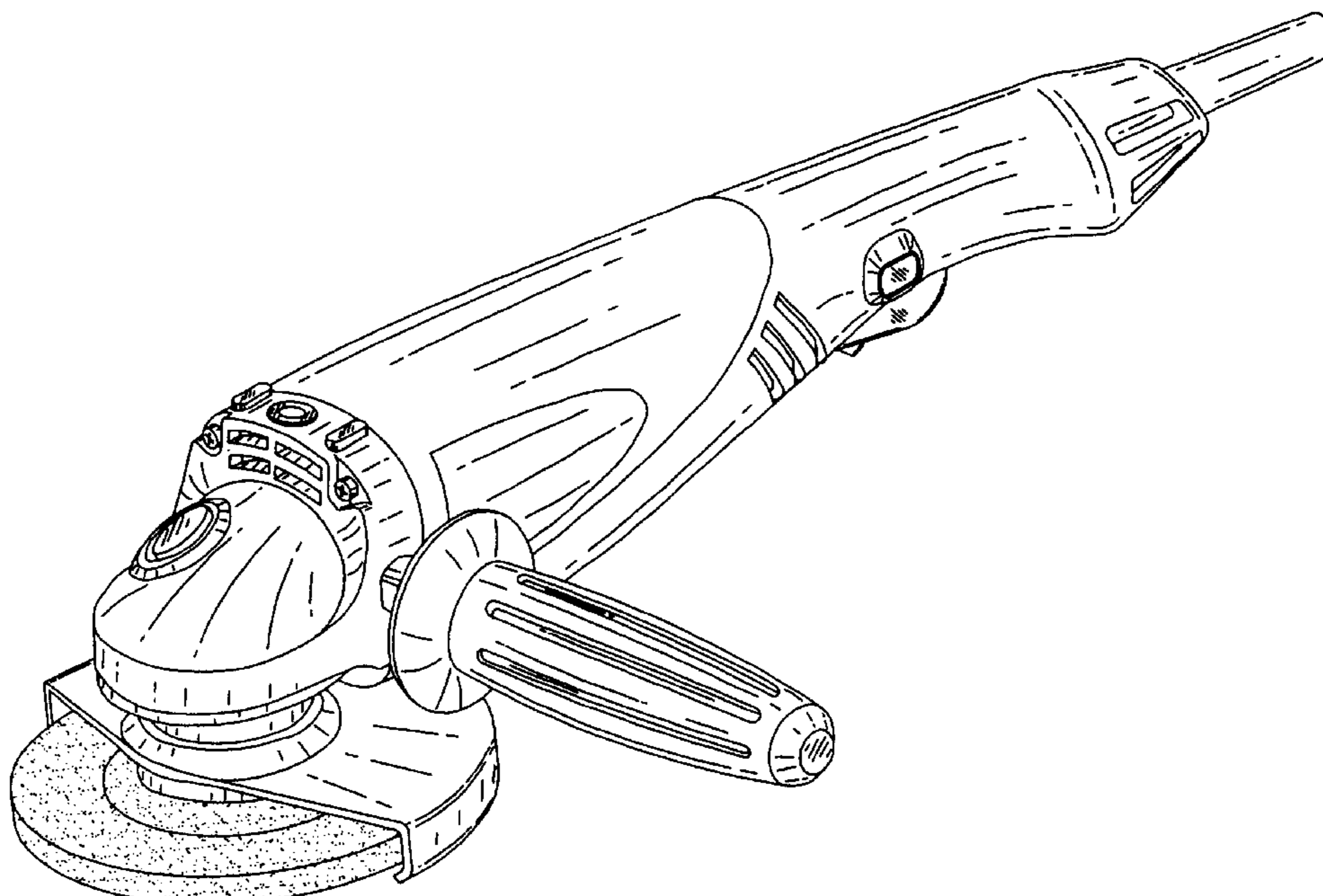

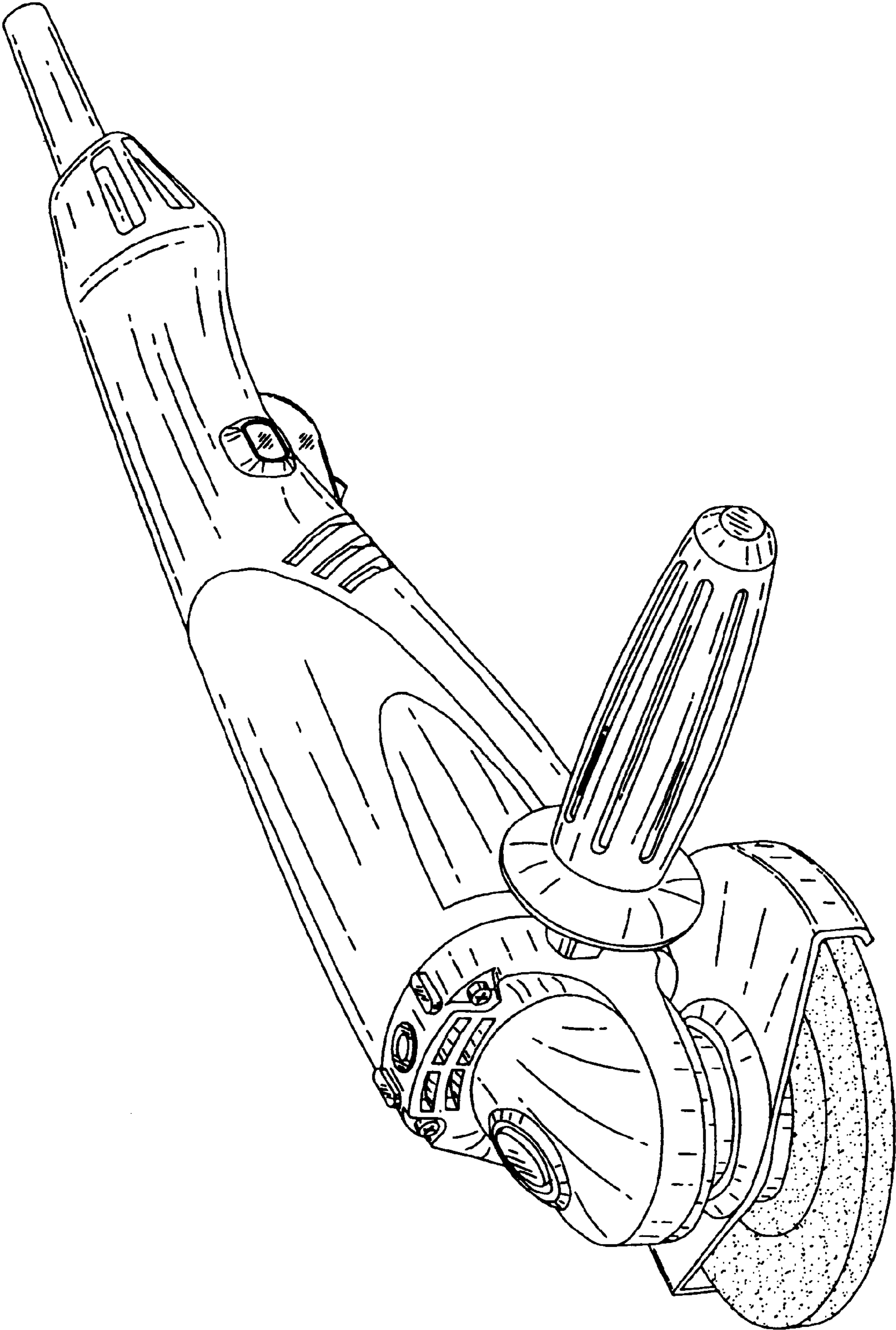

FIG.1

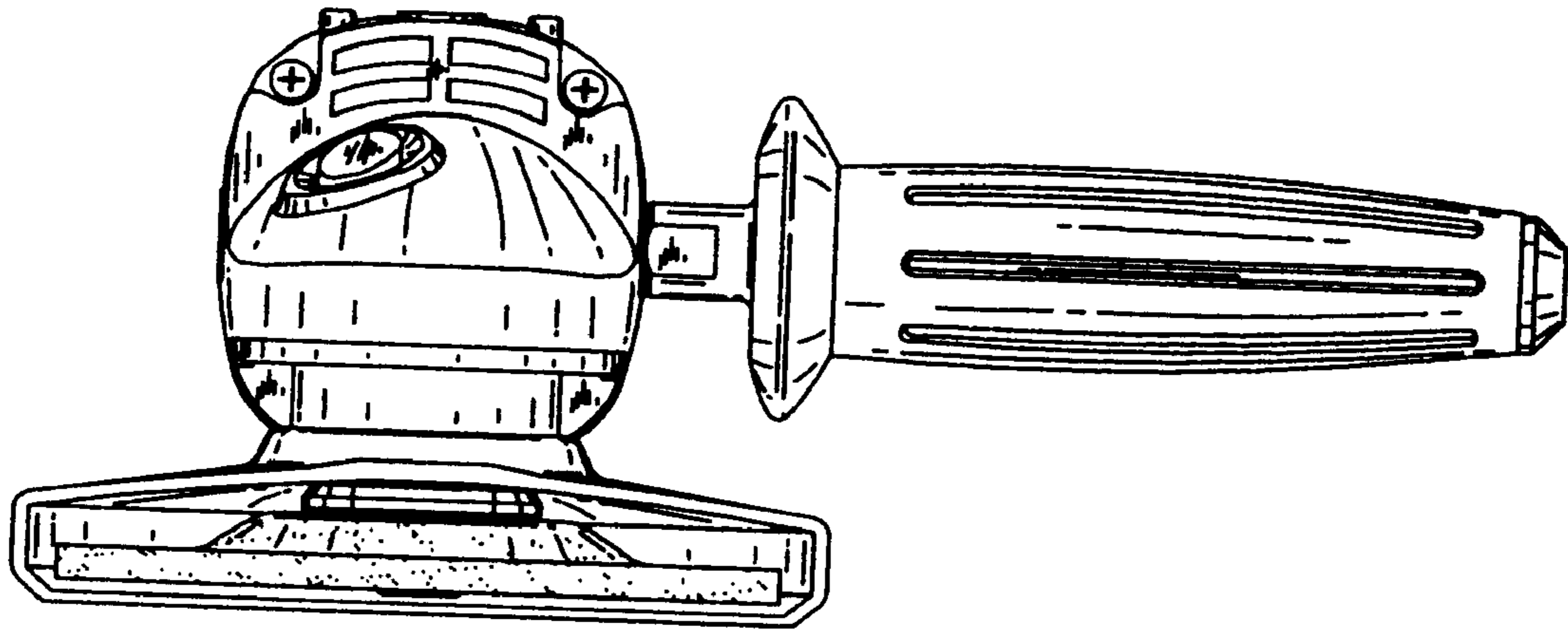

FIG. 2

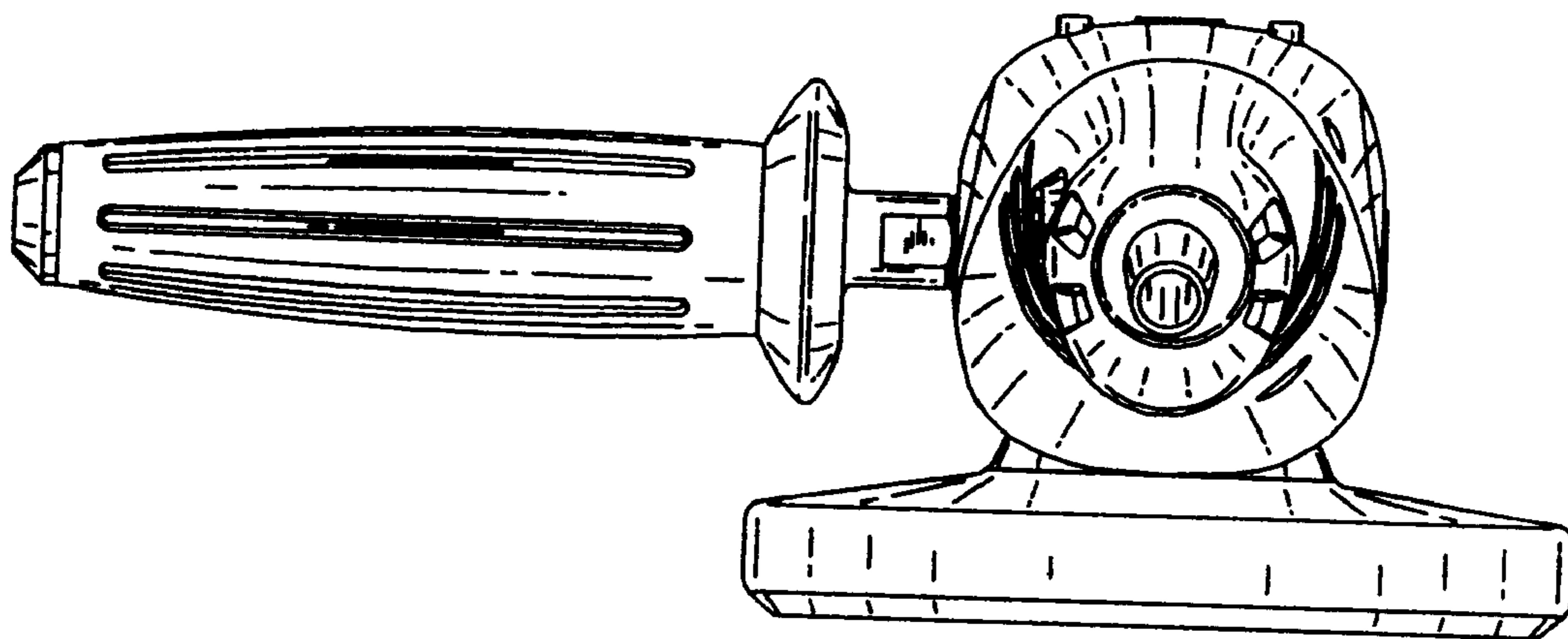

FIG. 3

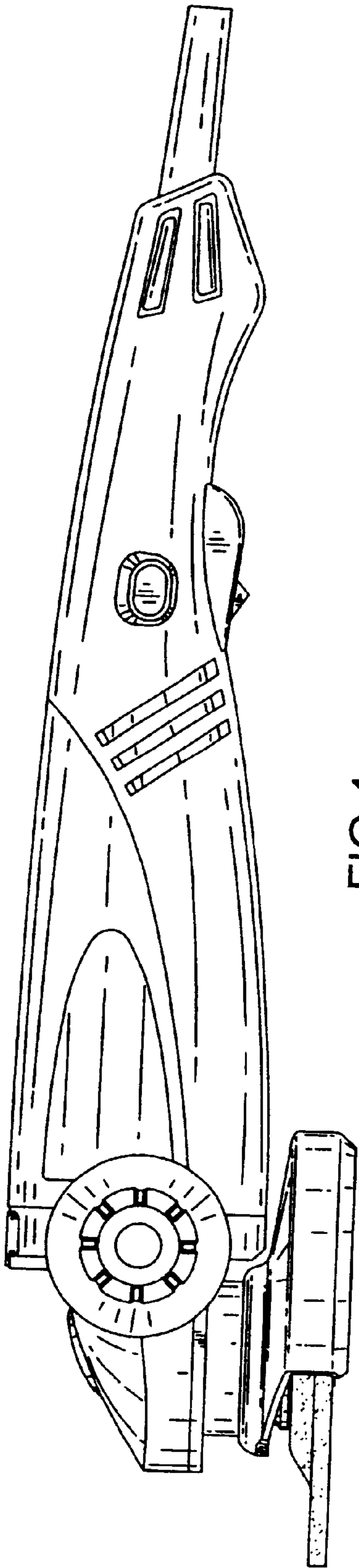

FIG. 4

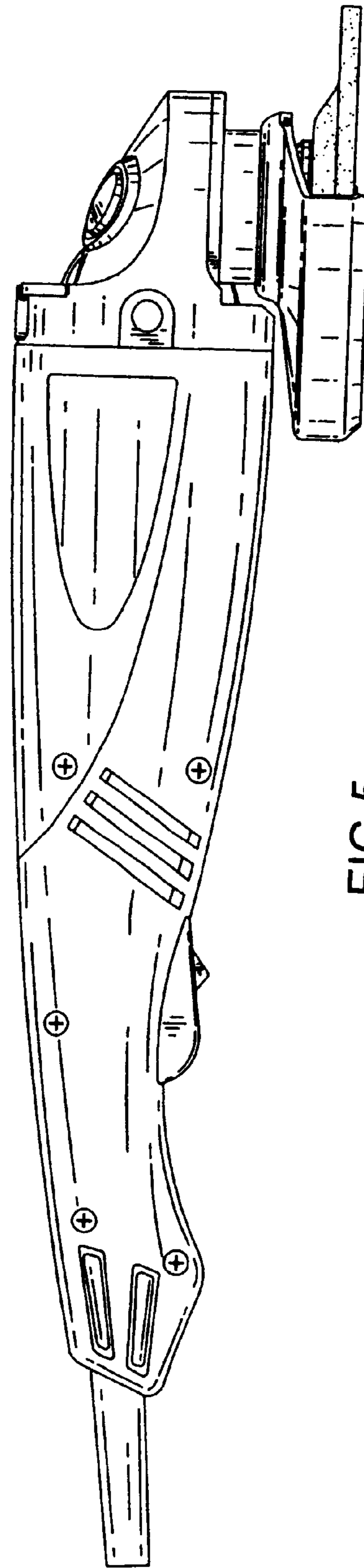

FIG. 5

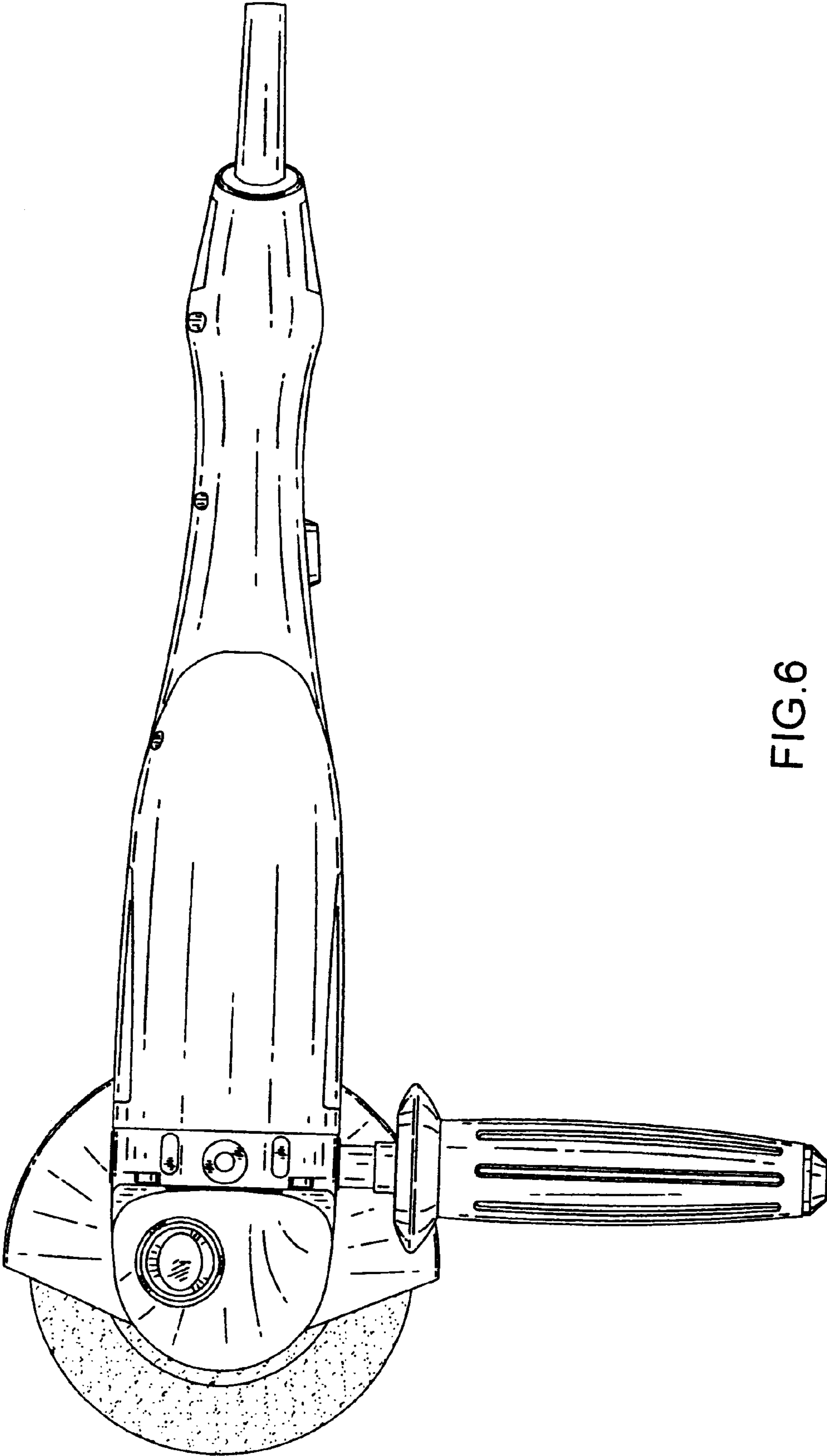

FIG.6

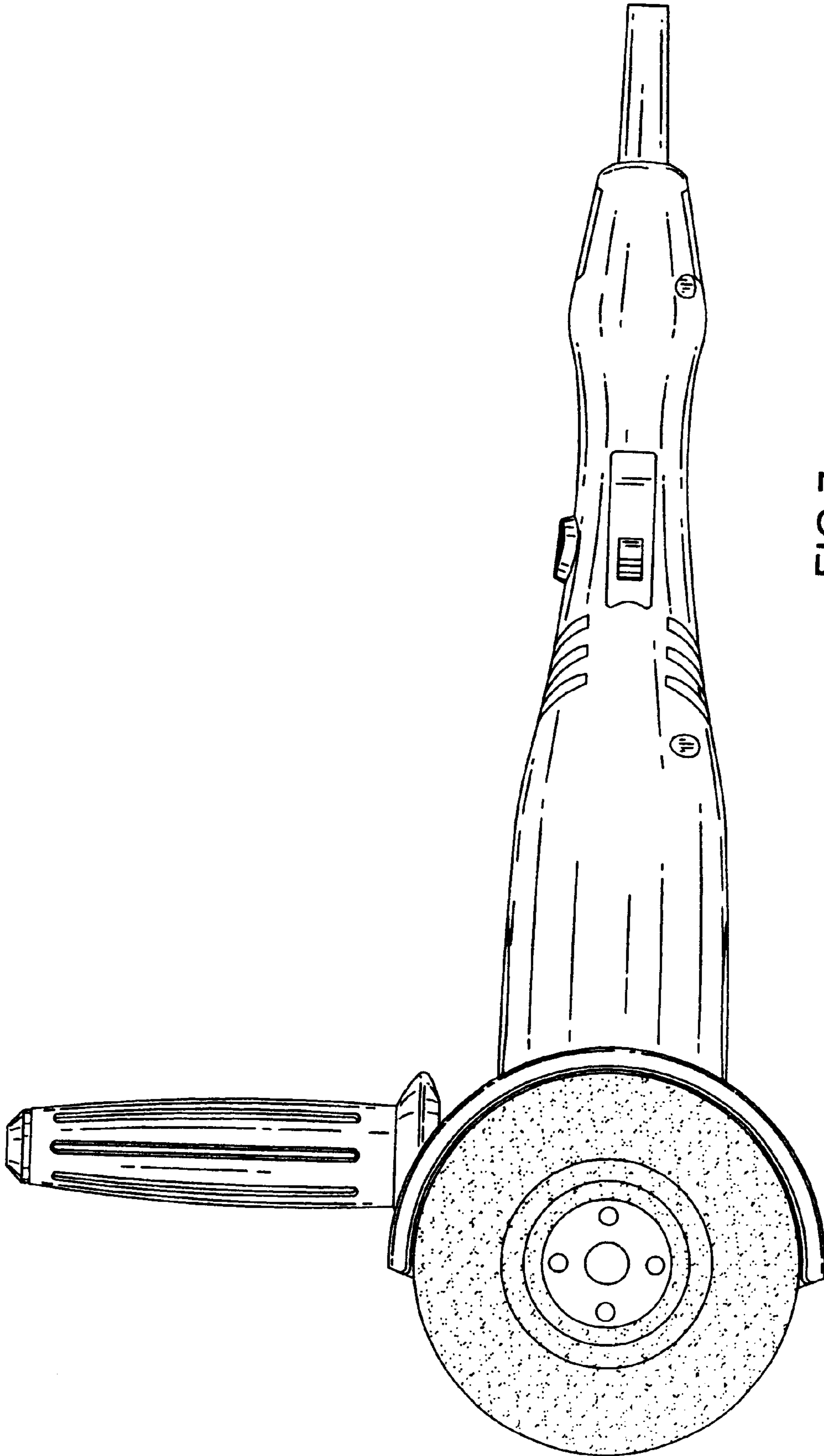

FIG.7