



US00D522587S

(12) **United States Design Patent**
Yokoi

(10) **Patent No.:** **US D522,587 S**
(45) **Date of Patent:** **** Jun. 6, 2006**

(54) **PORTABLE LIQUID-CRYSTAL GAME MACHINE**

(75) Inventor: **Akihiro Yokoi**, Tokyo (JP)

(73) Assignee: **Kabushiki Kaisha Wiz** (JP)

(**) Term: **14 Years**

(21) Appl. No.: **29/221,204**

(22) Filed: **Jan. 12, 2005**

(30) **Foreign Application Priority Data**

Sep. 29, 2004 (JP) 2004-029462

(51) **LOC (8) Cl.** **21-01**

(52) **U.S. Cl.** **D21/324; D21/328**

(58) **Field of Classification Search** D21/300,
D21/439, 324-333, 440, 403, 478; D14/496;
273/148 B, 457, DIG. 14, DIG. 24; 463/1,
463/29-35, 46, 47; 252/299.01, 582, 586,
252/301.16; 349/1, 16, 58, 61, 190; 359/616,
359/617, 894, 895

See application file for complete search history.

(56) **References Cited**

U.S. PATENT DOCUMENTS

D212,771 S * 11/1968 Gordon D21/403
4,776,653 A * 10/1988 Kaplan 359/616
D319,852 S * 9/1991 Sorensen et al. D21/403

5,180,222 A * 1/1993 Robinson 362/125
D378,677 S * 4/1997 Matsumoto et al. D14/496
5,822,520 A * 10/1998 Parker 709/230
6,055,098 A * 4/2000 Lett 359/402
6,092,698 A * 7/2000 Bayer 222/402.25
6,310,730 B1 * 10/2001 Knapp et al. 359/642
6,491,216 B1 * 12/2002 May 235/375
D481,397 S * 10/2003 Ashida et al. D14/496
6,692,001 B1 * 2/2004 Romano 273/157 A
6,737,631 B1 * 5/2004 Martens et al. 250/221

* cited by examiner

Primary Examiner—Prabhakar Deshmukh

(74) *Attorney, Agent, or Firm*—SAIDMAN DesignLaw Group

(57) **CLAIM**

The ornamental design for a portable liquid-crystal game machine, as shown and described.

DESCRIPTION

FIG. 1 is a perspective view of a portable liquid-crystal game machine showing my new design;
FIG. 2 is a front view thereof;
FIG. 3 is a rear view thereof;
FIG. 4 is a right side view thereof;
FIG. 5 is a left side view thereof;
FIG. 6 is a top view thereof; and,
FIG. 7 is a bottom view thereof.

1 Claim, 4 Drawing Sheets

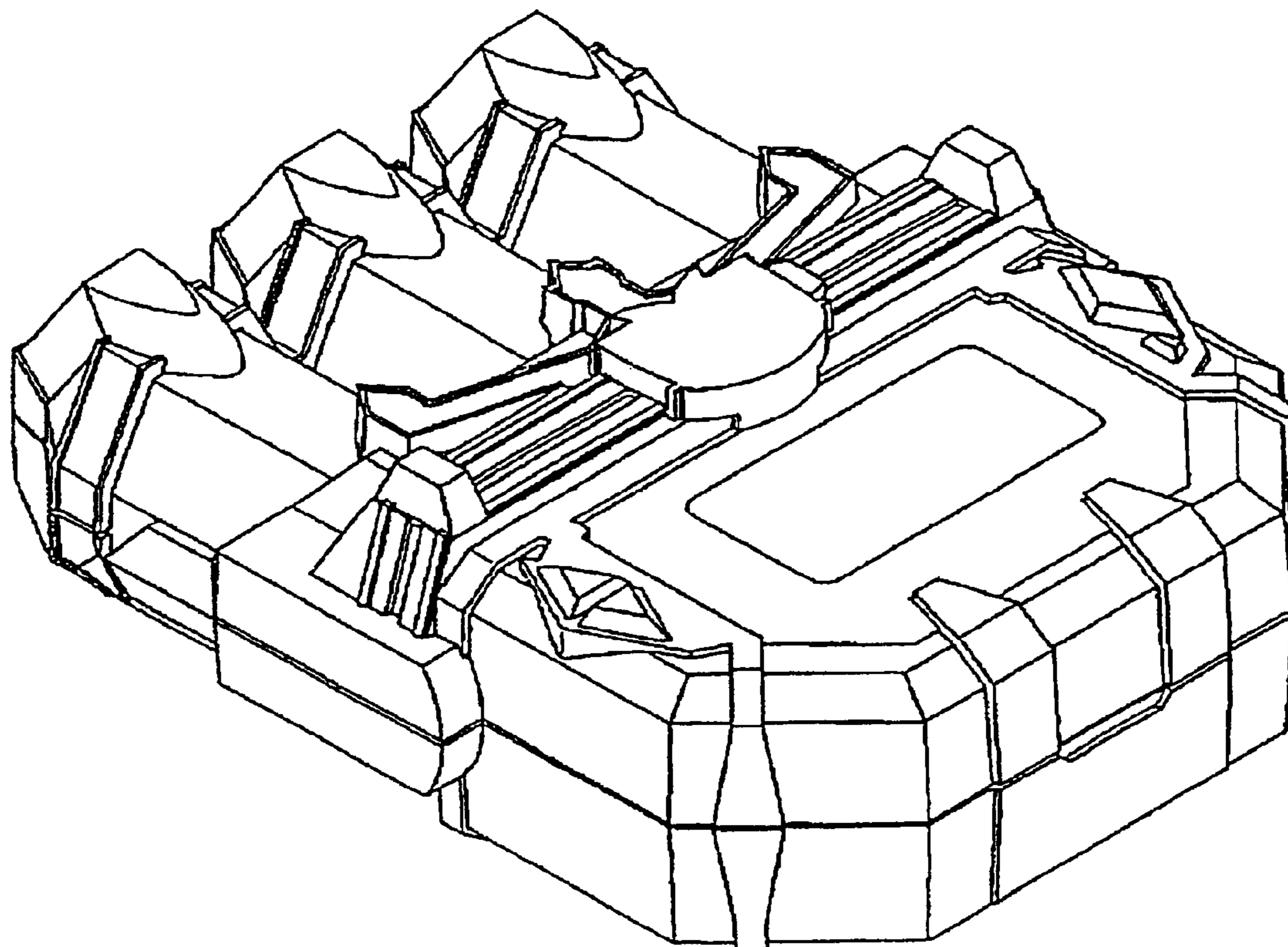

FIG. 1

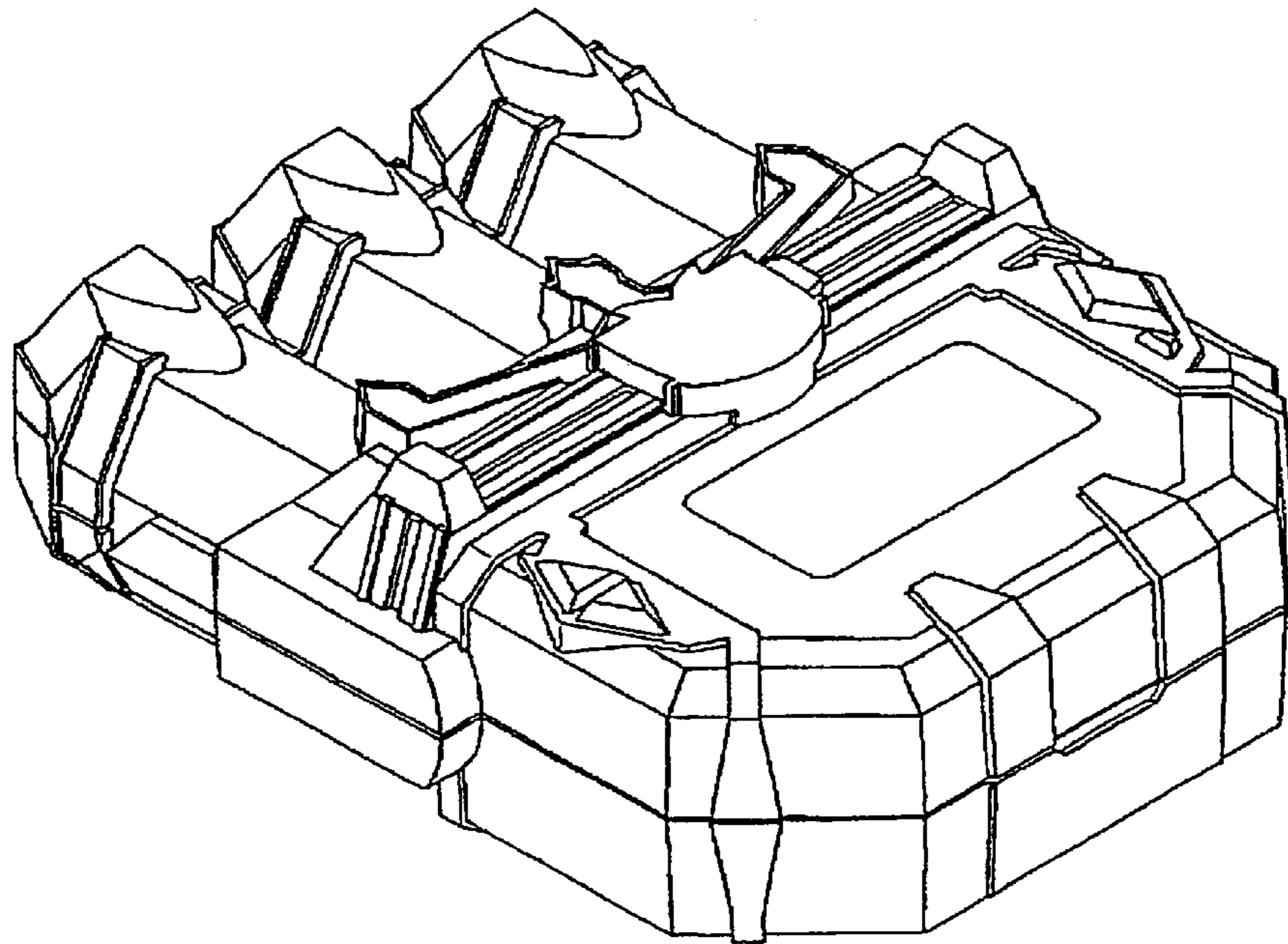

FIG. 2

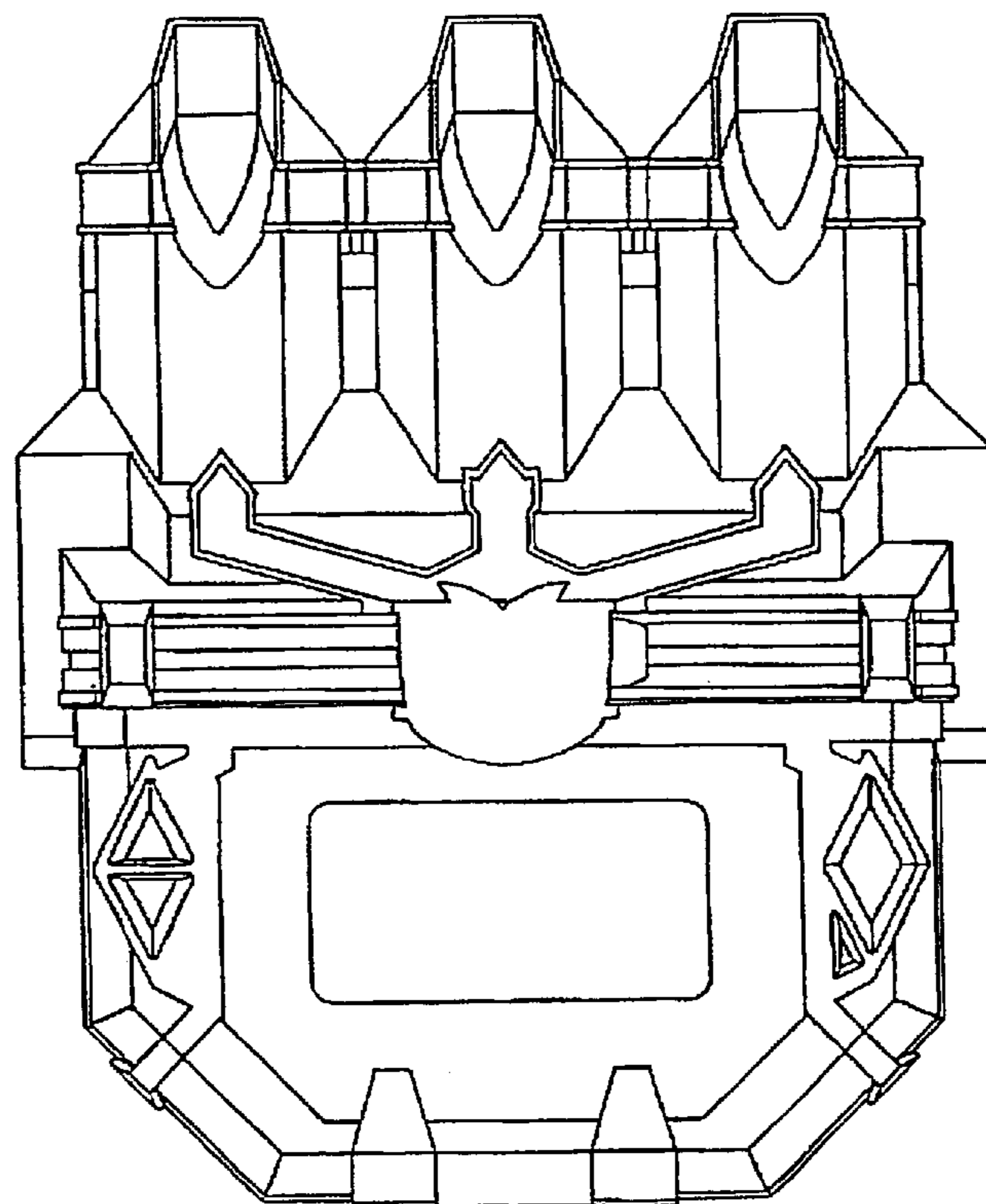

FIG. 3

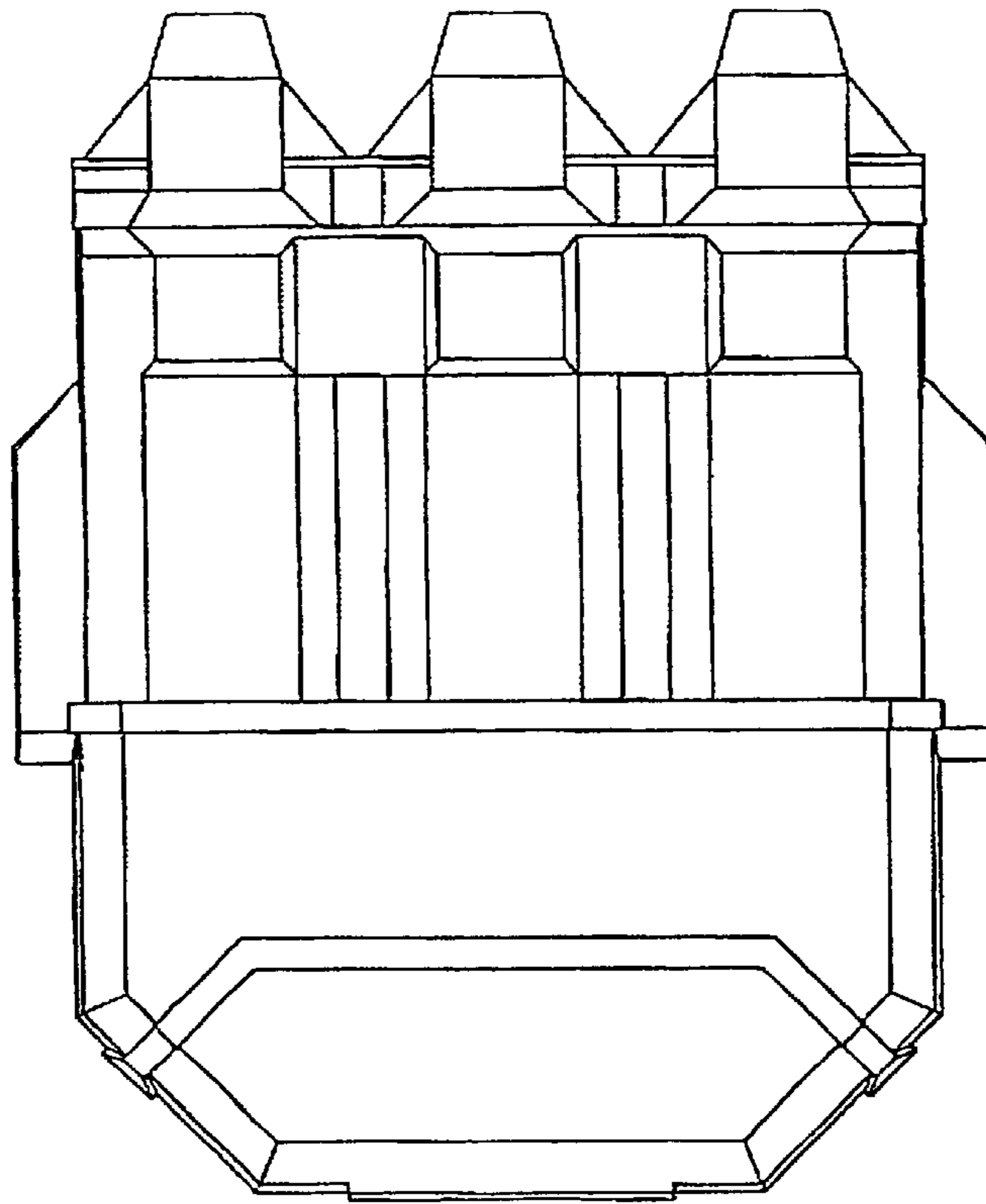

FIG. 4

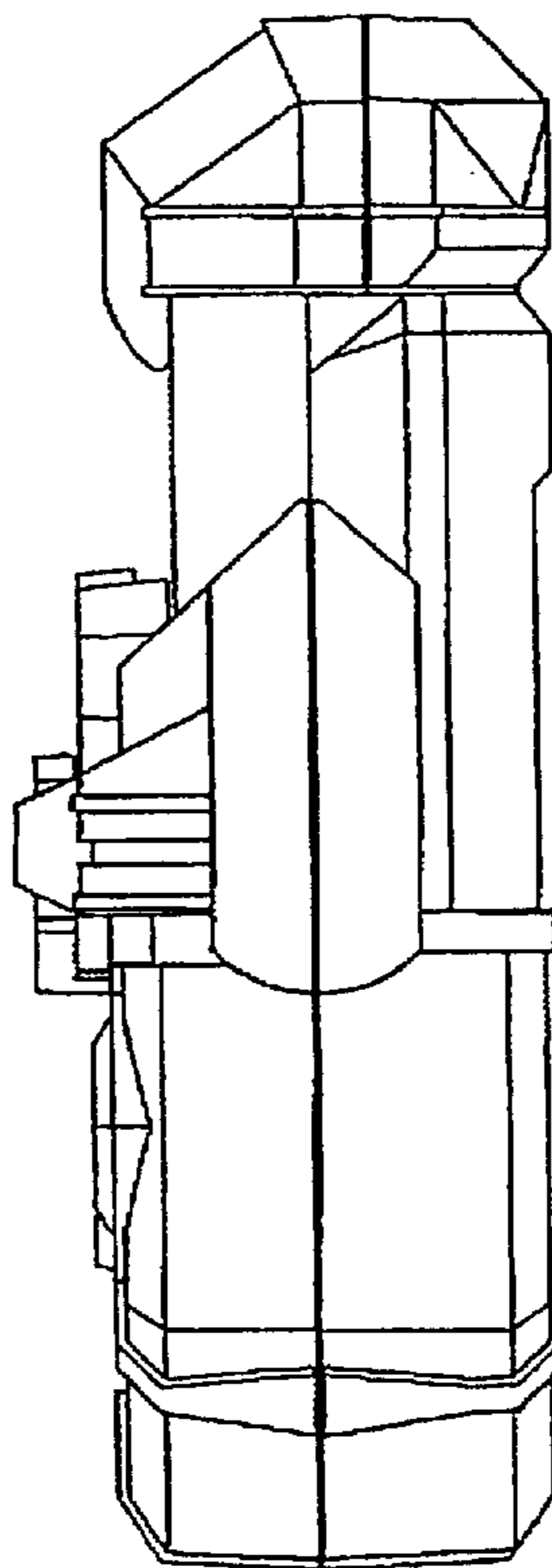

FIG. 5

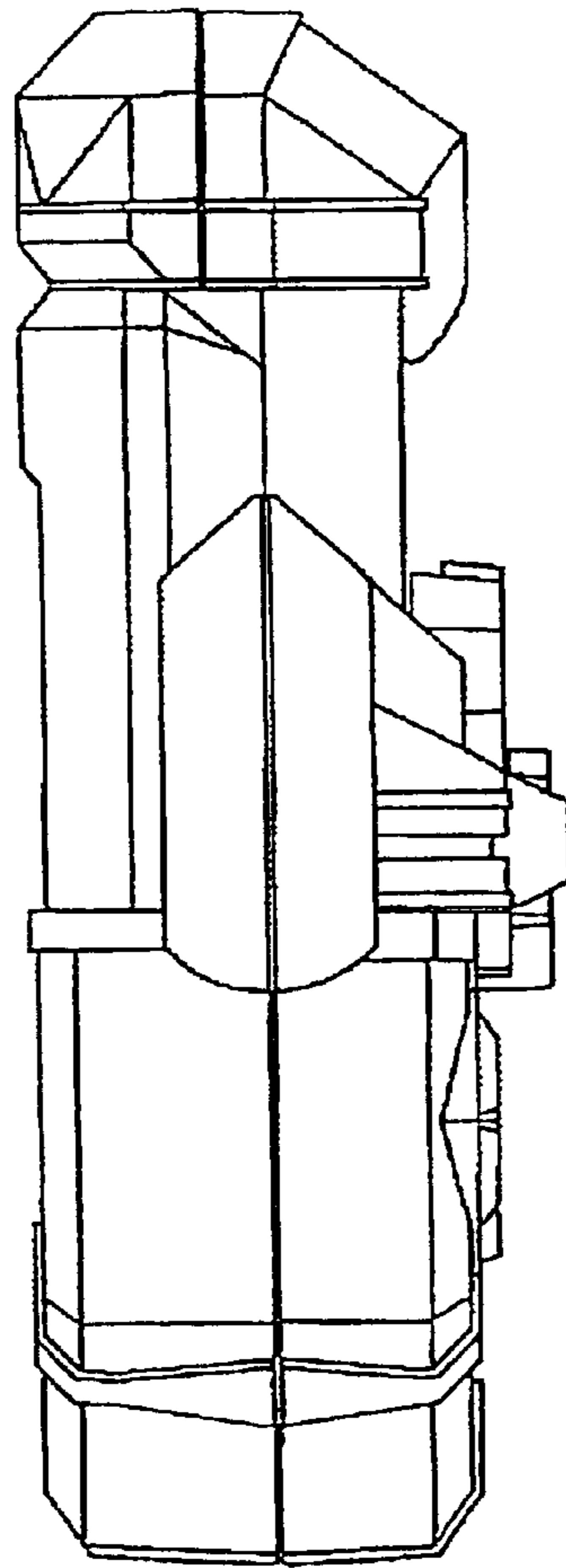

FIG. 6

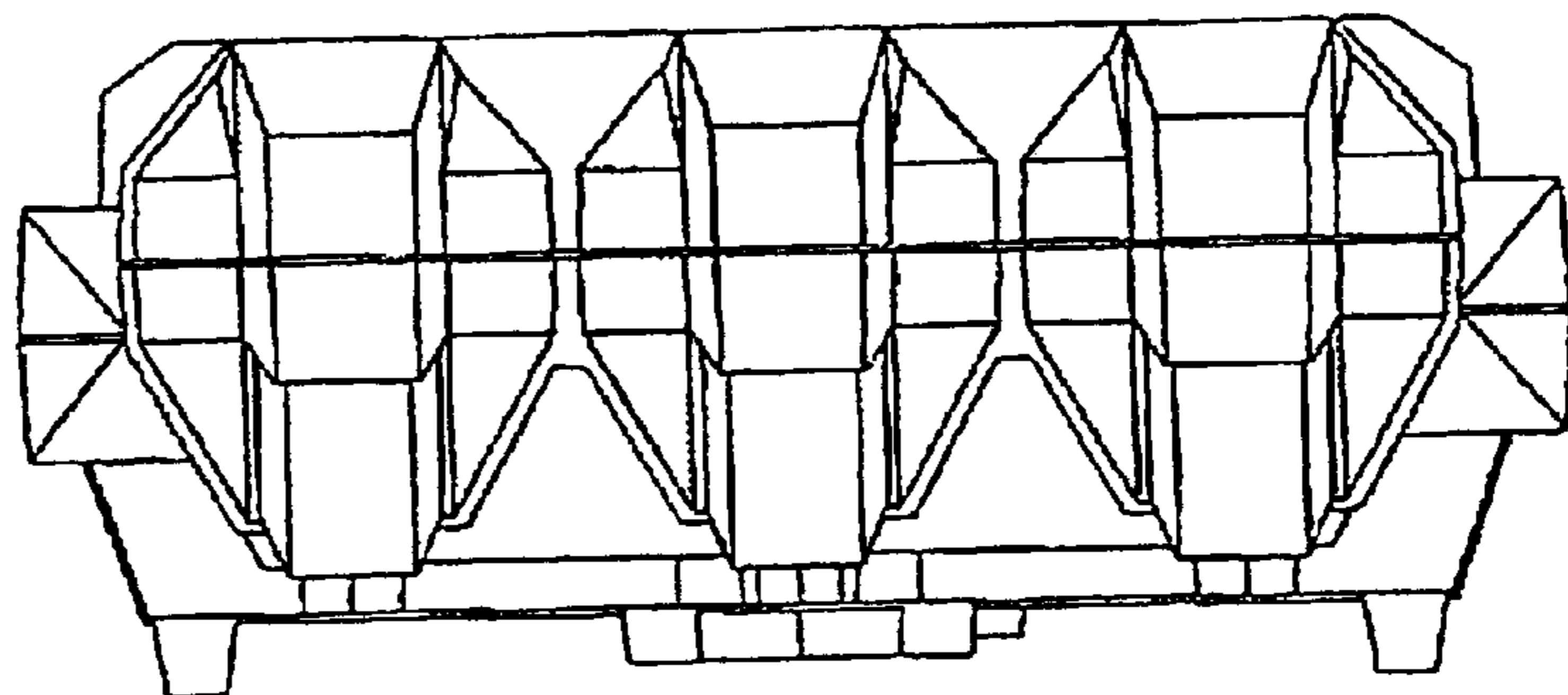

FIG. 7

