

US00D522440S

(12) **United States Design Patent**
Brooks et al.

(10) **Patent No.:** **US D522,440 S**
(45) **Date of Patent:** **** *Jun. 6, 2006**

(54) **MULTI-FUNCTION CORVETTE**

(75) Inventors: **James P. Brooks**, Gautier, MS (US);
Ross L. Buck, Mobile, AL (US);
Harold L. Galloway, Ocean Springs,
MS (US); **John P. Hackett**, Ocean
Springs, MS (US); **Kenneth E.**
Hoffman, Gautier, MS (US); **Kermit B.**
Pethtel, Jr., Ocean Springs, MS (US);
John F. Robbins, II, Gulfport, MS
(US); **Richard F. Sandifer, Jr.**,
Sanoma, CA (US); **William J.**
Steelman, Ocean Springs, MS (US);
Peter K. Weinrich, Ocean Springs, MS
(US)

(73) Assignee: **Ingalls Shipbuilding, Inc.**, Pascagoula,
MS (US)

(*) Notice: This patent is subject to a terminal dis-
claimer.

(**) Term: **14 Years**

(21) Appl. No.: **29/074,331**

(22) Filed: **Aug. 4, 1997**

(51) **LOC (8) Cl.** **12-06**

(52) **U.S. Cl.** **D12/300; D12/315**

(58) **Field of Classification Search** D12/300-318;
114/1, 258, 259, 72, 56, 57, 61, 67 A; 440/66,
440/67

See application file for complete search history.

(56) **References Cited**

U.S. PATENT DOCUMENTS

4,550,673 A	*	11/1985	Ingvason	114/56
5,176,094 A	*	1/1993	Gongwer	114/61
D366,642 S	*	1/1996	Brooks et al.	D12/315

* cited by examiner

Primary Examiner—Kay H. Chin

(74) *Attorney, Agent, or Firm*—Scott J. Coonan, Esq.

(57) **CLAIM**

The ornamental design for a multi-function corvette, as shown and described.

DESCRIPTION

FIG. 1 is a front perspective view of a multi-function corvette showing our new design, the broken lines are for illustrative purposes only and form no part of the claimed design;

FIG. 2 is a front elevational view thereof;

FIG. 3 is a rear elevational view thereof;

FIG. 4 is a side elevational view thereof, the opposite side view being a mirror image of that shown;

FIG. 5 is a top plan view thereof; and,

FIG. 6 is a bottom plan view thereof.

1 Claim, 2 Drawing Sheets

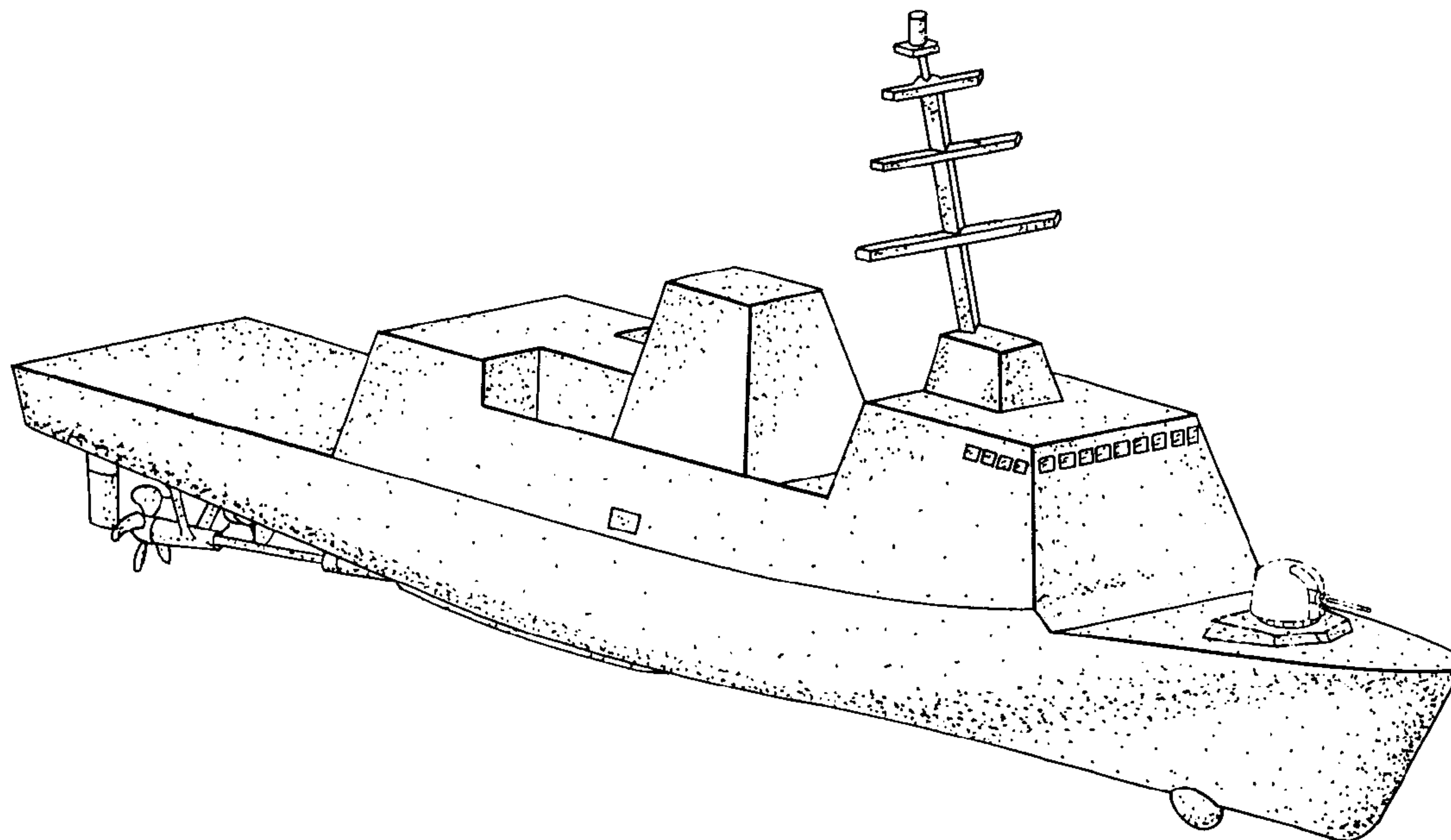

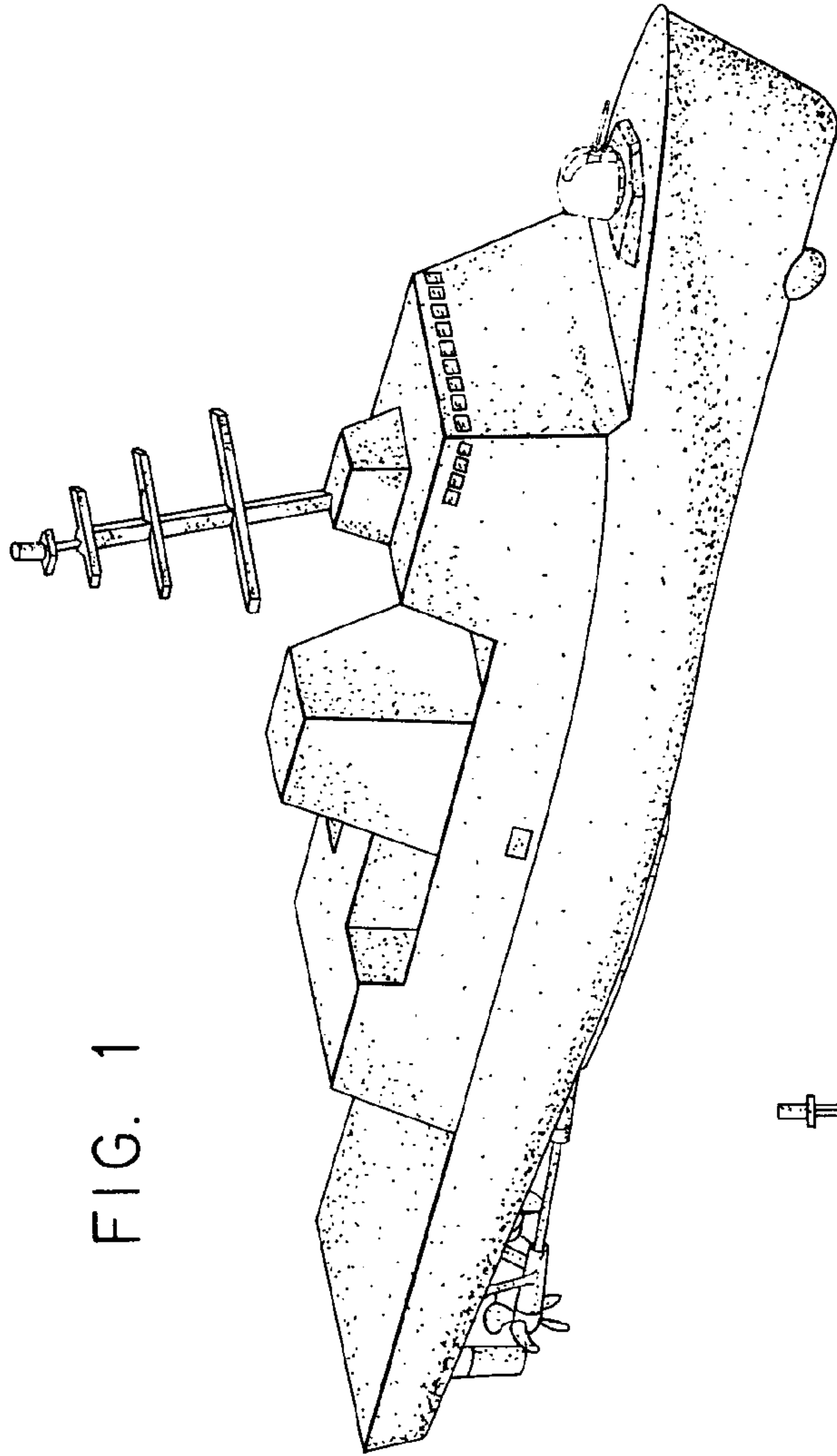

FIG. 1

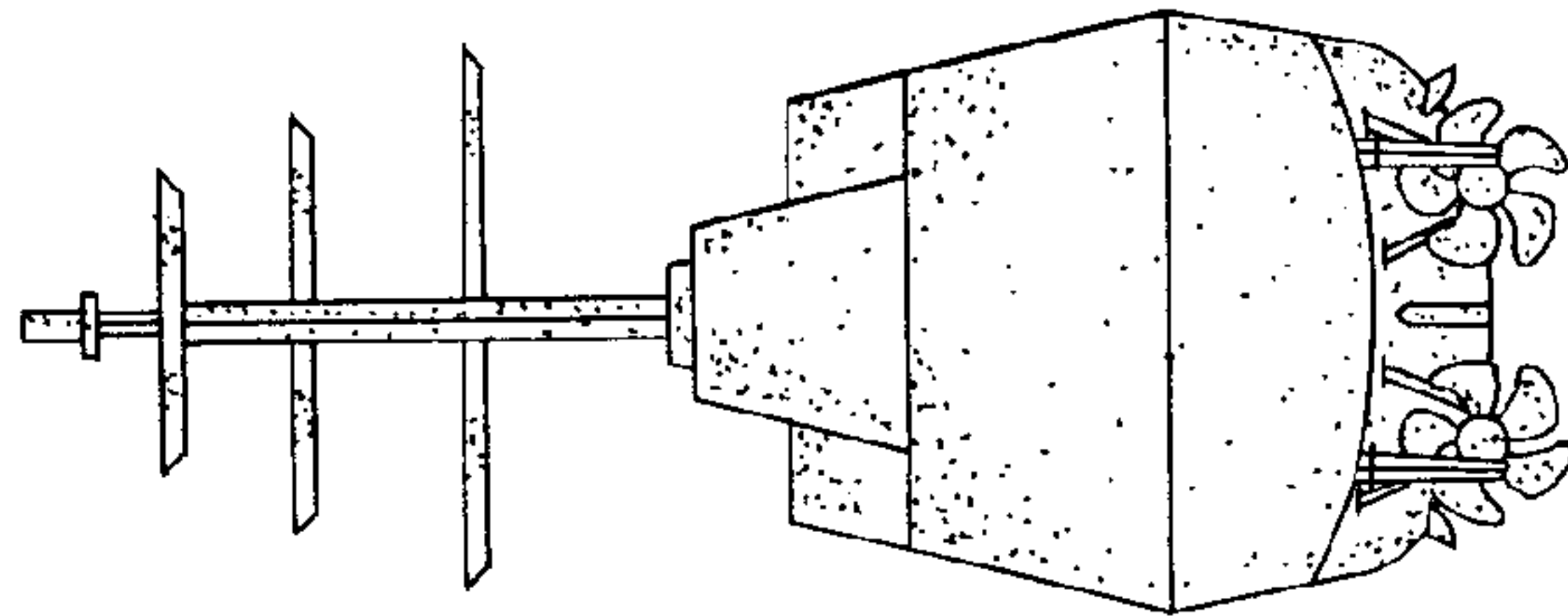

FIG. 3

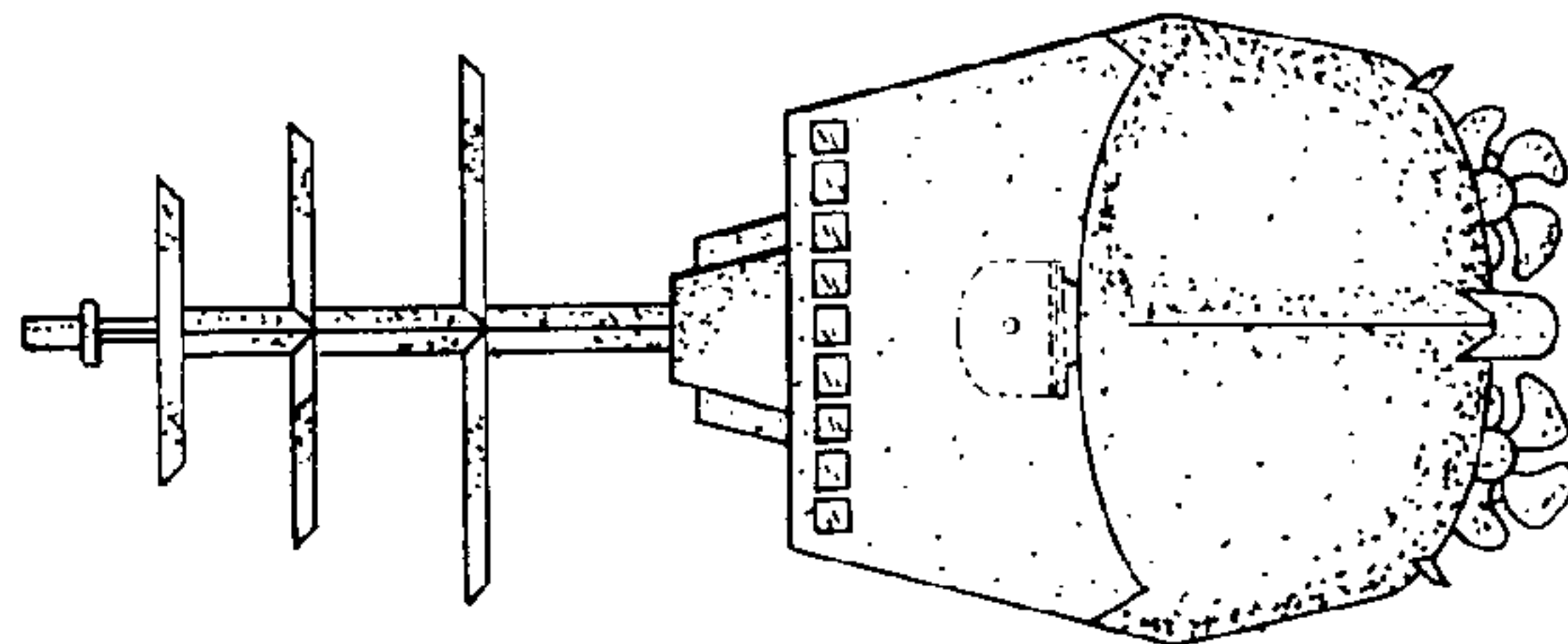

FIG. 2

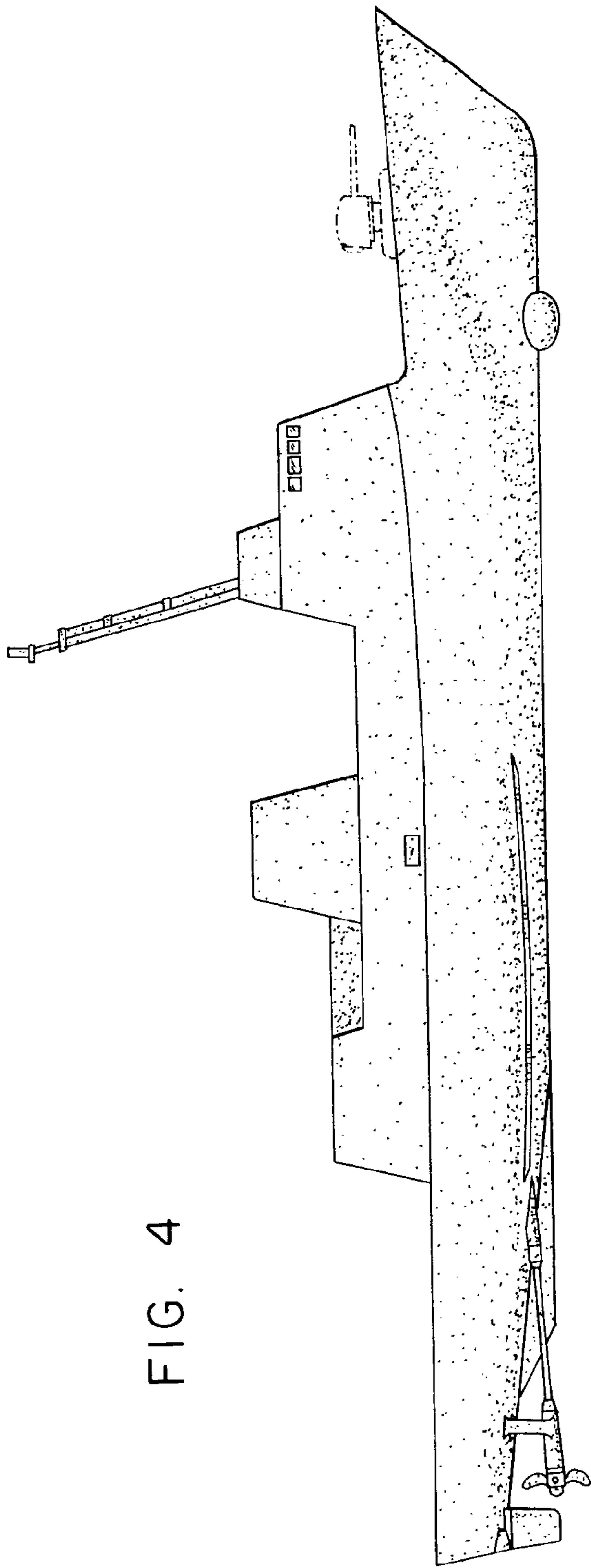

FIG. 4

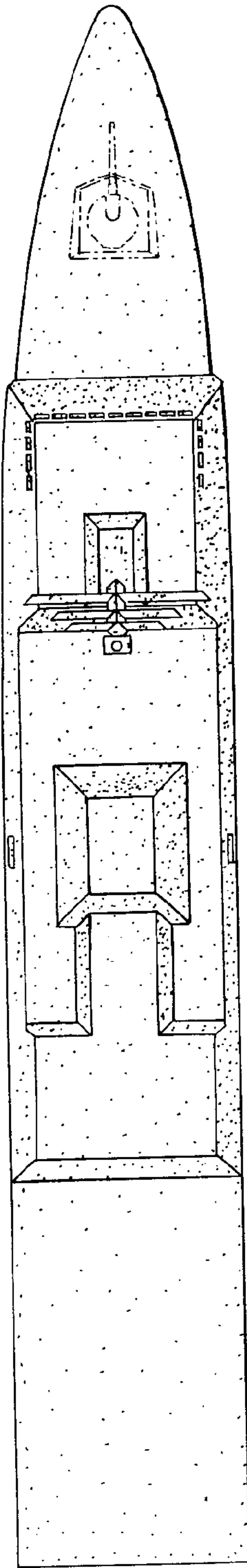

FIG. 5

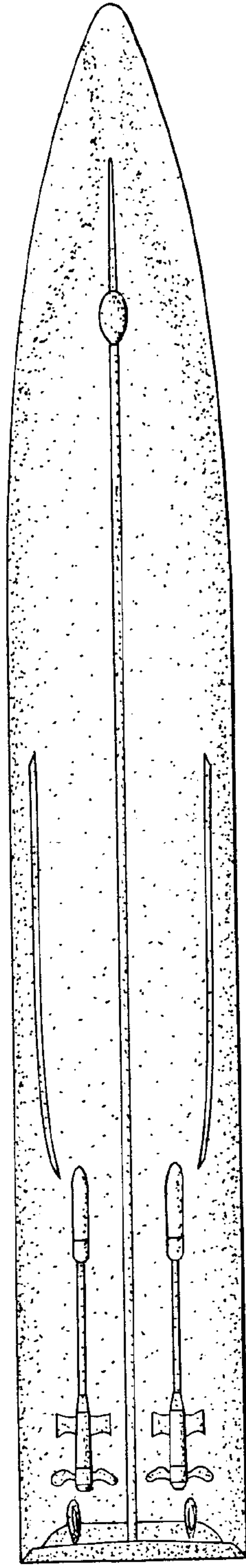

FIG. 6