



US00D522417S

(12) **United States Design Patent**
Akamine et al.

(10) **Patent No.:** **US D522,417 S**
(45) **Date of Patent:** **** Jun. 6, 2006**

(54) **FRONT BUMPER FOR AUTOMOBILE**

(75) Inventors: **Shuzo Akamine**, Aichi-ken (JP); **Ryuji Yoshinaga**, Aichi-ken (JP); **Naoto Furukado**, Aichi-ken (JP)

(73) Assignee: **Toyota Jidosha Kabushiki Kaisha**, Aichi-ken (JP)

(**) Term: **14 Years**

(21) Appl. No.: **29/228,314**

(22) Filed: **Apr. 22, 2005**

(51) **LOC (8) Cl.** **12-16**

(52) **U.S. Cl.** **D12/169**

(58) **Field of Classification Search** D12/90-92,
D12/86, 169, 196, 163; 296/180.1, 180.2;
293/102, 113, 115, 117, 120

See application file for complete search history.

(56) **References Cited**

U.S. PATENT DOCUMENTS

D452,207 S	12/2001	Ishii et al.	
D499,362 S	12/2004	Minami et al.	
D499,675 S	* 12/2004	Sasaki et al.	D12/169
D499,676 S	* 12/2004	Chan	D12/169
D502,899 S	* 3/2005	Mino et al.	D12/169
D510,304 S	* 10/2005	Tabata et al.	D12/169

OTHER PUBLICATIONS

Home page of Honda Motor Co. Ltd, Photographs of Honda Stream (2 photos).

Home page of Daimler Chrysler Japan, Photograph of Chrysler Town & Country (1 photo).

* cited by examiner

Primary Examiner—Melody N. Brown

(74) *Attorney, Agent, or Firm*—Finnegan, Henderson, Farabow, Garrett & Dunner, LLP

(57) **CLAIM**

The ornamental design for a front bumper for automobile, as shown and described.

DESCRIPTION

FIG. 1 is a left-front, perspective view of a front bumper for automobile of our new design;

FIG. 2 is a front view of our new design;

FIG. 3 is a rear view of our new design;

FIG. 4 is a top view of our new design;

FIG. 5 is a bottom view of our new design;

FIG. 6 is a left-side view our new design, the right-side view being a mirror image thereof;

FIG. 7 is a cross-sectional view of our new design taken along the line 7—7 in FIG. 2, showing the profile of that portion of the design;

FIG. 8 is a cross-sectional view of our new design taken along the line 8—8 in FIG. 2, showing the profile of that portion of the design; and,

FIG. 9 is a cross-sectional view of our new design taken along the line 9—9 in FIG. 2, showing the profile of that portion of the design.

1 Claim, 5 Drawing Sheets

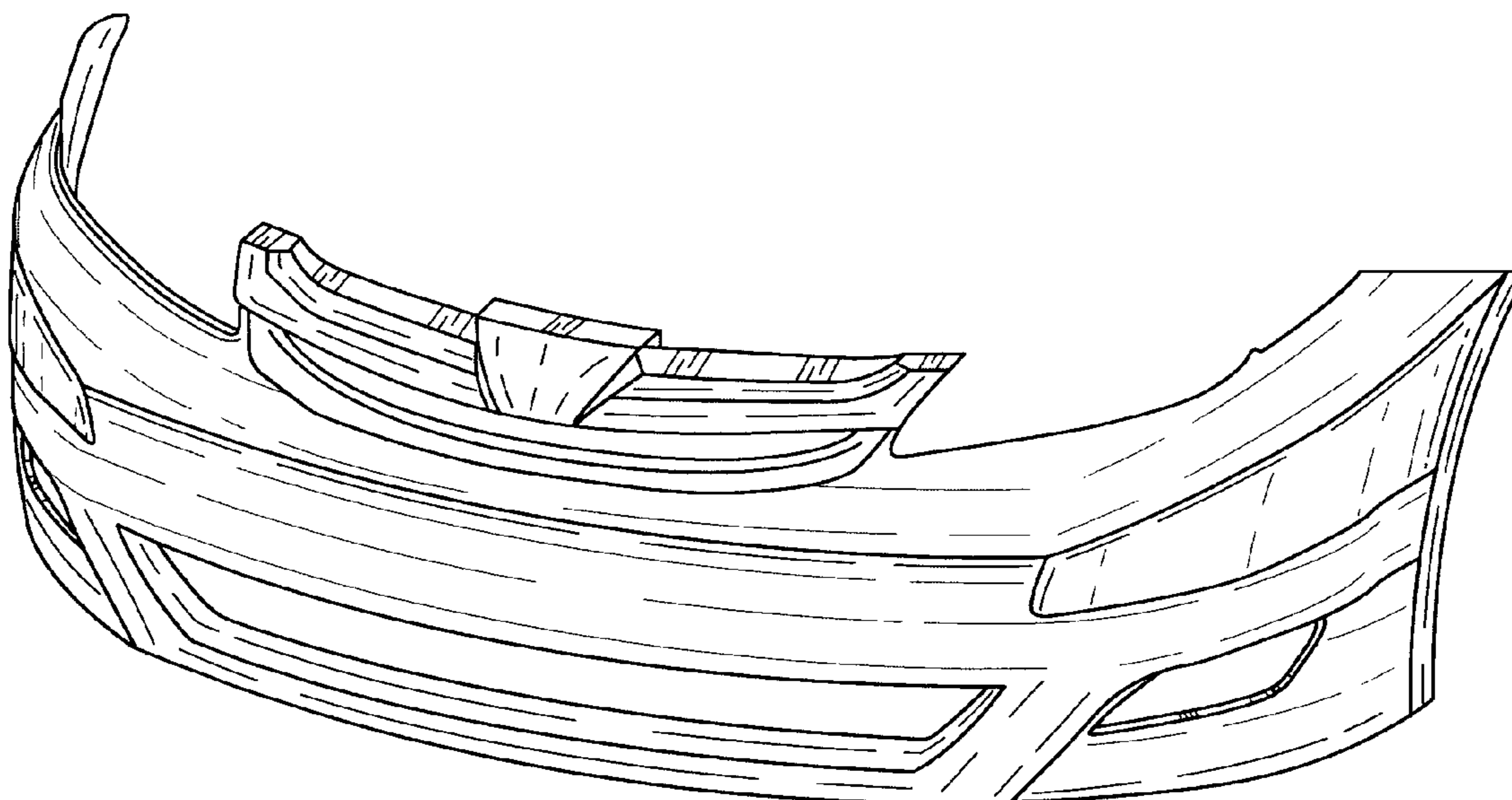

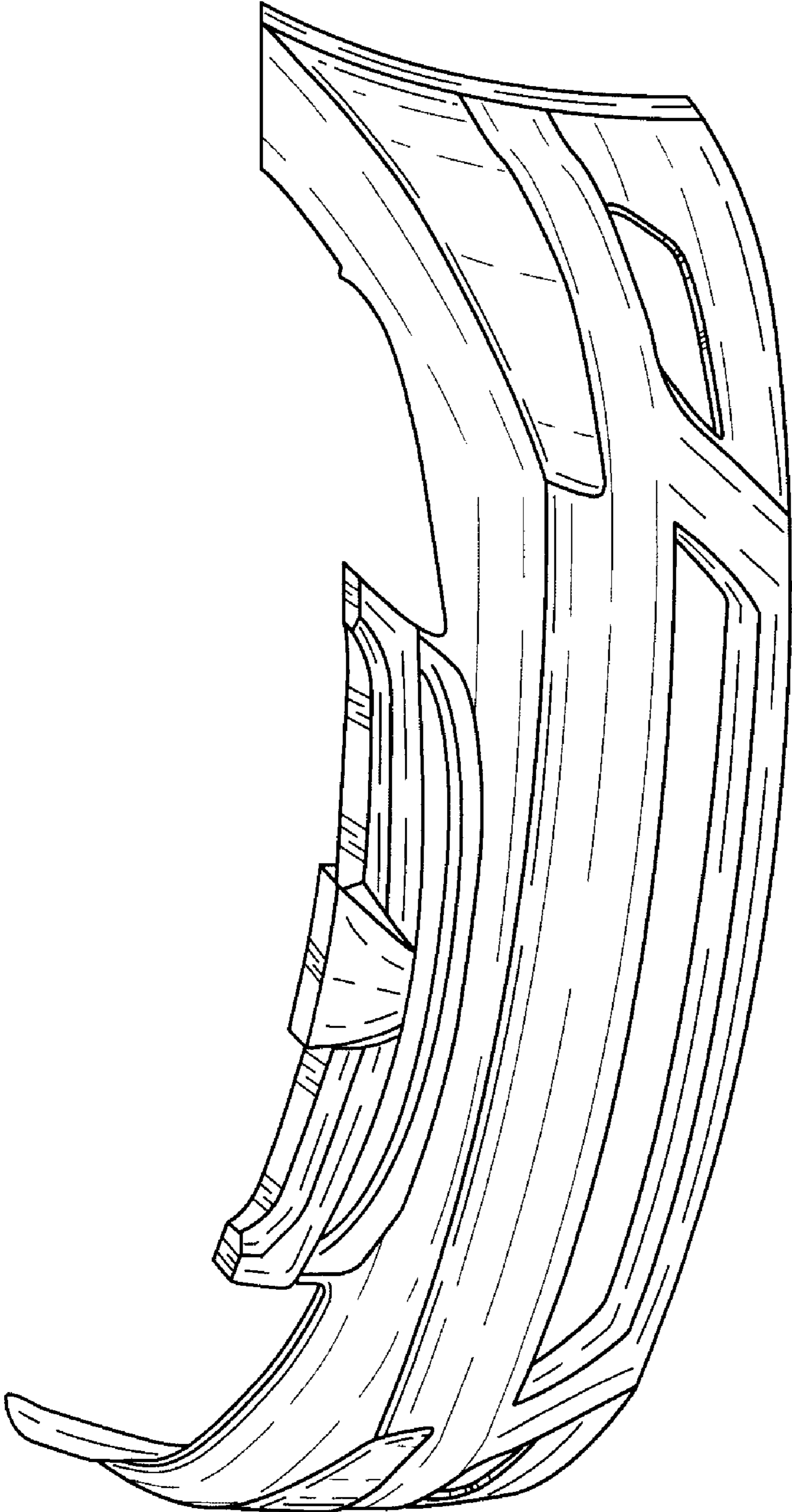

FIG. 1

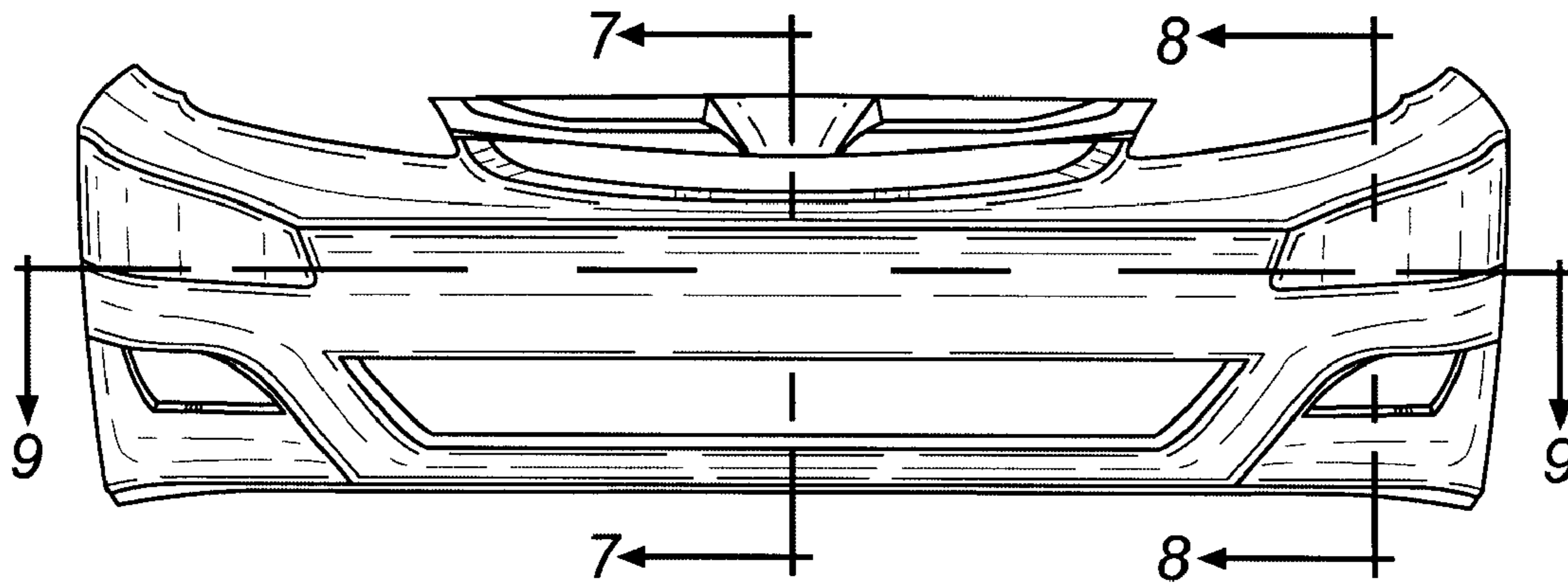

FIG. 2

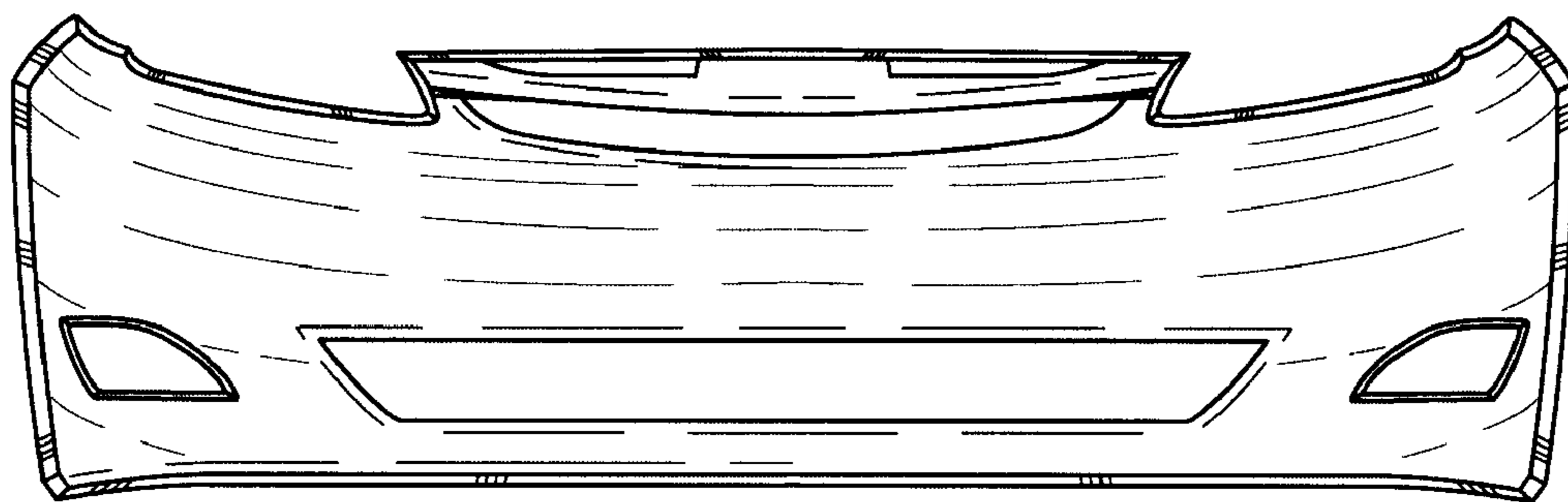

FIG. 3

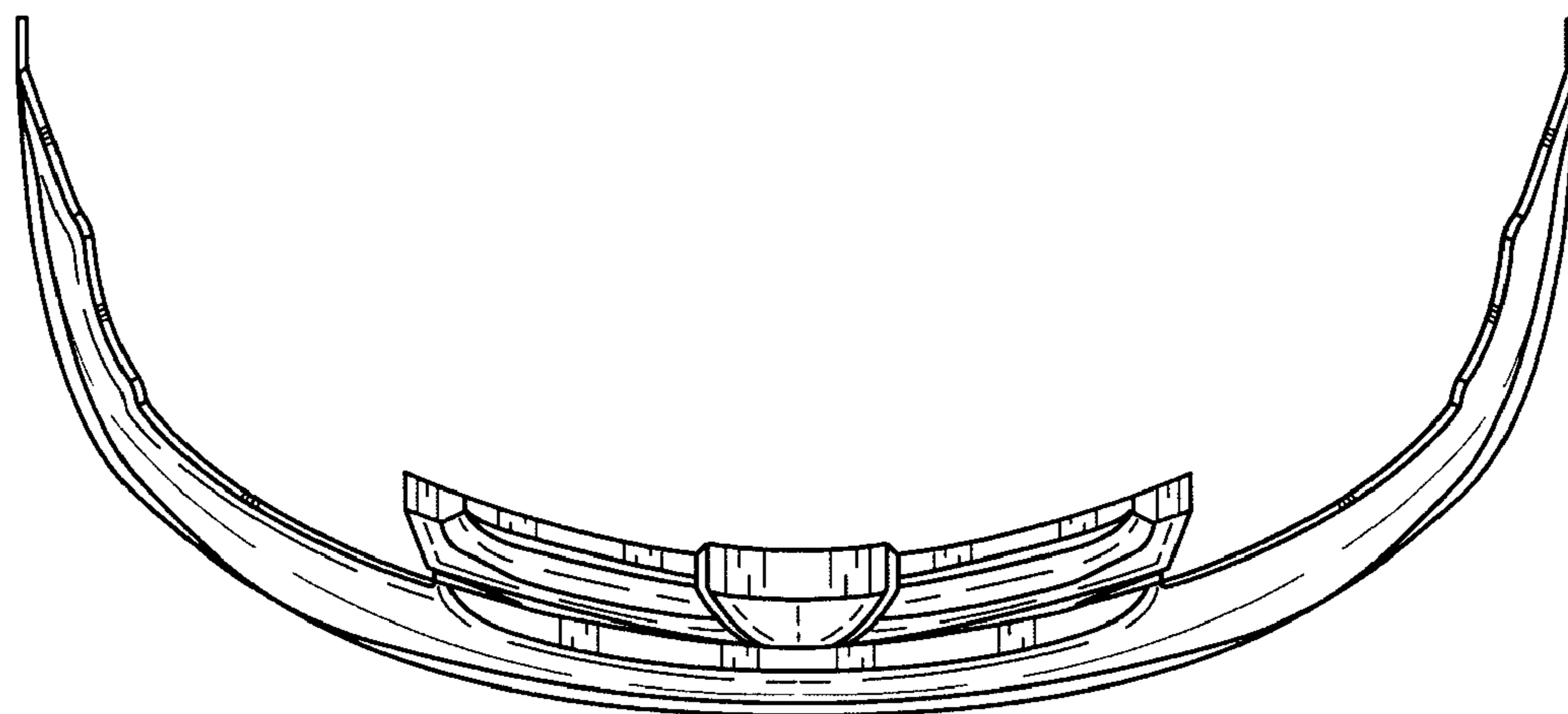

FIG. 4

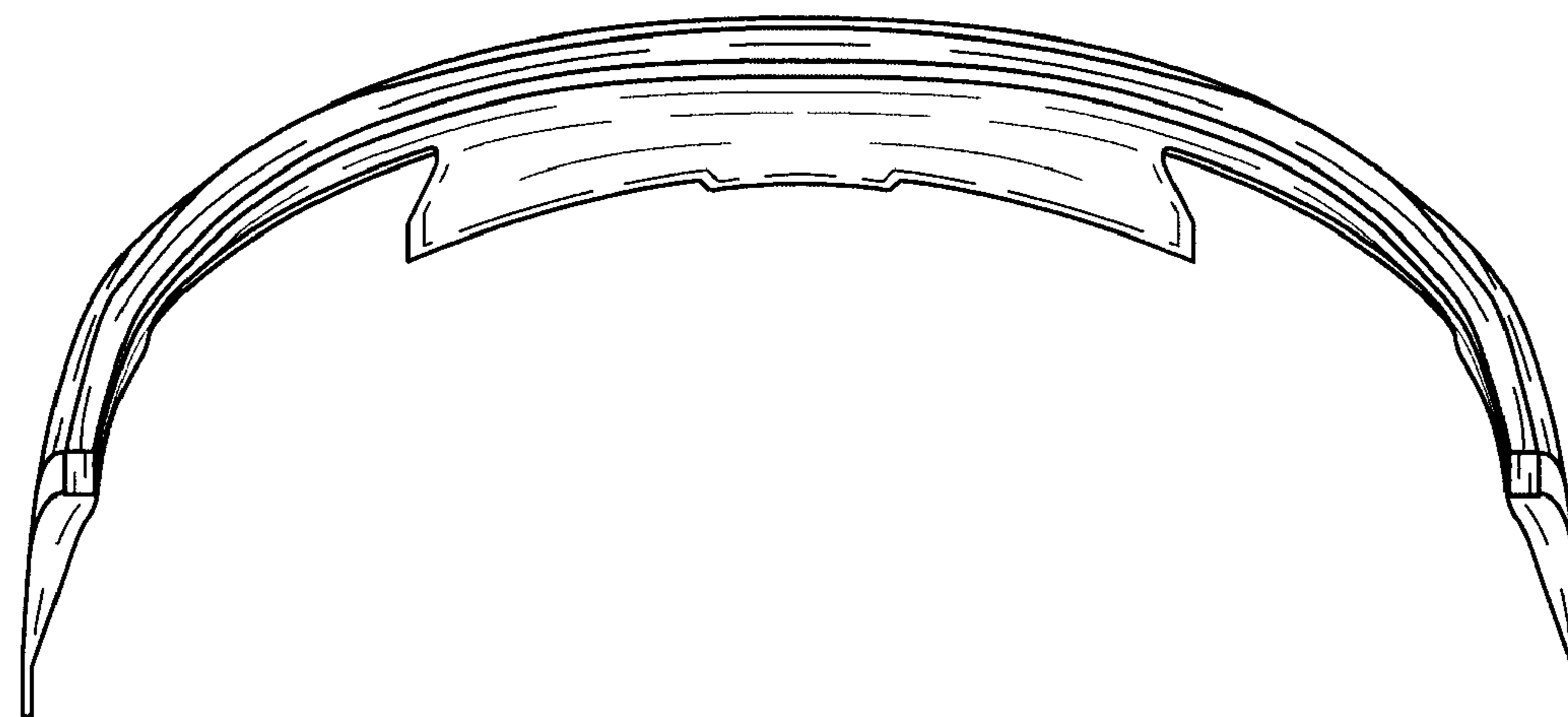

FIG. 5

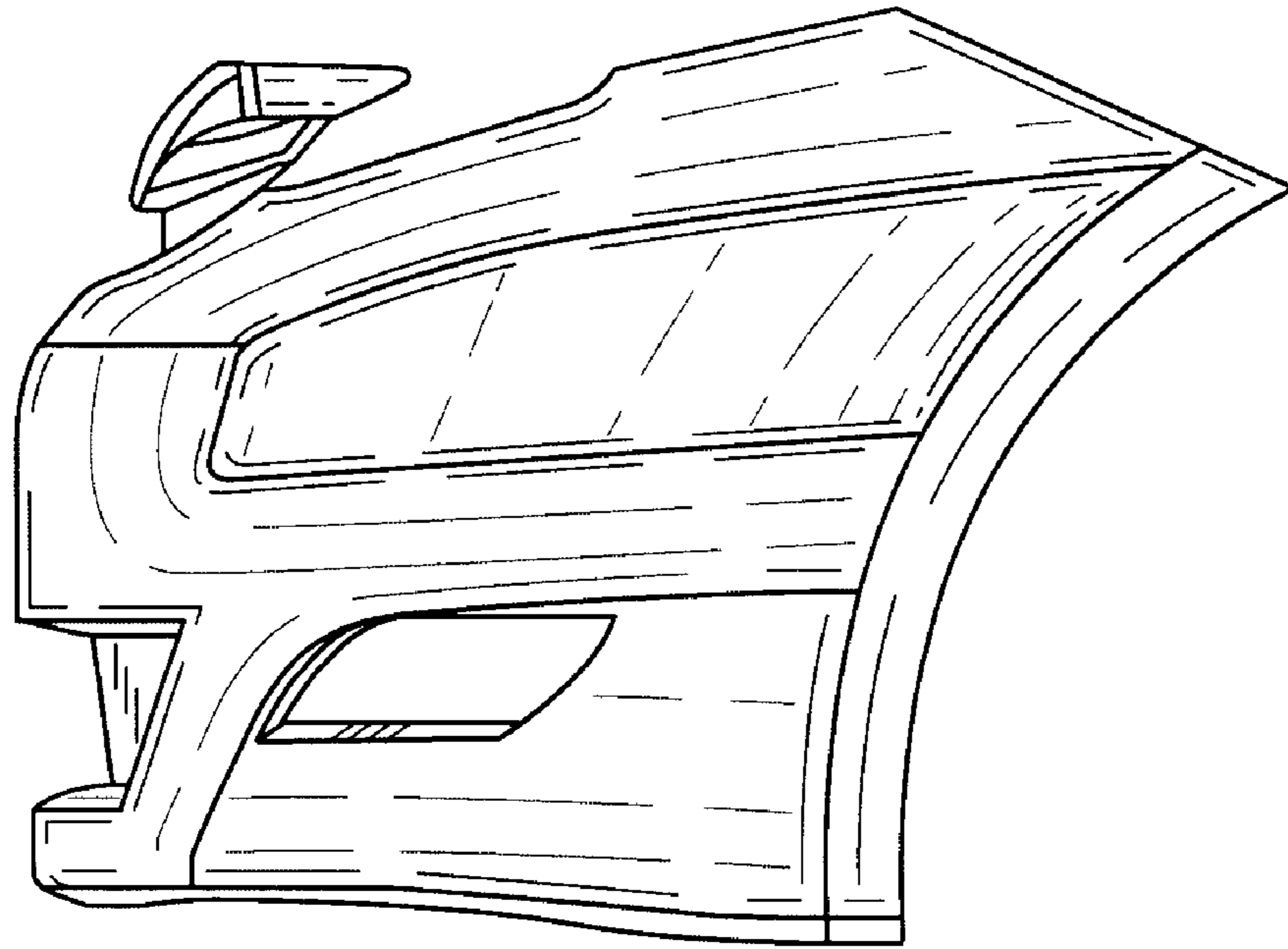

FIG. 6

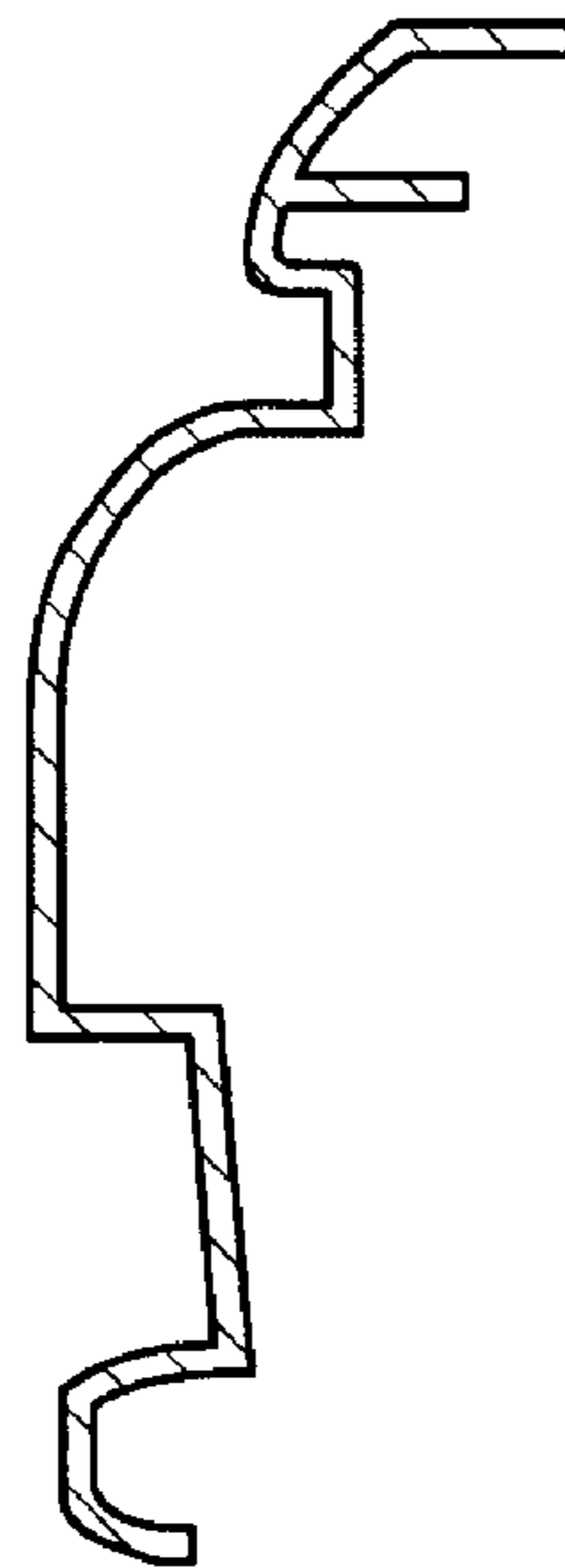

FIG. 7

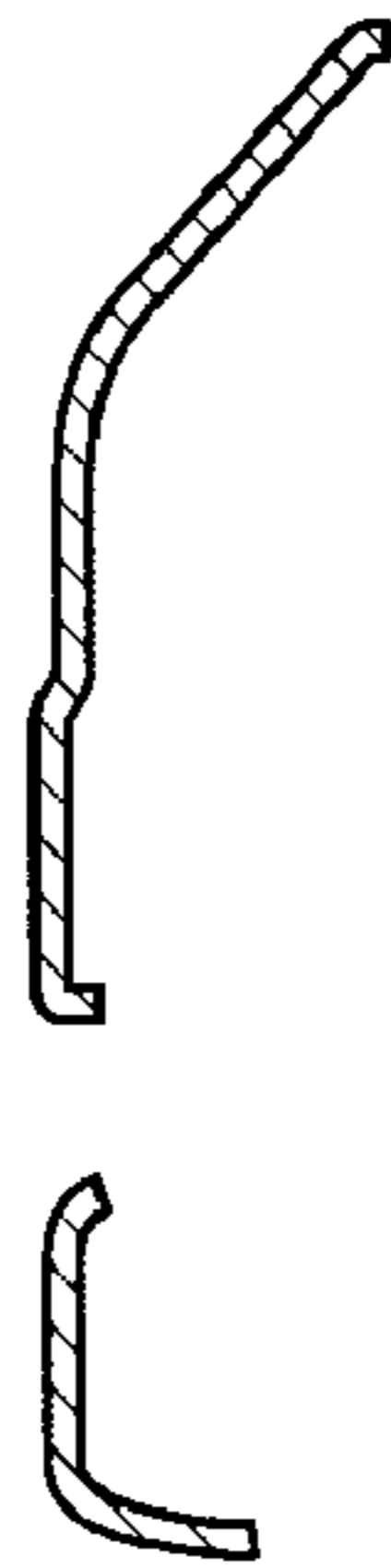

FIG. 8

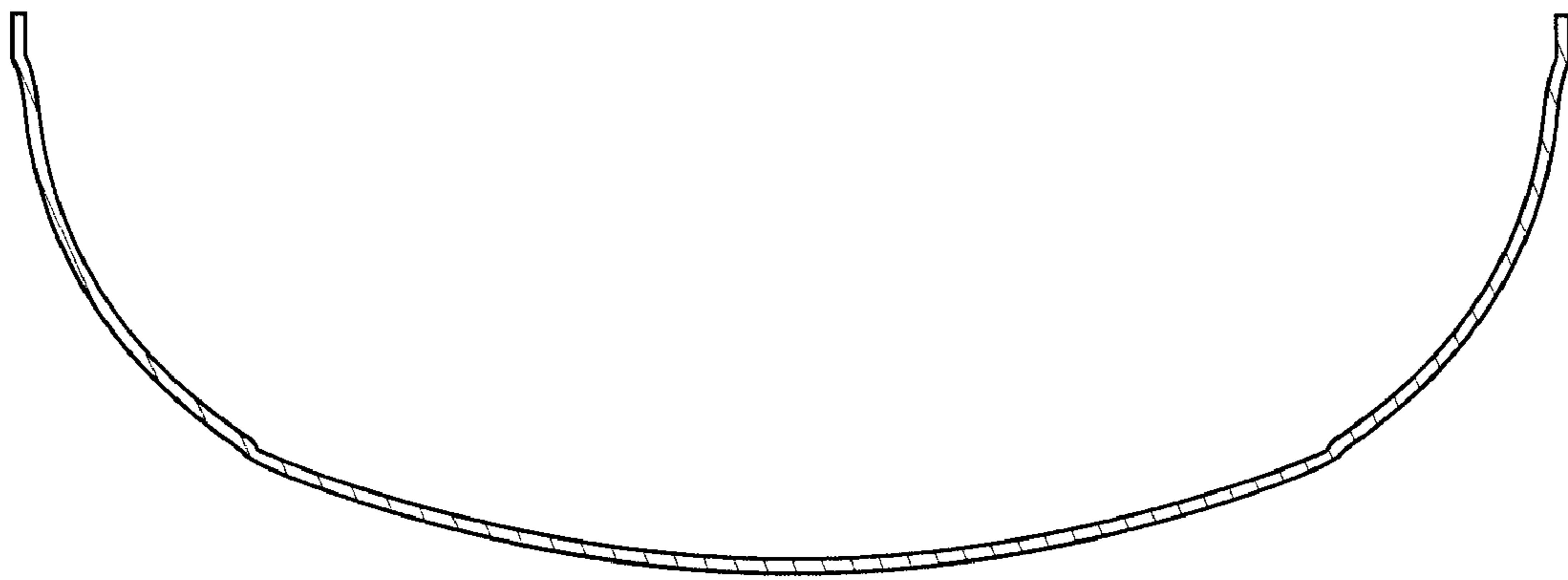

FIG. 9