



US00D522160S

(12) **United States Design Patent**
Sapper

(10) **Patent No.:** **US D522,160 S**
(45) **Date of Patent:** **** May 30, 2006**

(54) **LIGHT GENERATING APPARATUS**

(75) Inventor: **Richard Sapper**, Stuttgart (DE)

(73) Assignee: **Camaco AG**, Zurich (CH)

(**) Term: **14 Years**

(21) Appl. No.: **29/218,612**

(22) Filed: **Dec. 3, 2004**

(51) **LOC (8) Cl.** **26-05**

(52) **U.S. Cl.** **D26/65; D26/63**

(58) **Field of Classification Search** D26/60–65,
D26/93, 118, 107, 43, 51, 56; 362/269, 277,
362/278, 282, 285, 287, 288, 410, 413, 418–430,
362/449

See application file for complete search history.

(56) **References Cited**

U.S. PATENT DOCUMENTS

3,345,024 A * 10/1967 Victor D26/61
D225,890 S * 1/1973 Entwistle D26/65

(Continued)

OTHER PUBLICATIONS

Marisa Bartolucci, “*Let there be L.E.D.*”, *The New York Times Style Magazine*, Spring 2005, 4 pages.

Peter Hall, “*Desktop Comet*”, *Metropolis—Architecture<Culture> Design*, Apr. 2005, 10 pages.

Cecilia Fabiani, “*OLIVARI: Richard Sapper . . . designers: technically complex products with a capacity to communicate . . .*”, *OLIVARI Concept by Think*, 1998–2000, 4 pages.

Artemide, “*Select the Tizio of your choice*”, http://www.artemidestore.com/?page=1_tiziomodelselection/index Oct. 11, 2004, 1 page.

Primary Examiner—Clare E Heflin

(74) *Attorney, Agent, or Firm*—Blakely, Sokoloff, Taylor & Zafman LLP

(57) **CLAIM**

The ornamental design for a light generating apparatus, as shown and described.

DESCRIPTION

FIG. 1 is a left side view of a first embodiment of my new design wherein the light generating apparatus is configured as a desk lamp;

FIG. 2 is a right side view thereof;

FIG. 3 is a top view thereof;

FIG. 4 is a bottom view thereof;

FIG. 5 is a back view thereof;

FIG. 6 is a front view thereof;

FIG. 7 is a left front perspective view thereof;

FIG. 8 is a back perspective view thereof;

FIG. 9 is a left side view thereof, showing my new design in a first alternate position;

FIG. 10 is a right side view thereof;

FIG. 11 is a top view thereof;

FIG. 12 is a bottom view thereof;

FIG. 13 is a back view thereof;

FIG. 14 is a front view thereof;

FIG. 15 is a left front perspective view thereof;

FIG. 16 is a back perspective view thereof;

FIG. 17 is a left side view thereof, showing my new design in a second alternate position;

FIG. 18 is a right side view thereof;

FIG. 19 is a top view thereof;

FIG. 20 is a bottom view thereof;

FIG. 21 is a back view thereof;

FIG. 22 is a front view thereof;

FIG. 23 is a left front perspective view thereof;

FIG. 24 is a back perspective view thereof;

FIG. 25 is a left side view of a second embodiment of my new design wherein the light generating apparatus is configured as a floor lamp;

FIG. 26 is a right side view thereof;

FIG. 27 is a top view thereof;

FIG. 28 is a bottom view thereof;

FIG. 29 is a back view thereof;

FIG. 30 is a front view thereof; and,

FIG. 31 is a back perspective view thereof.

1 Claim, 22 Drawing Sheets

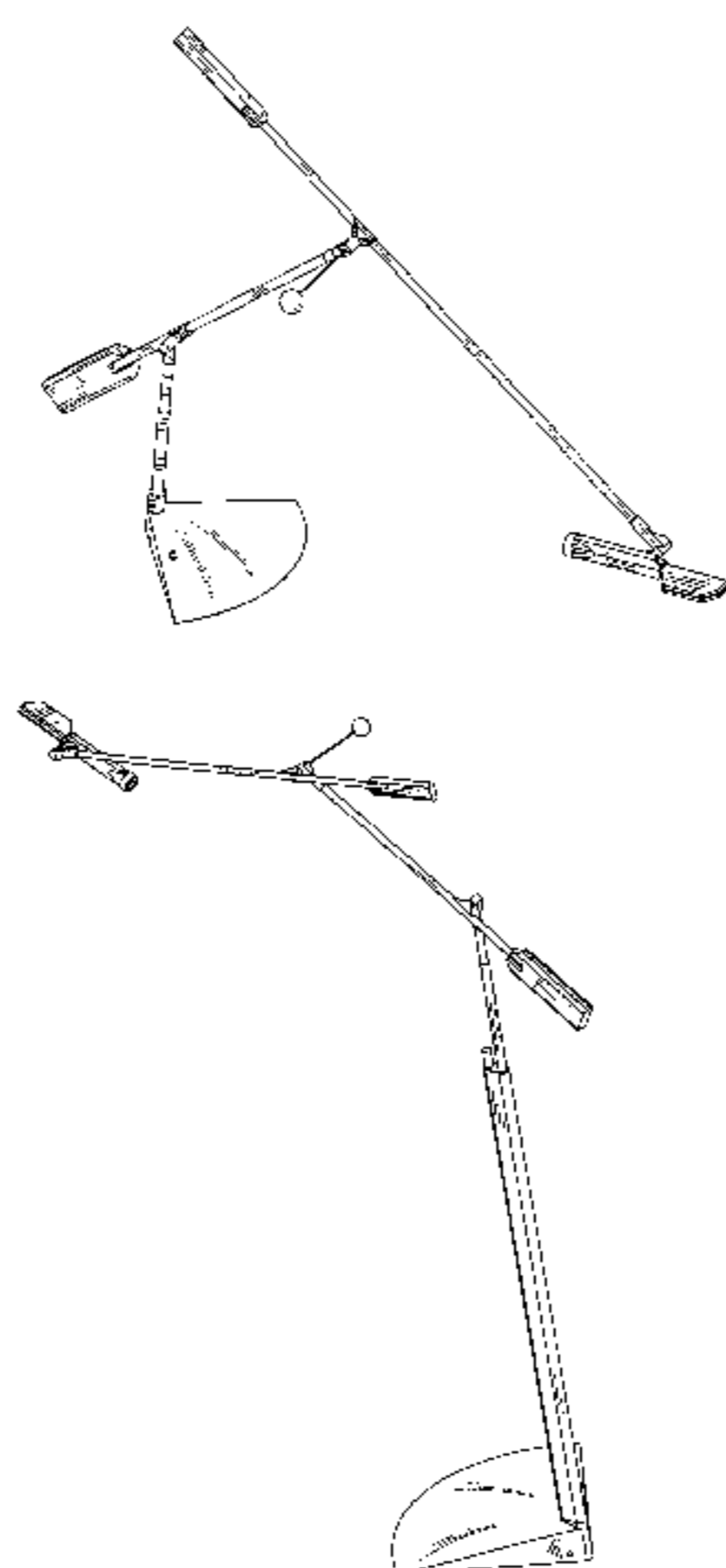

US D522,160 S

Page 2

U.S. PATENT DOCUMENTS			
3,790,773	A	2/1974	Sapper
4,494,177	A	1/1985	Matthews
4,772,993	A	9/1988	Engel
D318,535	S	* 7/1991	Von Klier D26/88
D326,533	S	* 5/1992	Cerbini D26/65
D330,266	S	* 10/1992	Lin D26/65
5,235,500	A	8/1993	Sapper
D393,732	S	* 4/1998	Rubenzer D26/65
6,394,634	B1	5/2002	Kitchin
D463,598	S	* 9/2002	Sonneman D26/65

* cited by examiner

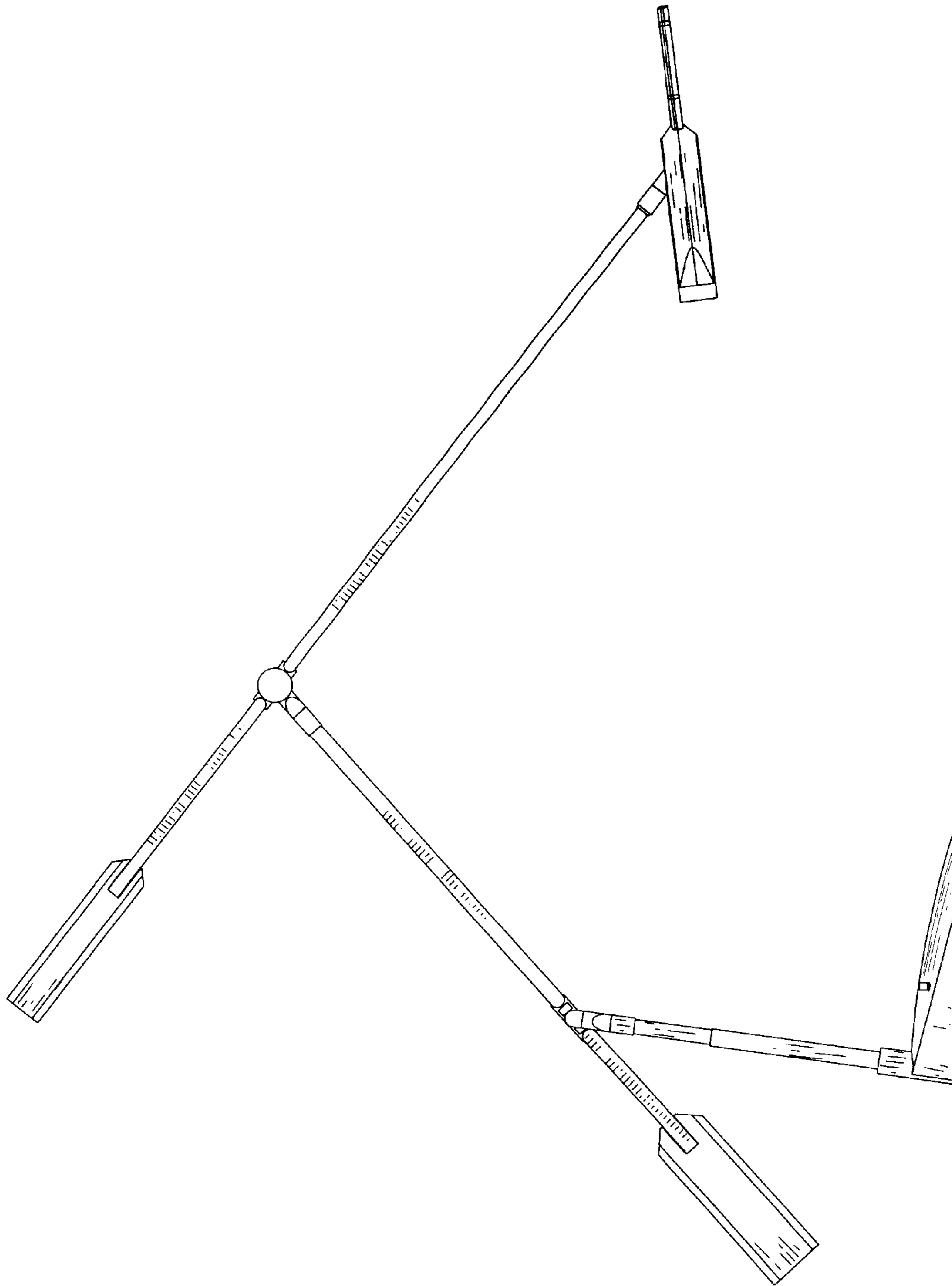

FIG. 1

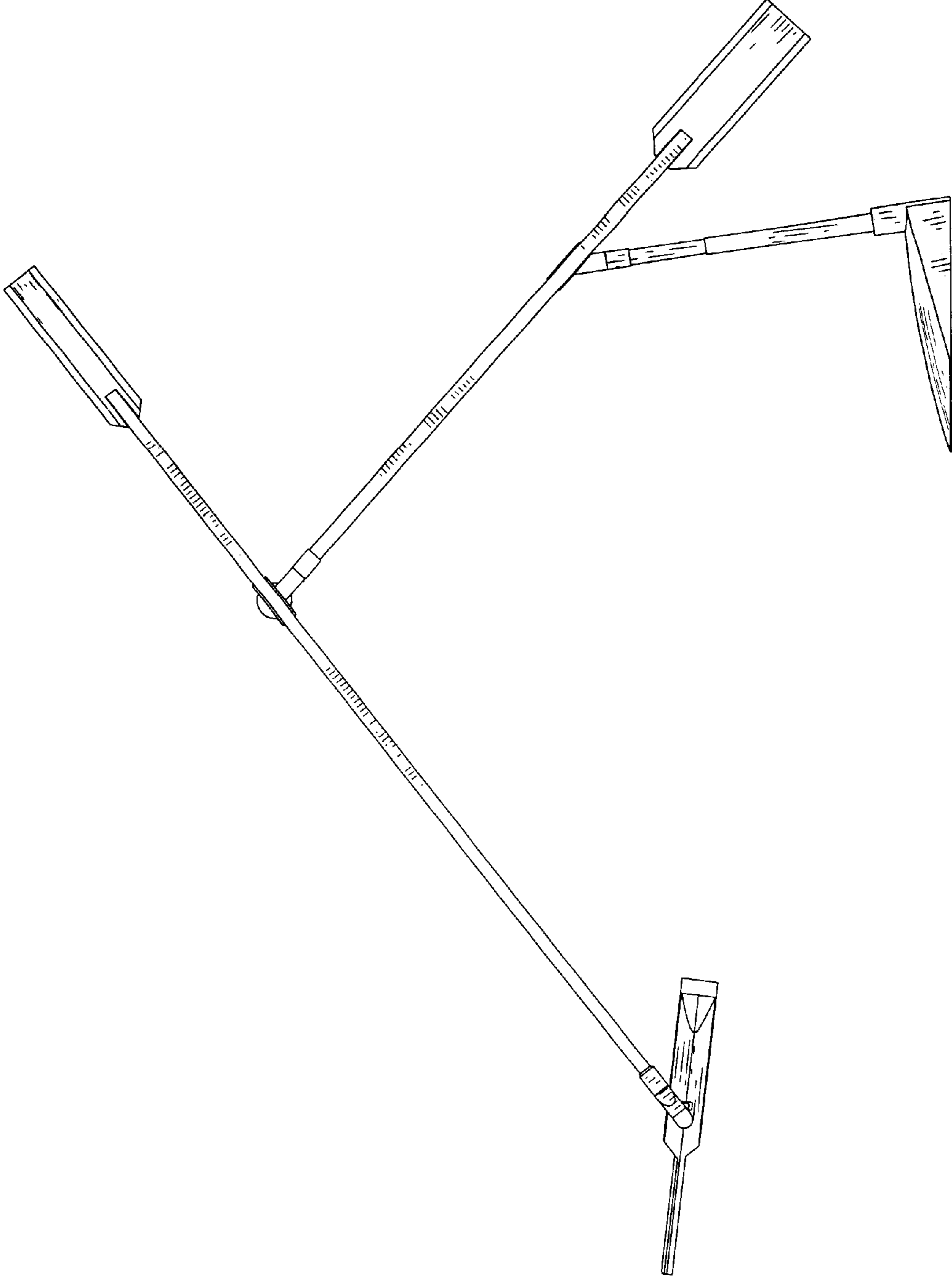

FIG. 2

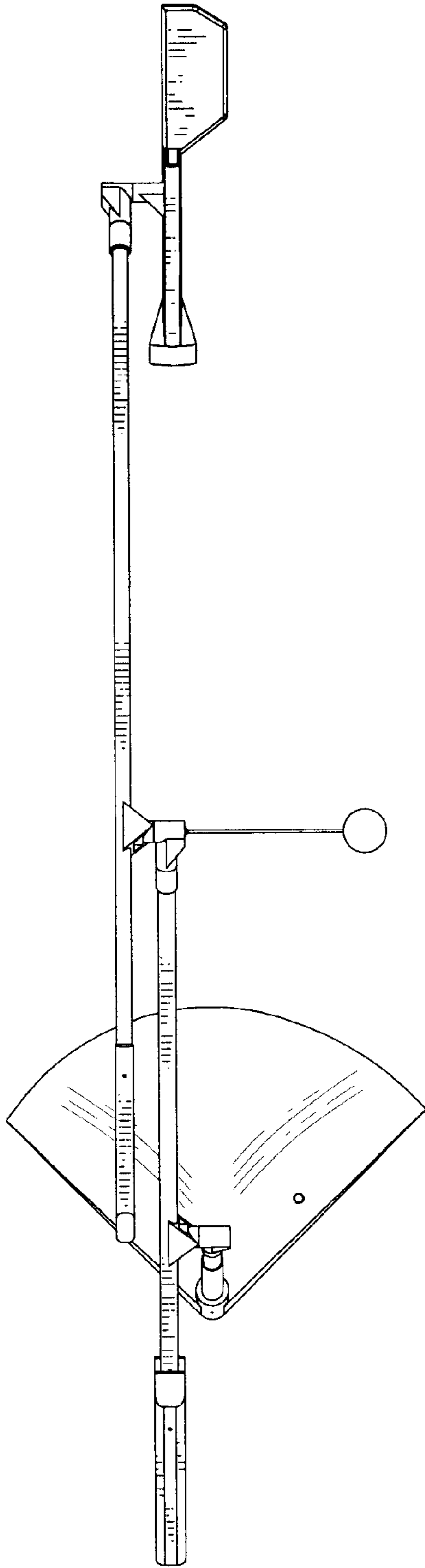

FIG. 3

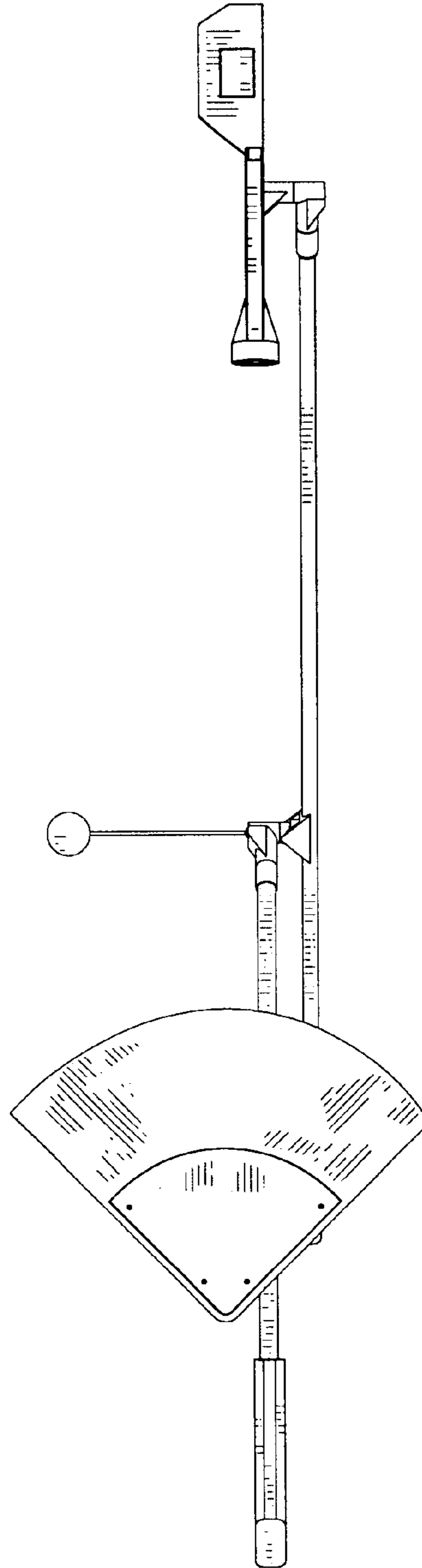

FIG. 4

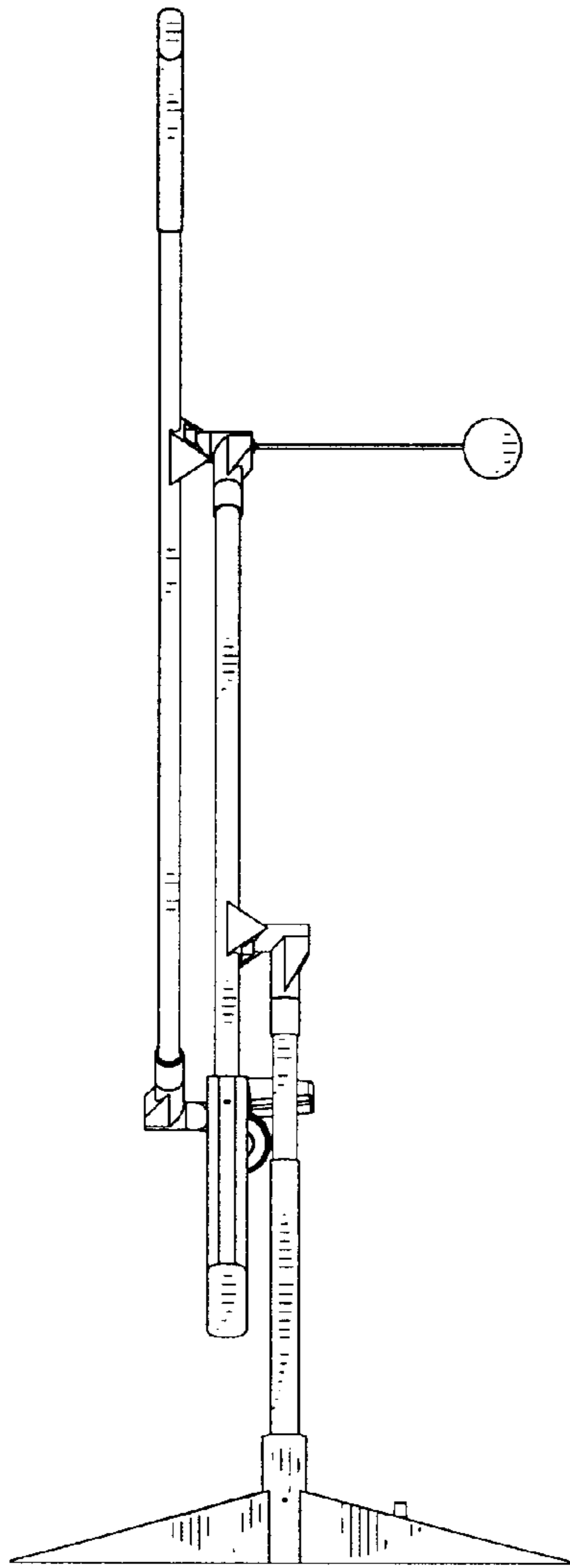

FIG. 5

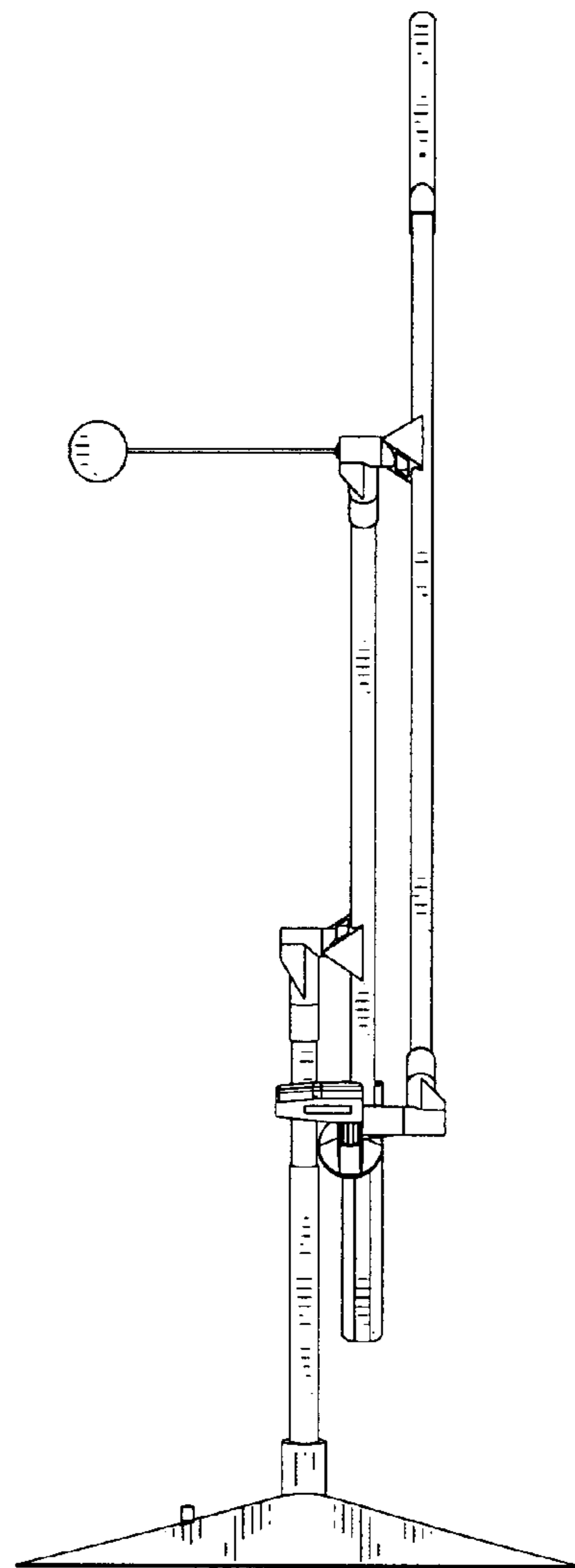

FIG. 6

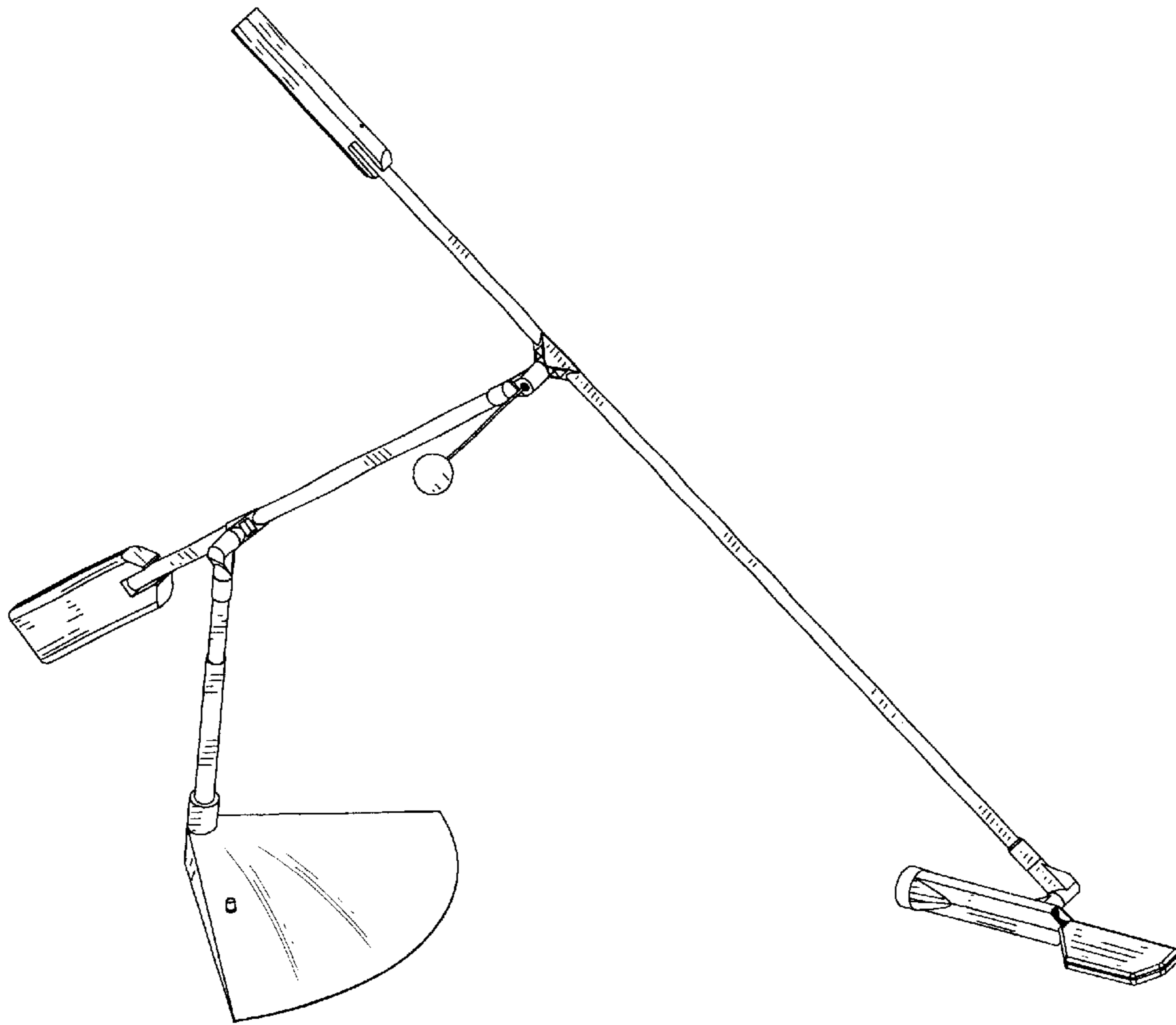

FIG. 7

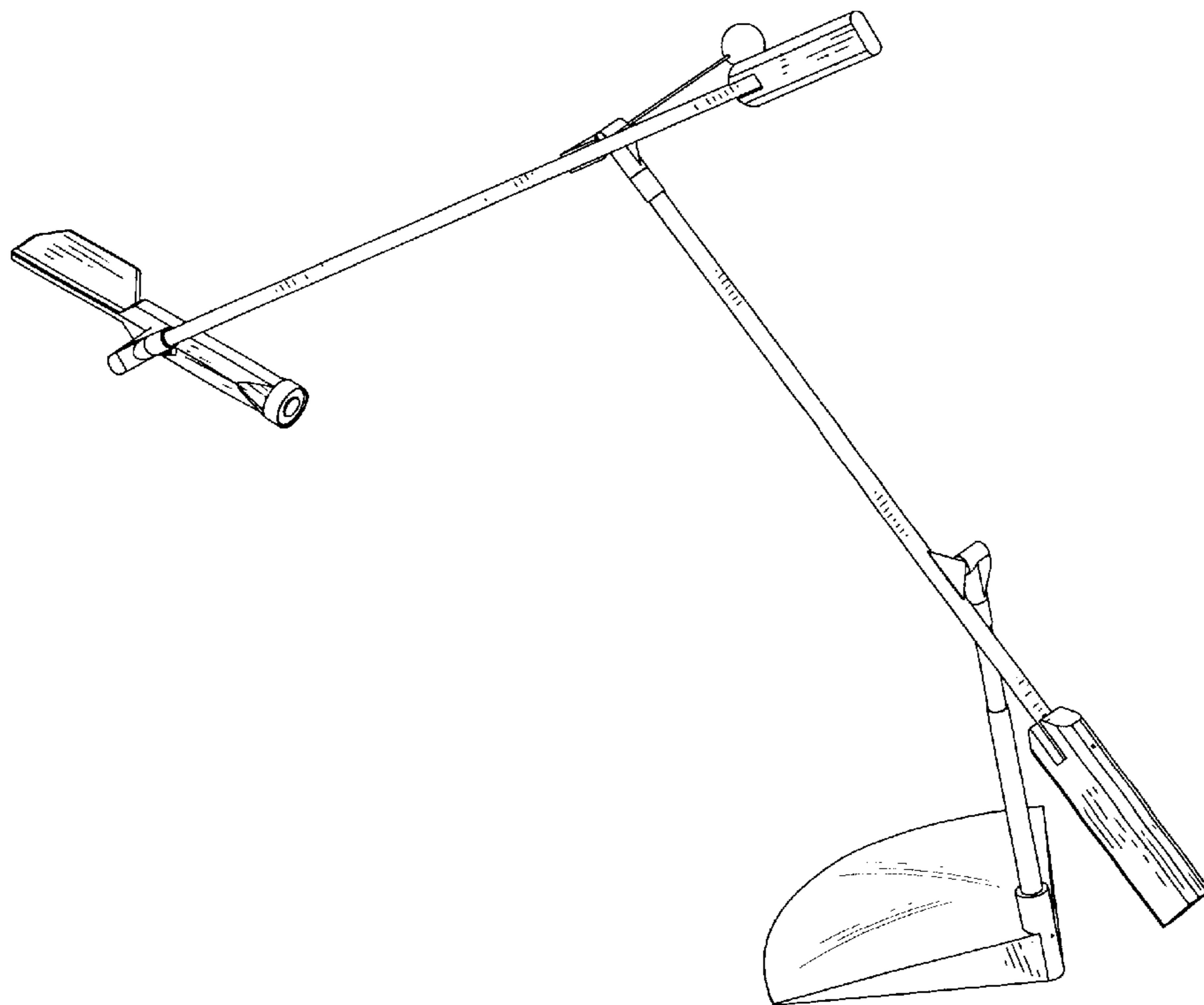

FIG. 8

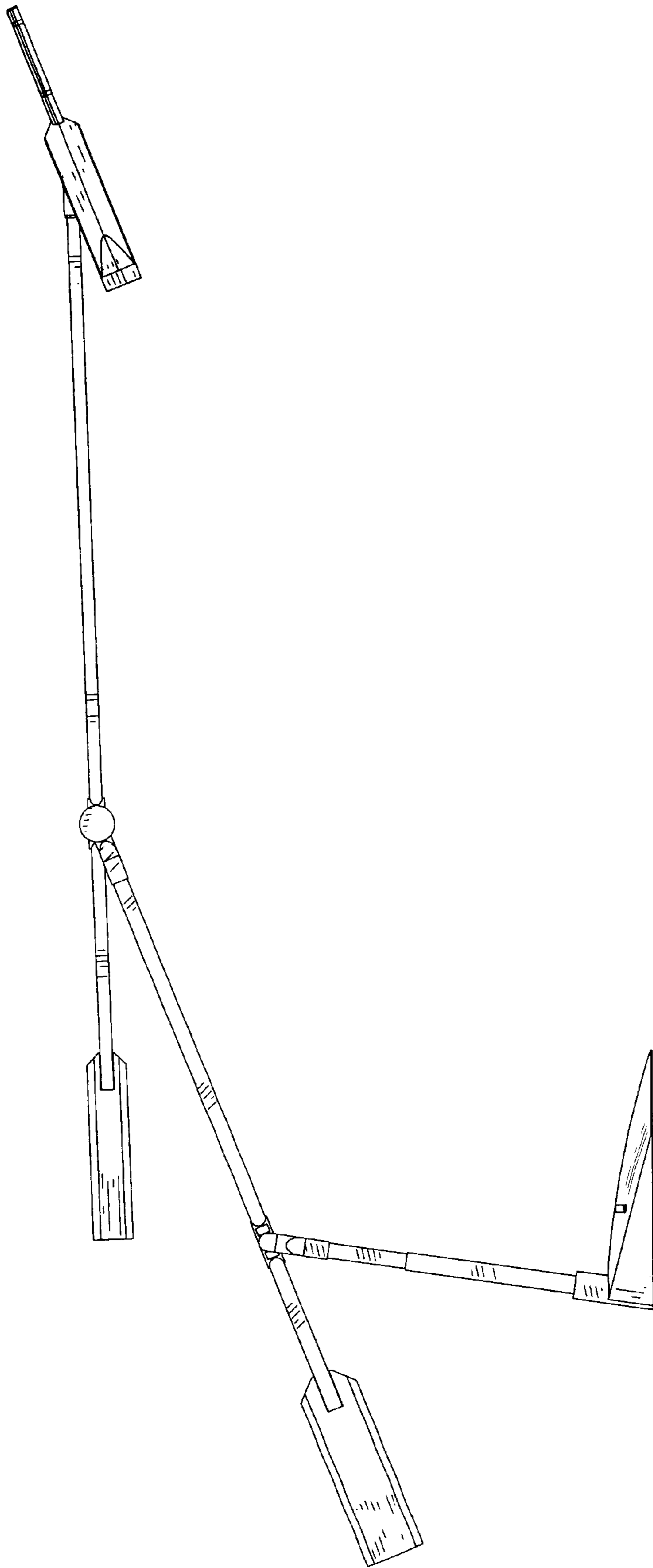

FIG. 9

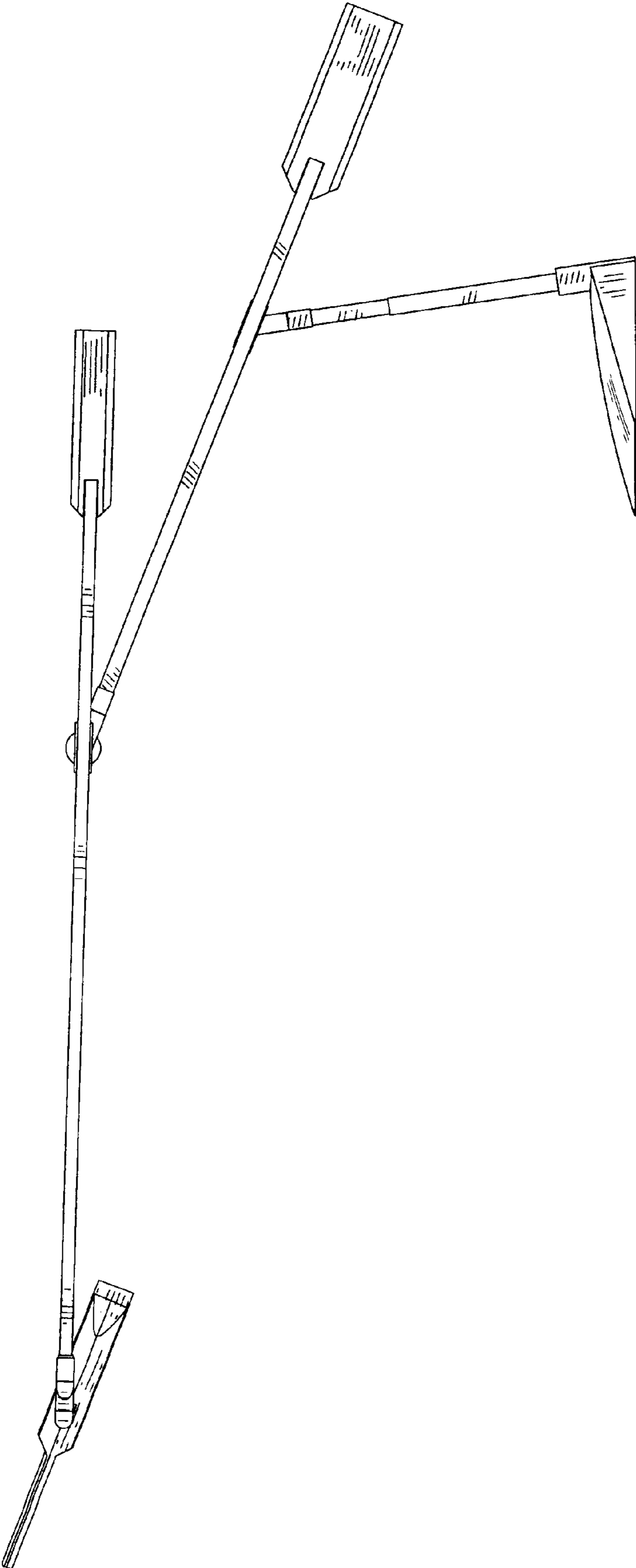

FIG. 10

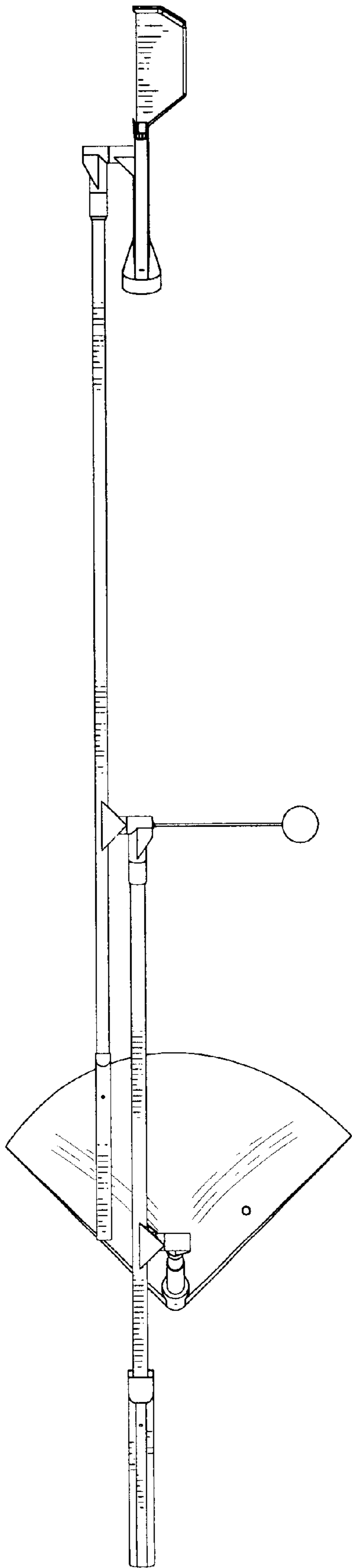

FIG. 11

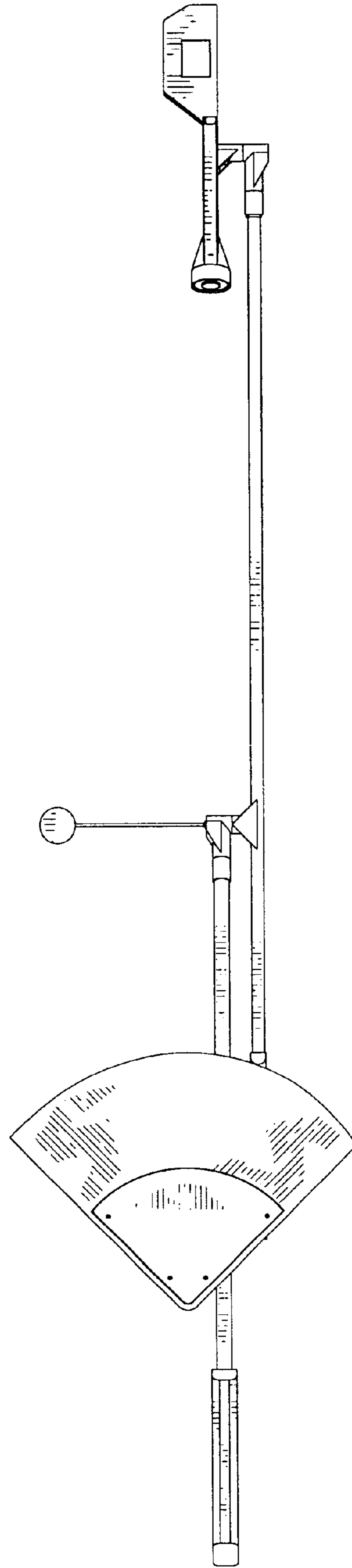

FIG. 12

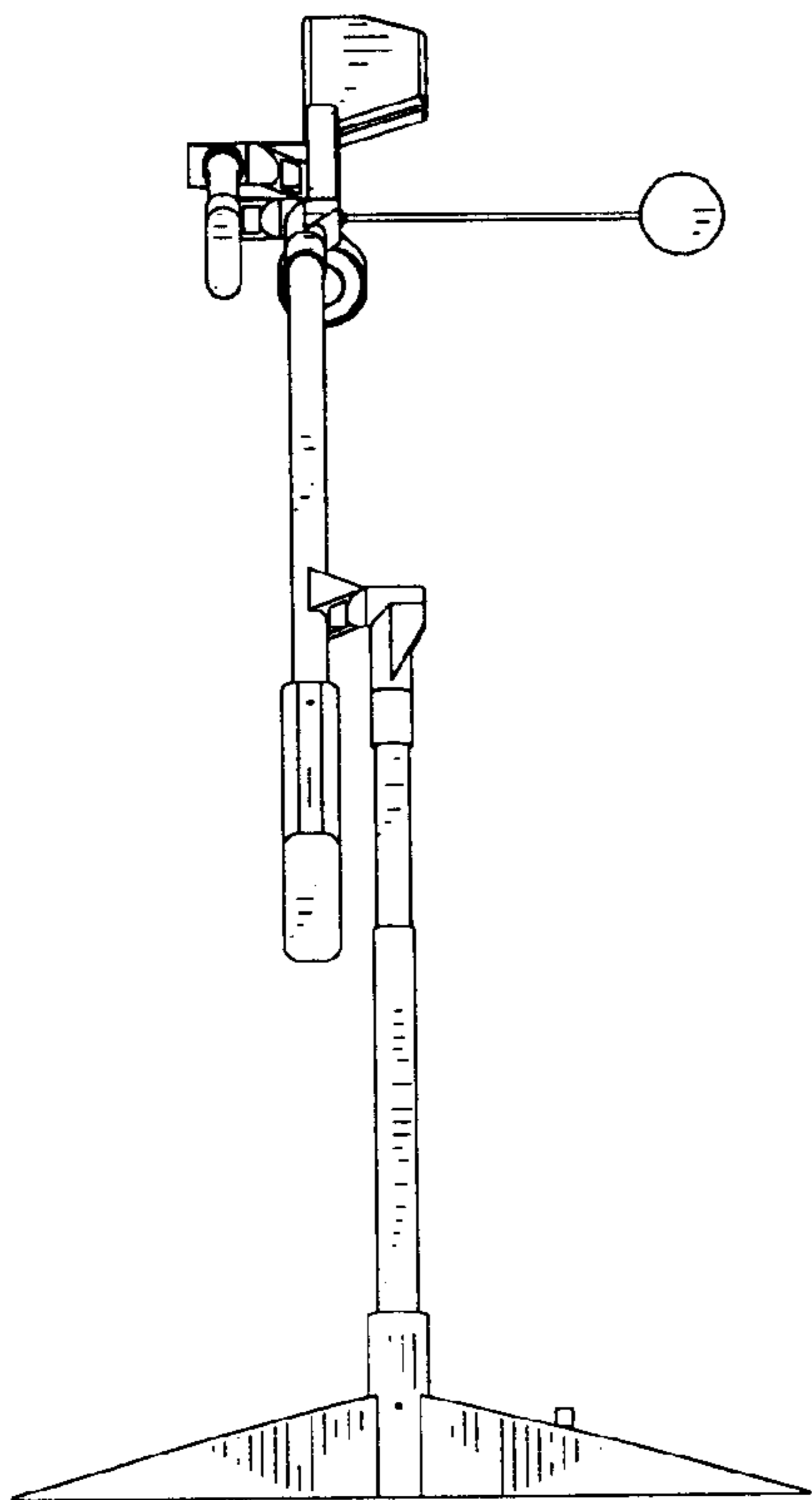

FIG. 13

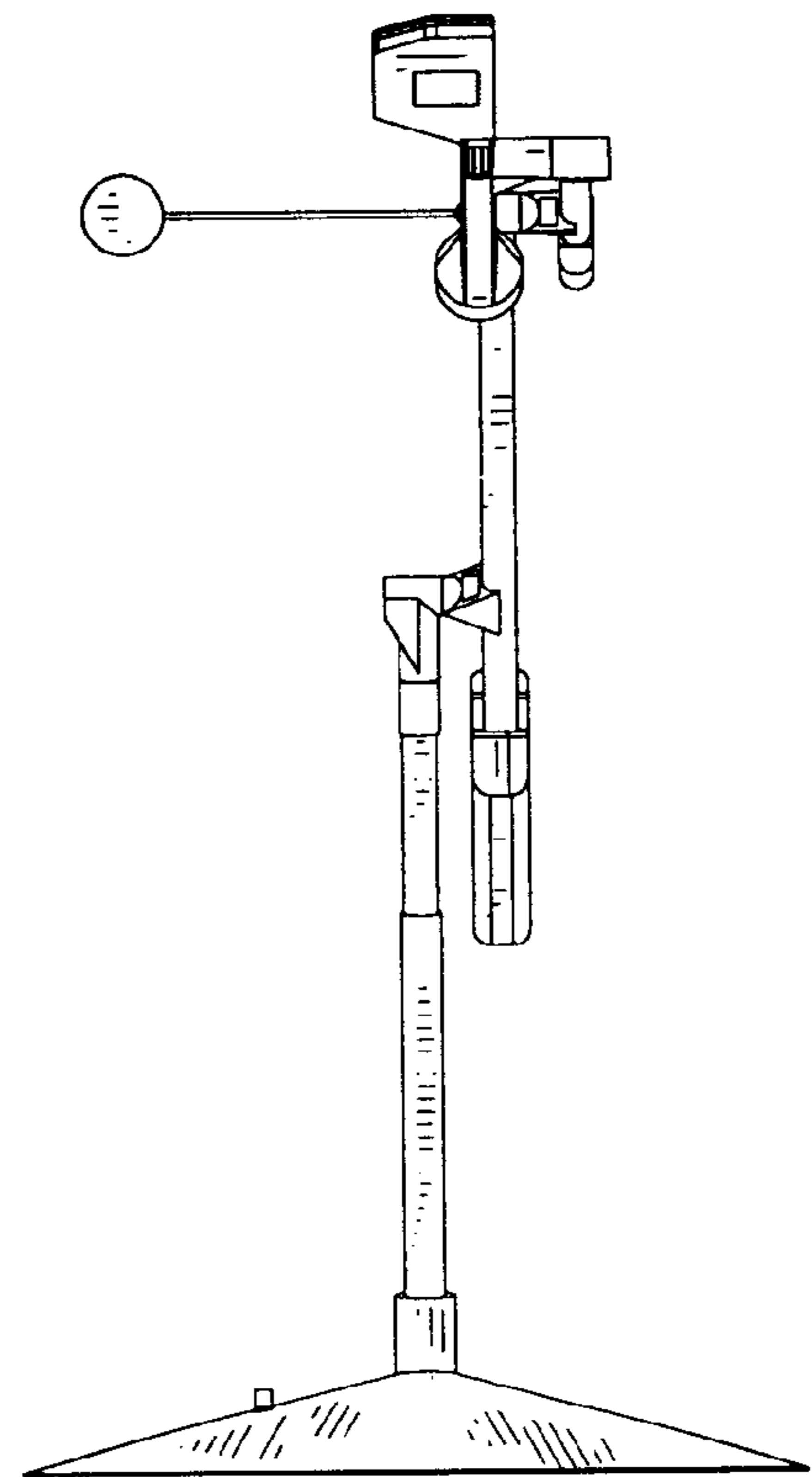

FIG. 14

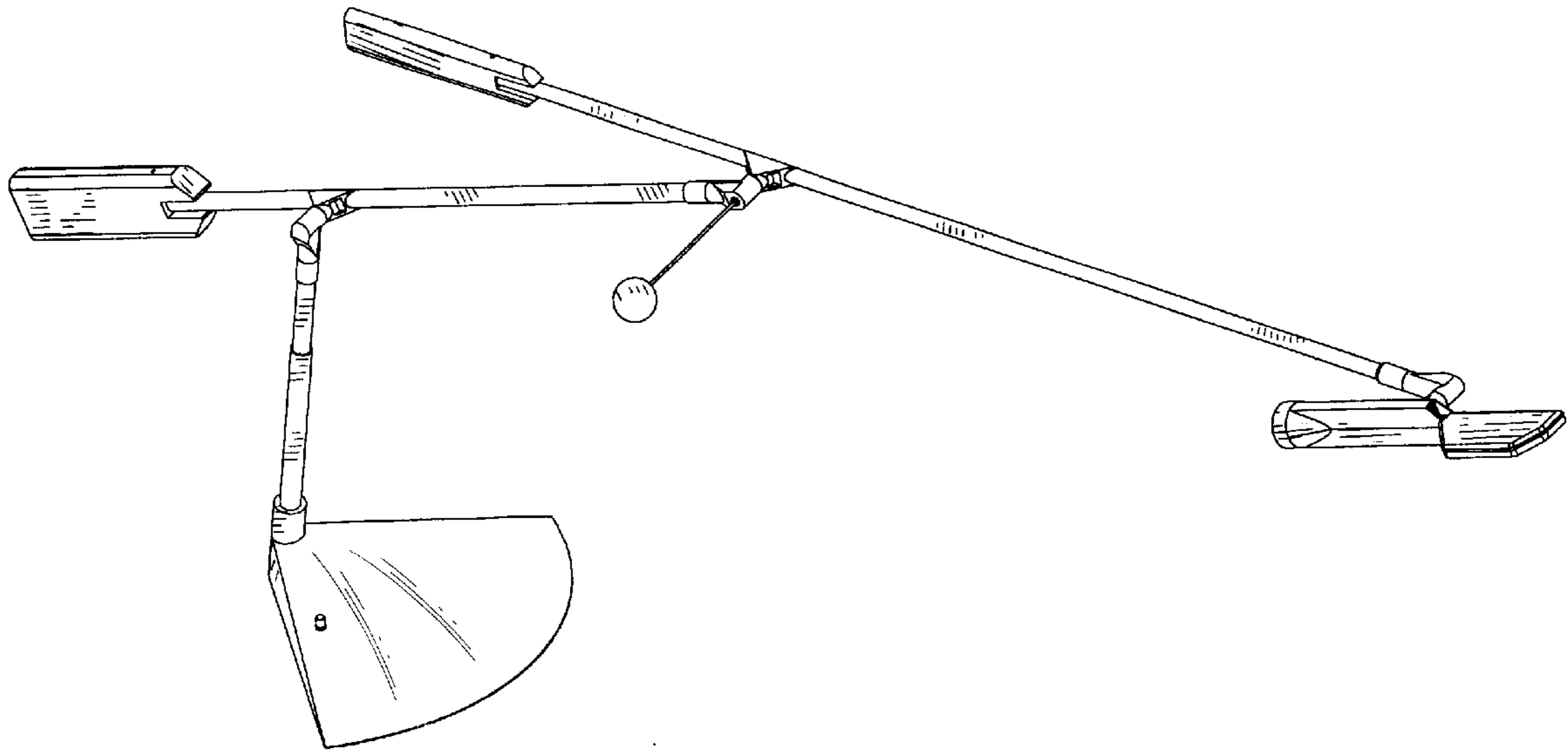

FIG. 15

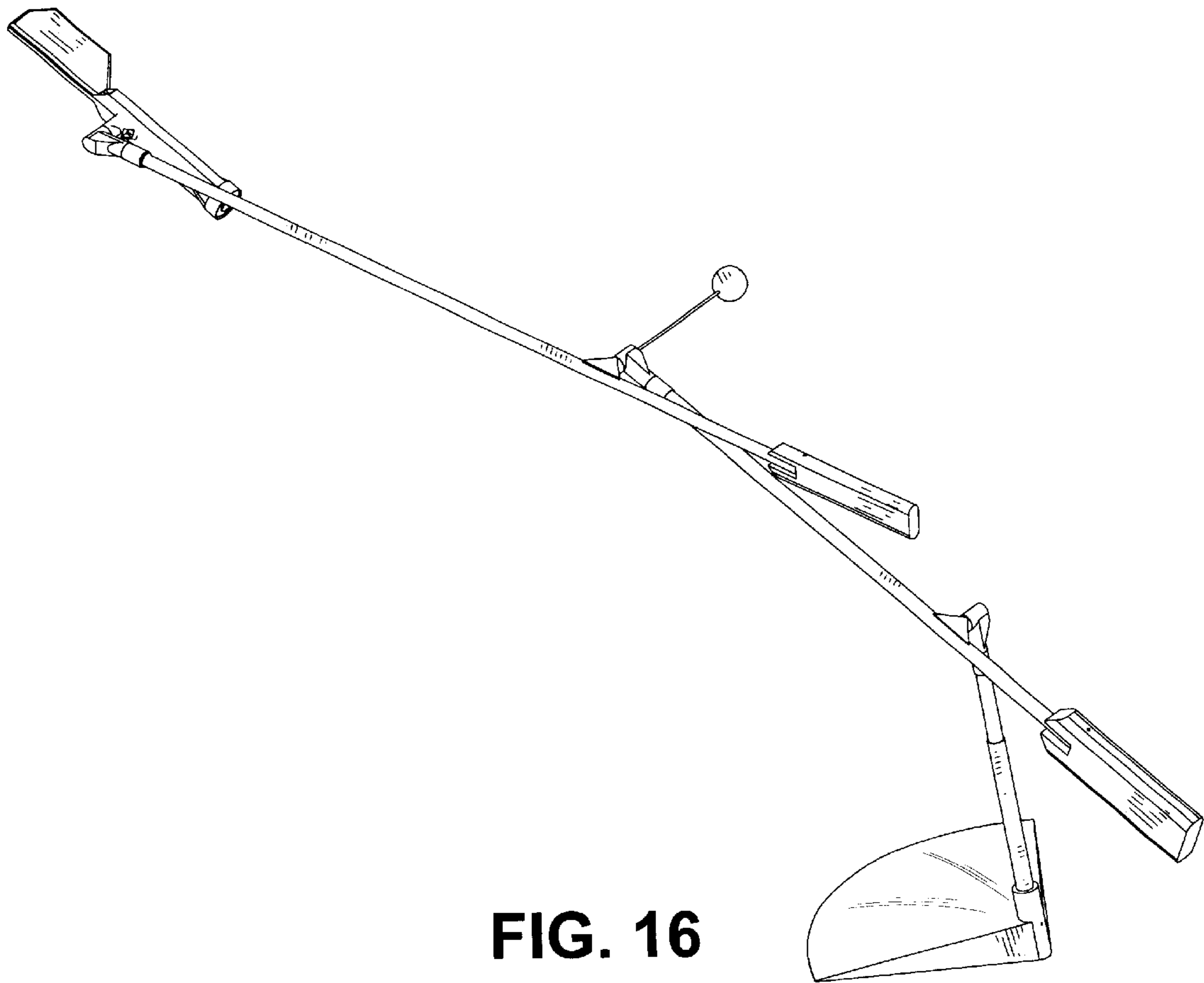

FIG. 16

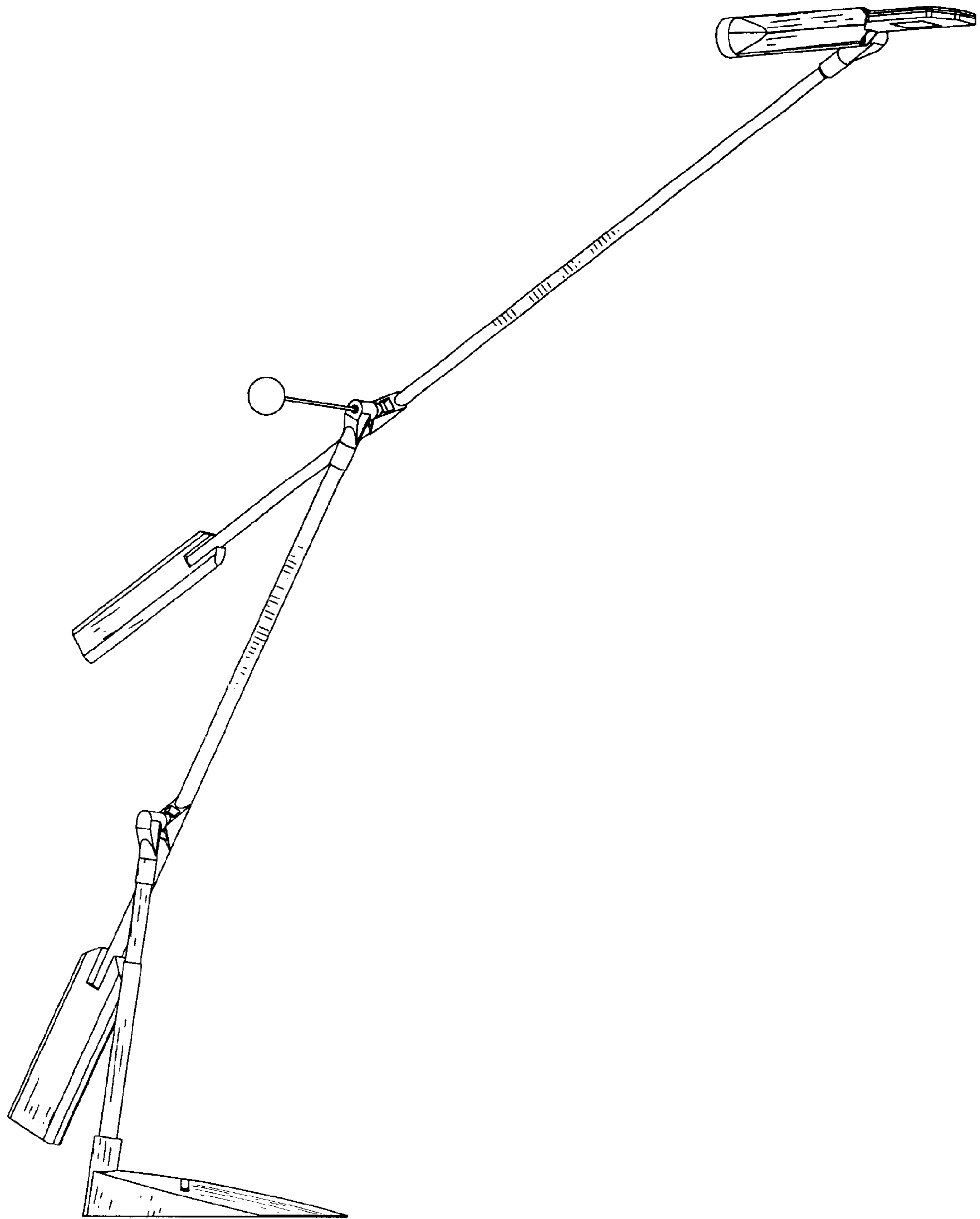

FIG. 17

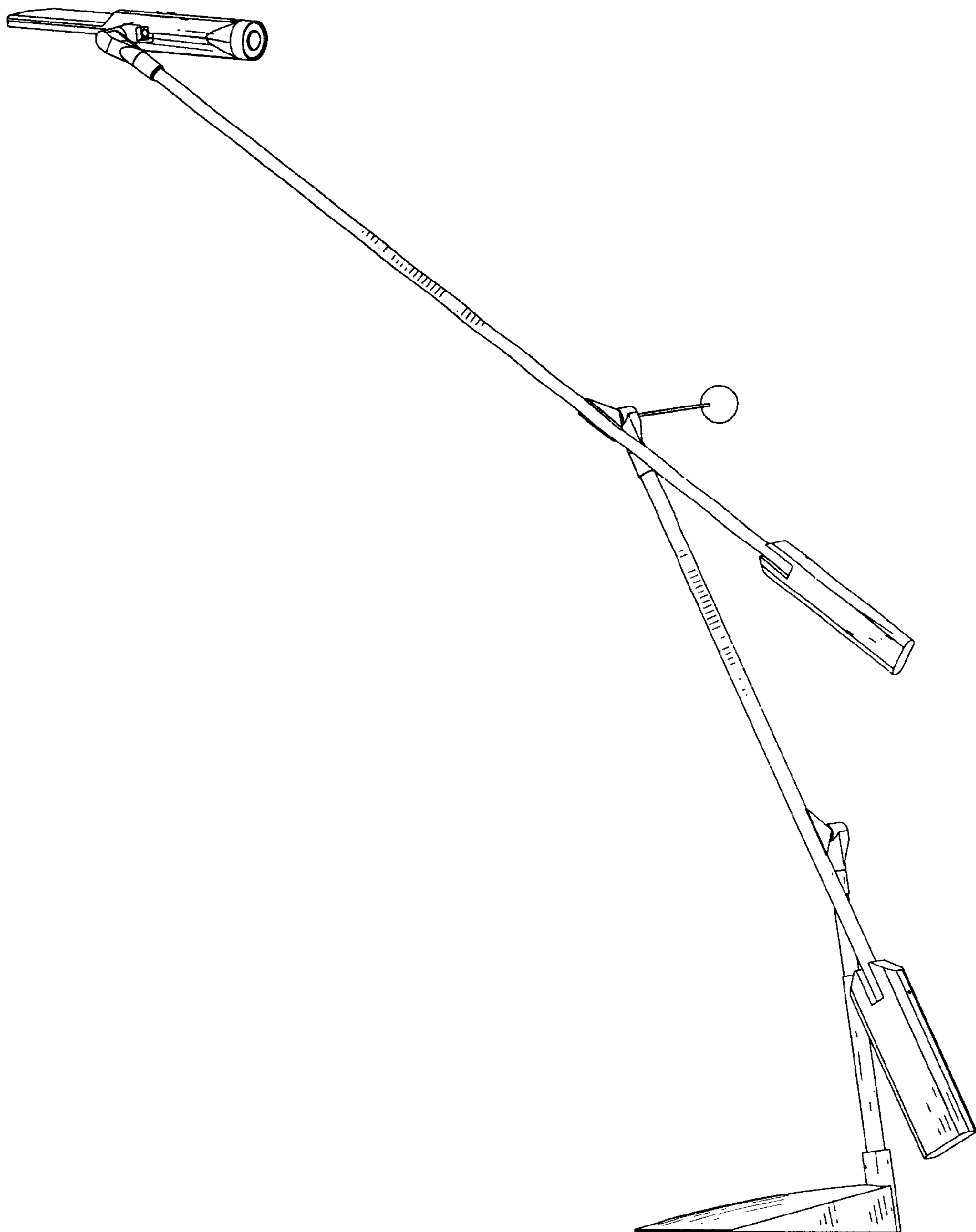

FIG. 18

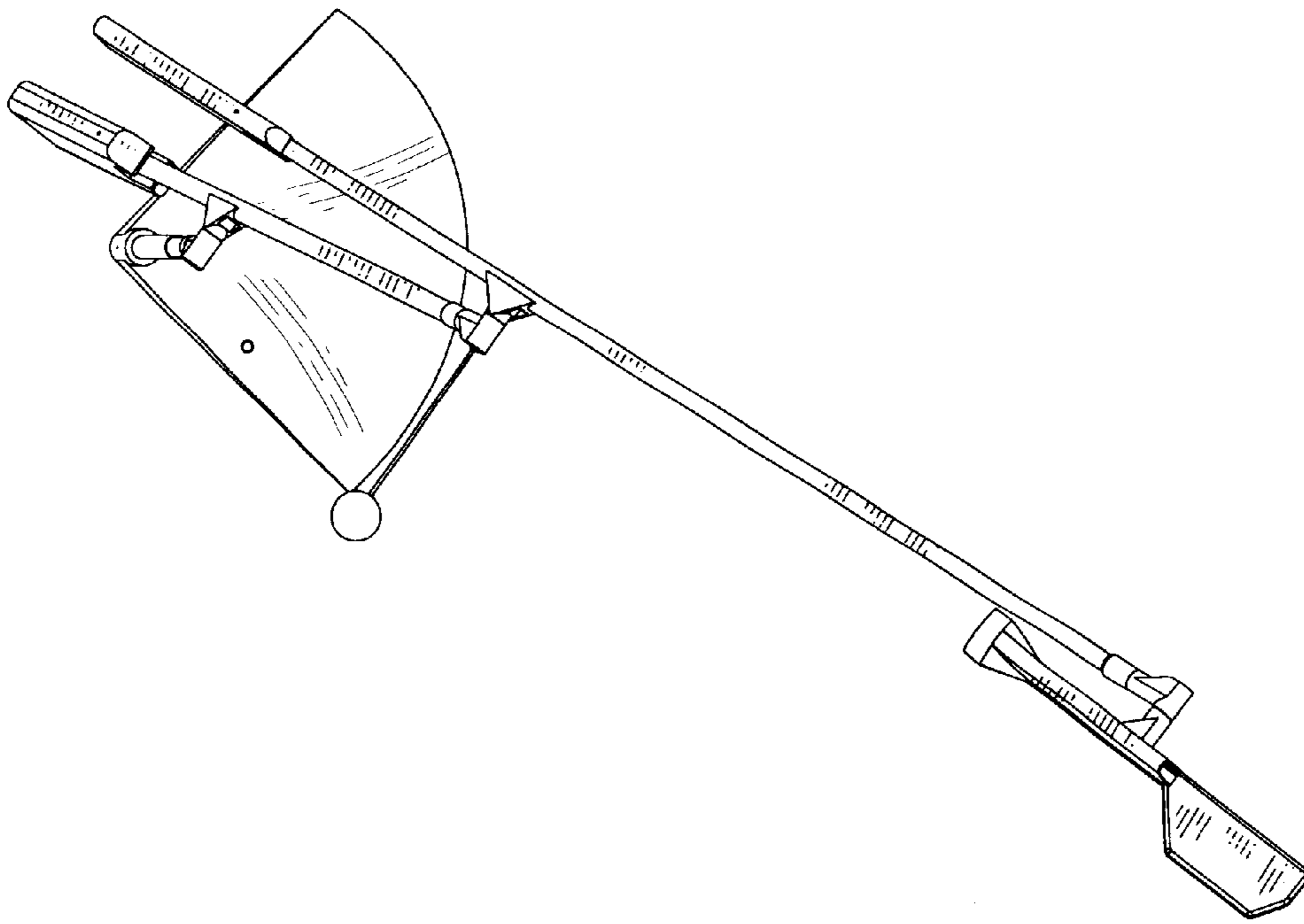

FIG. 19

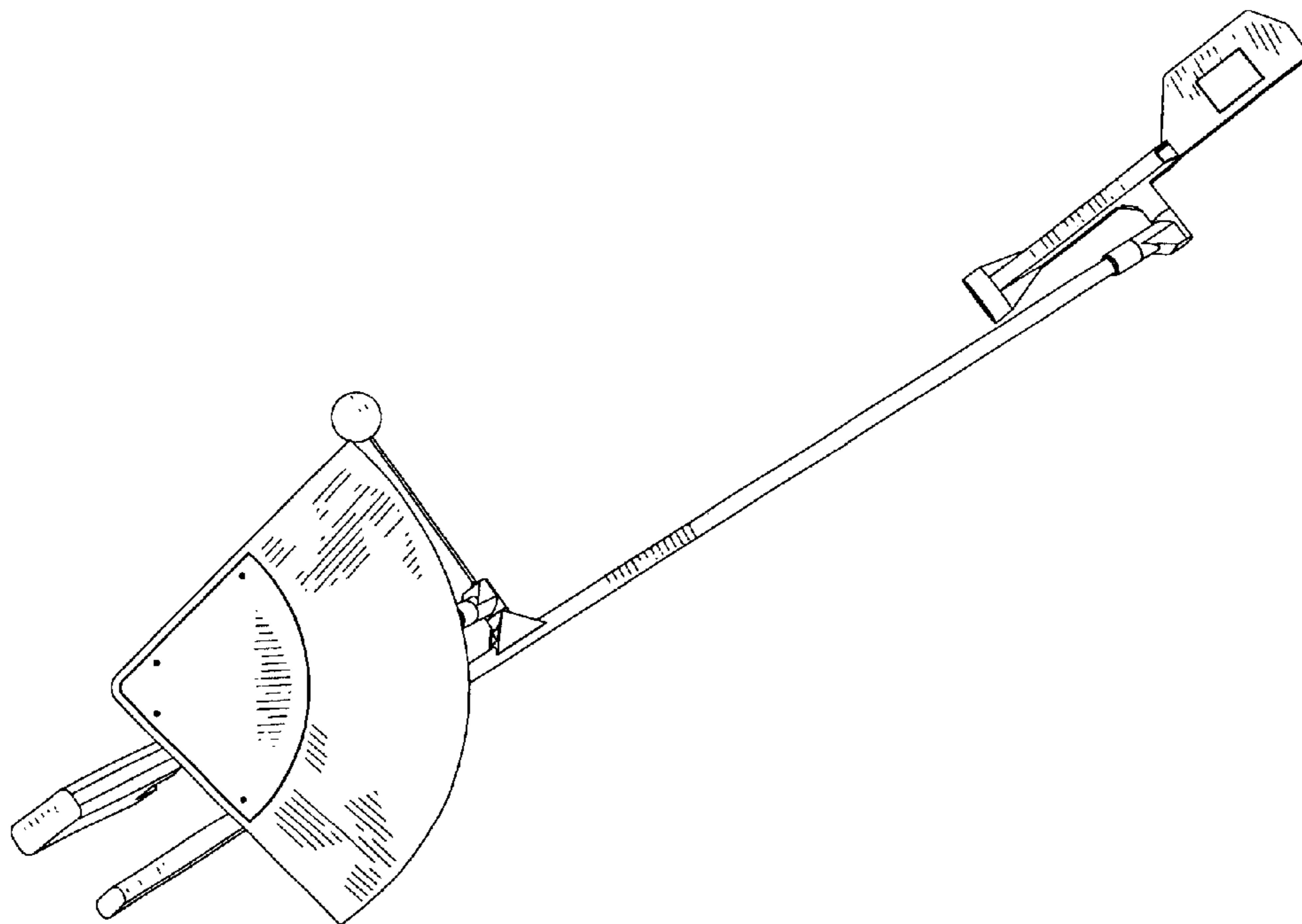

FIG. 20

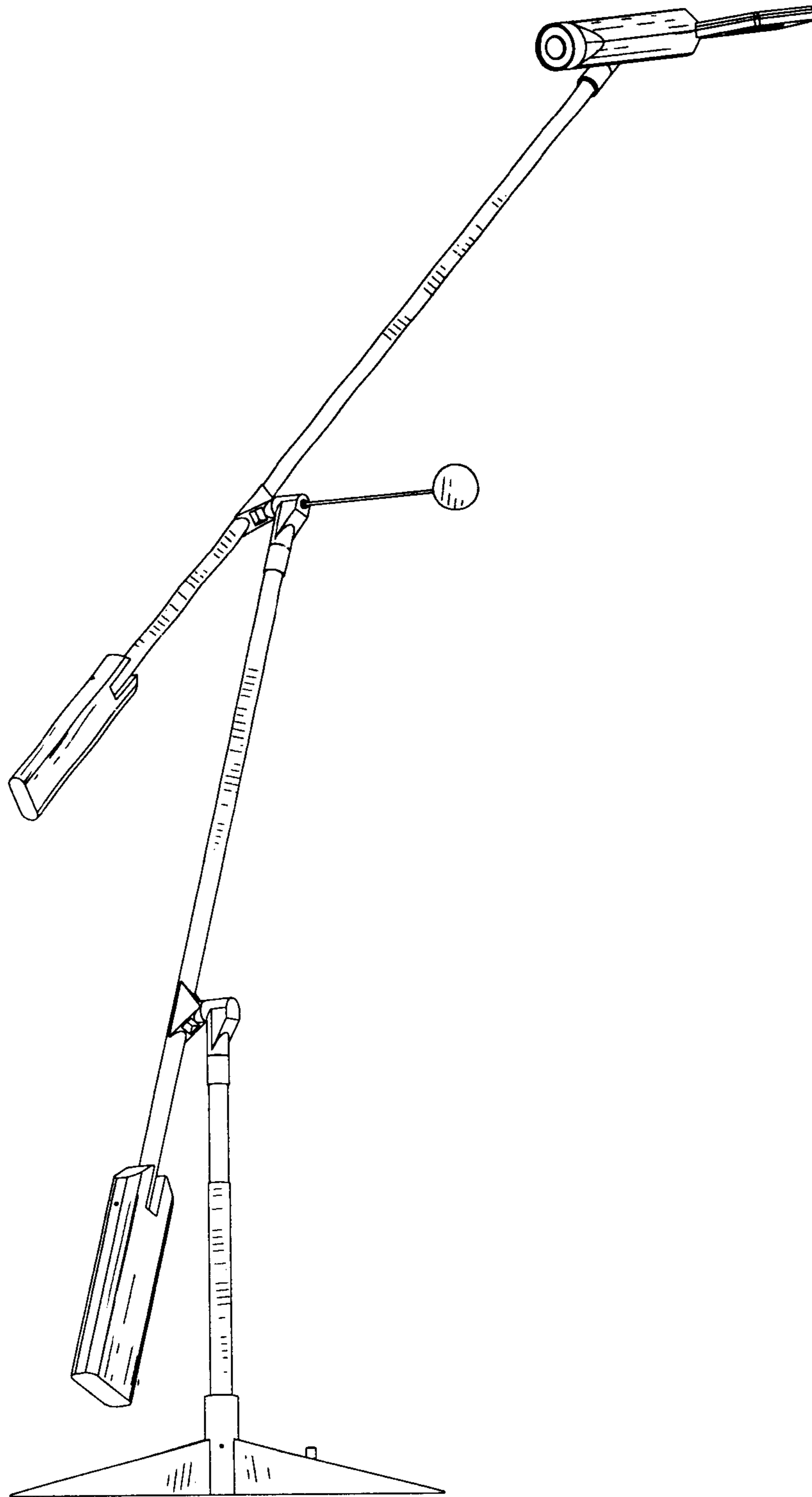

FIG. 21

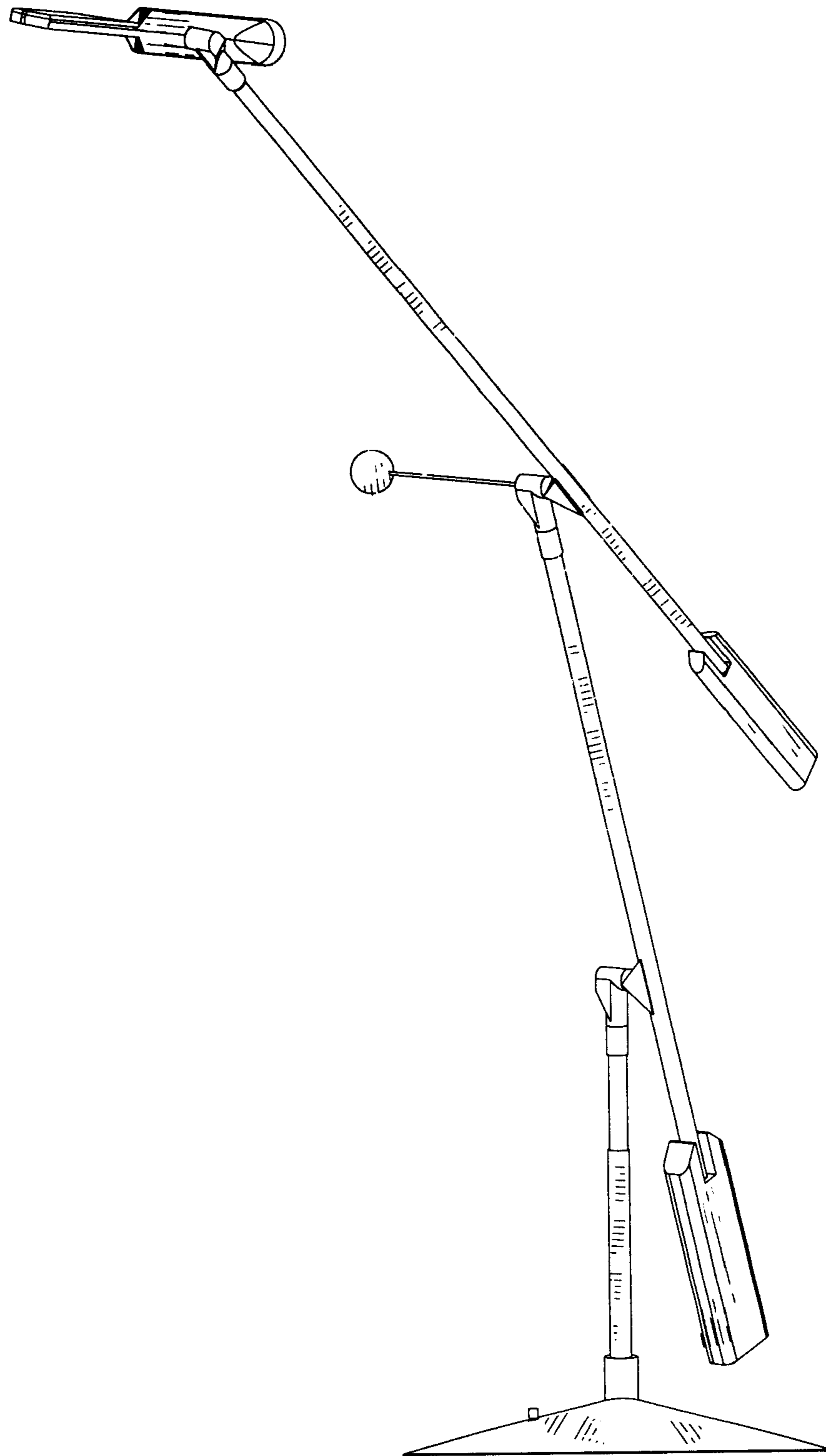

FIG. 22

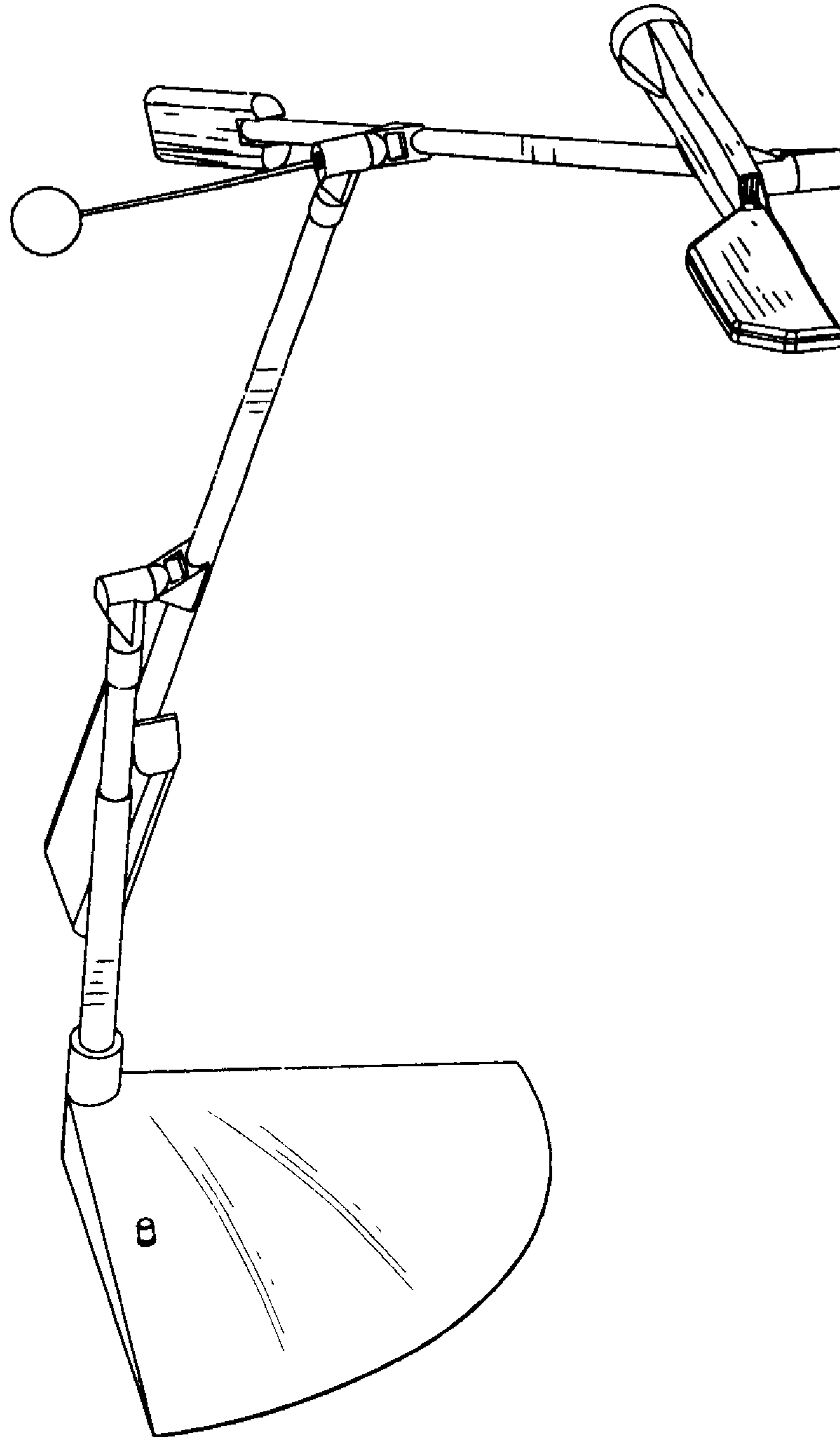

FIG. 23

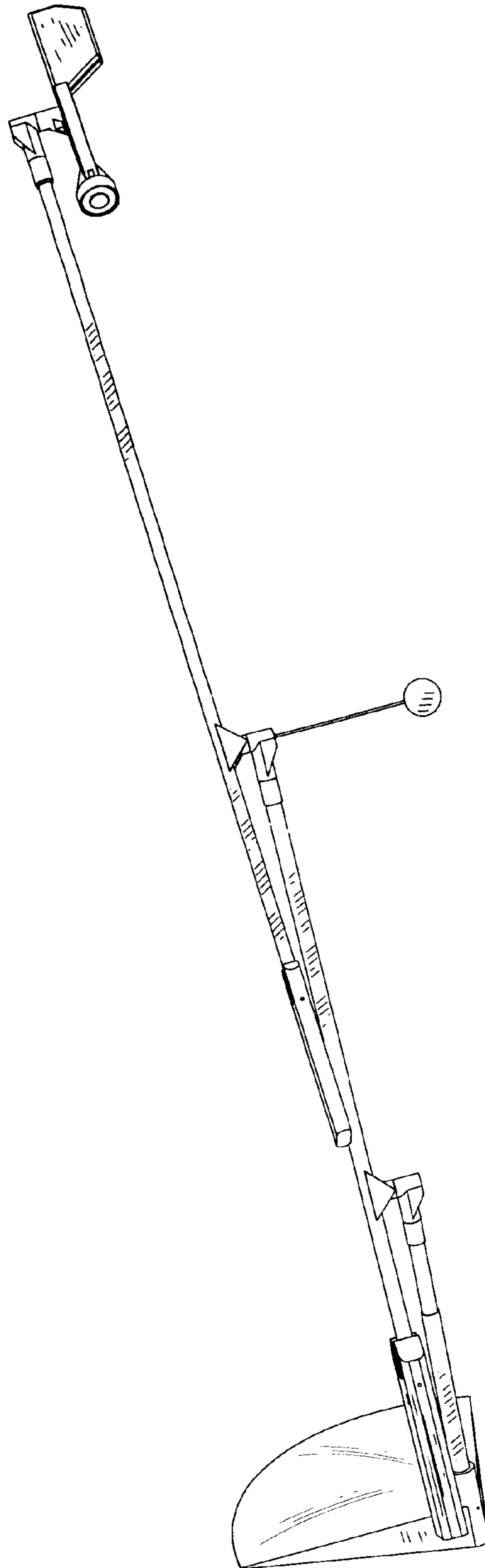

FIG. 24

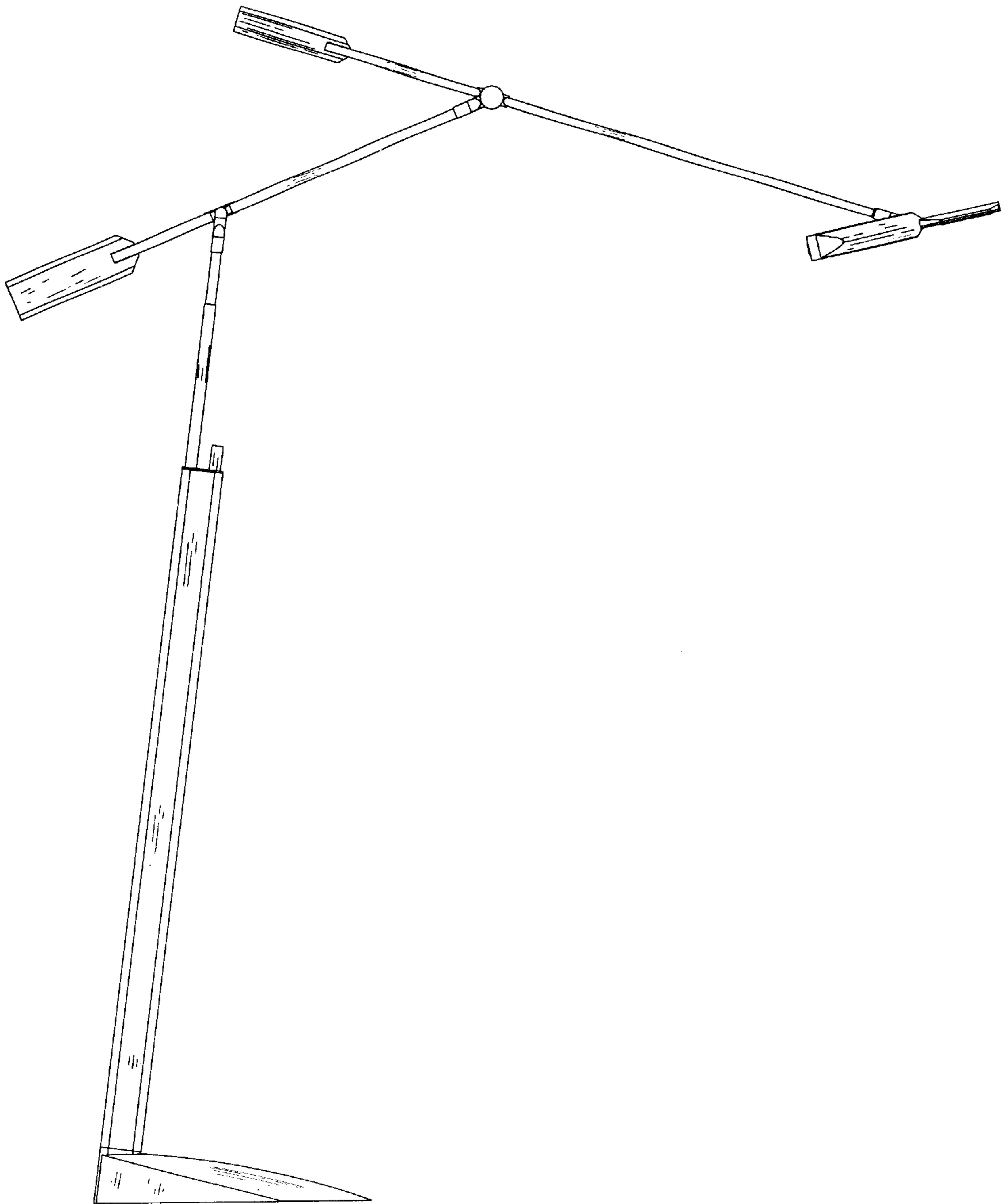

FIG. 25



FIG. 26

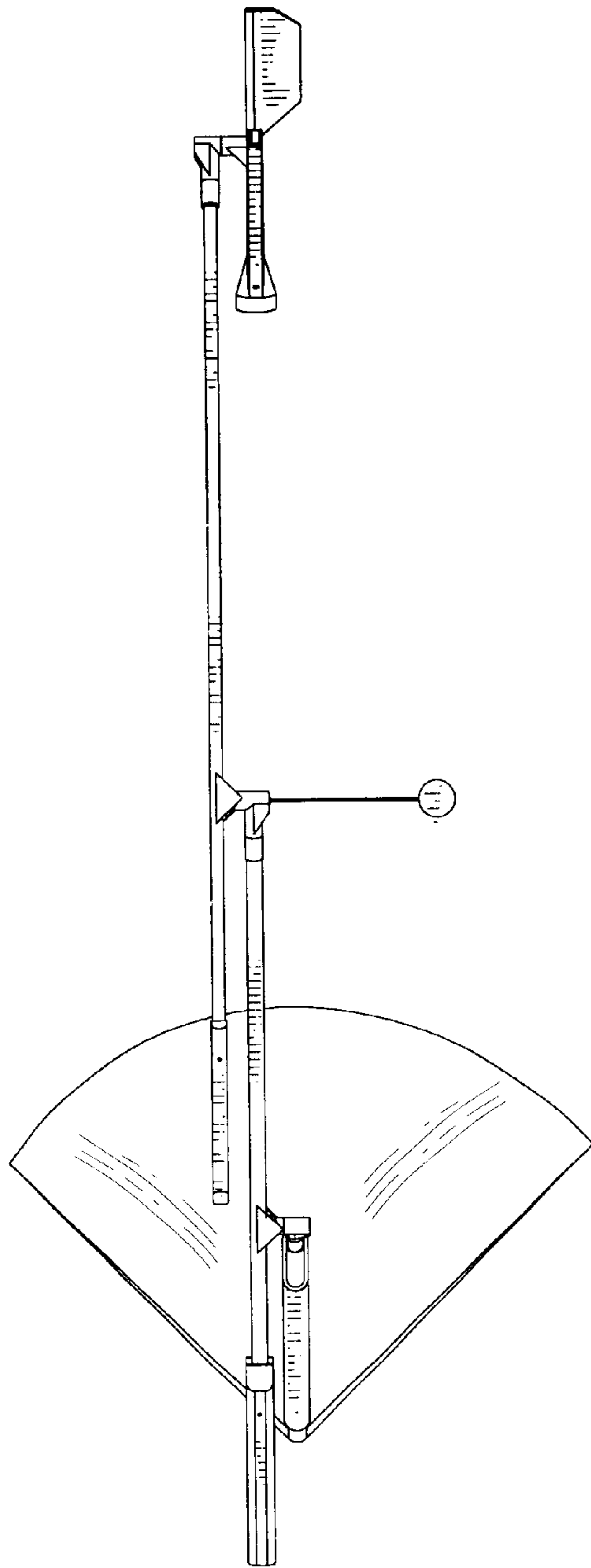

FIG. 27

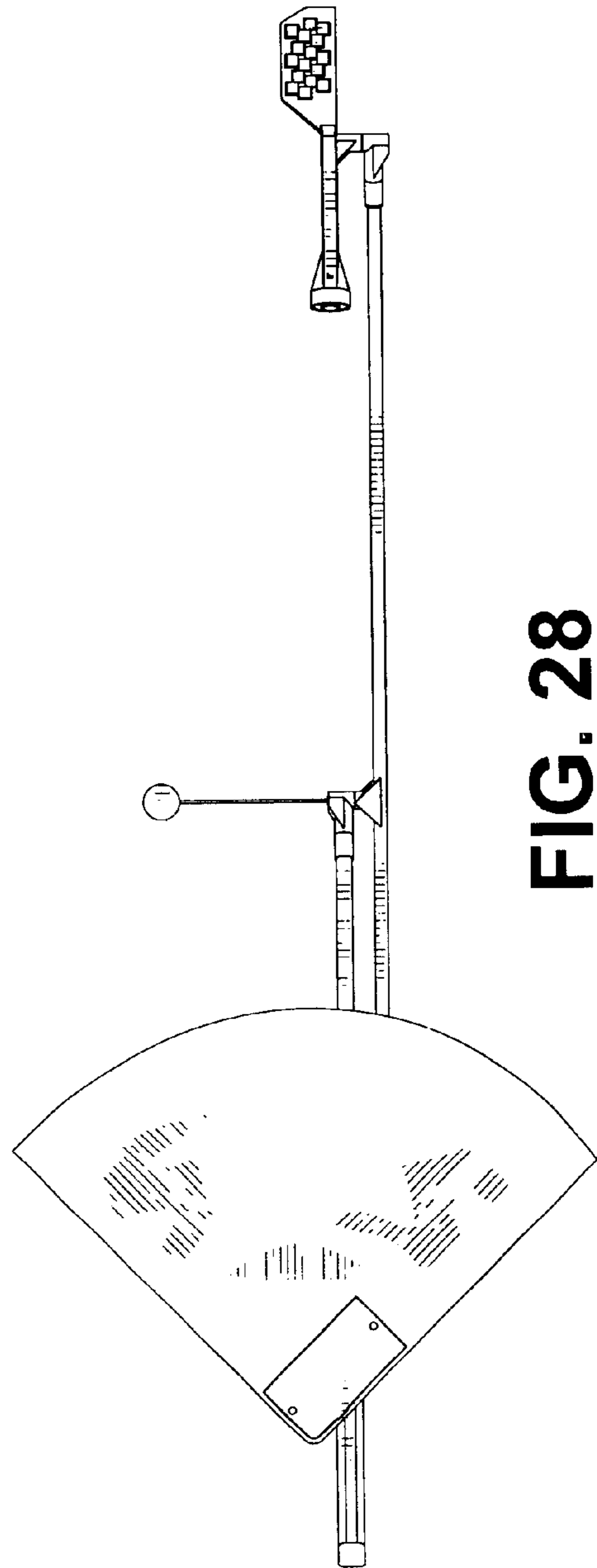

FIG. 28

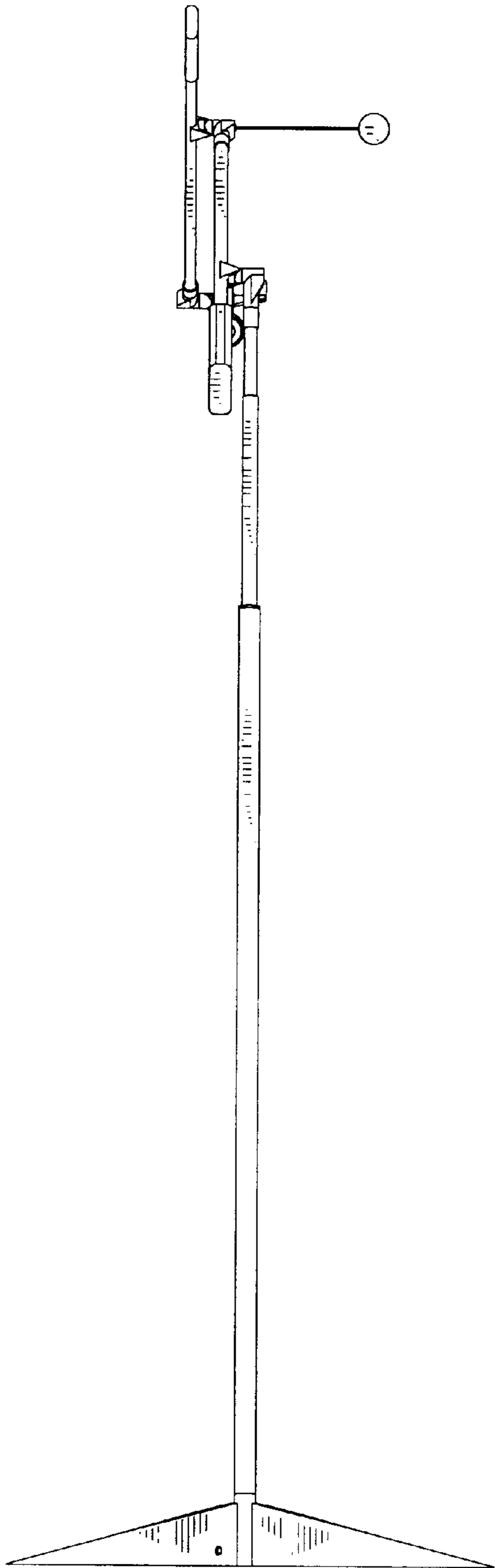

FIG. 29

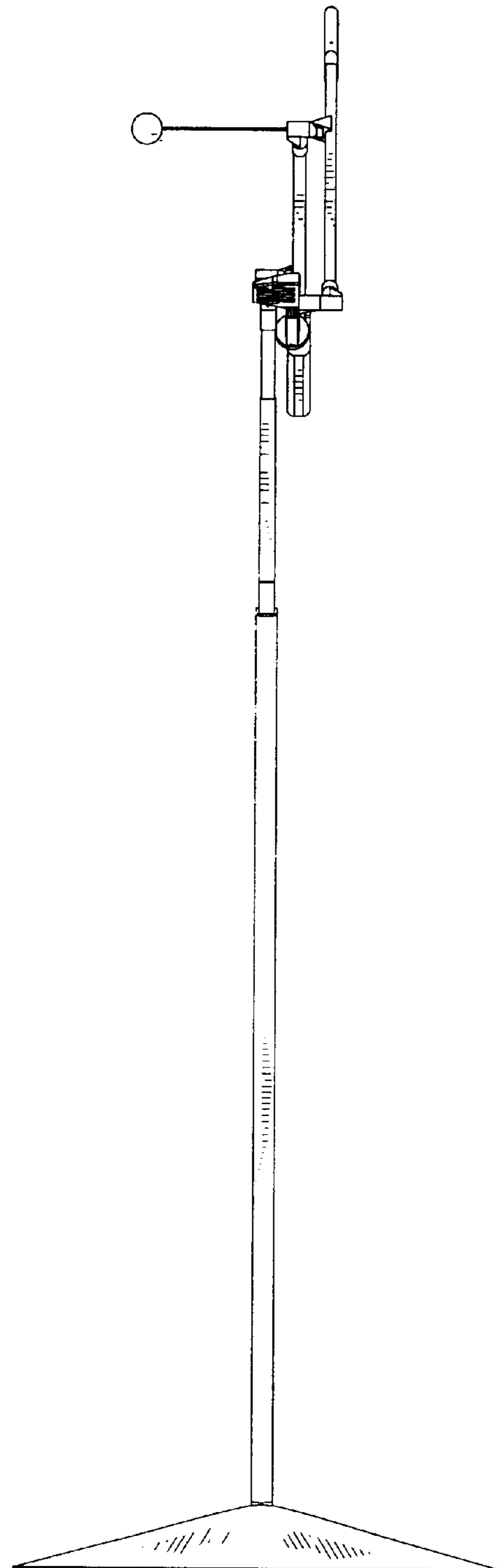

FIG. 30

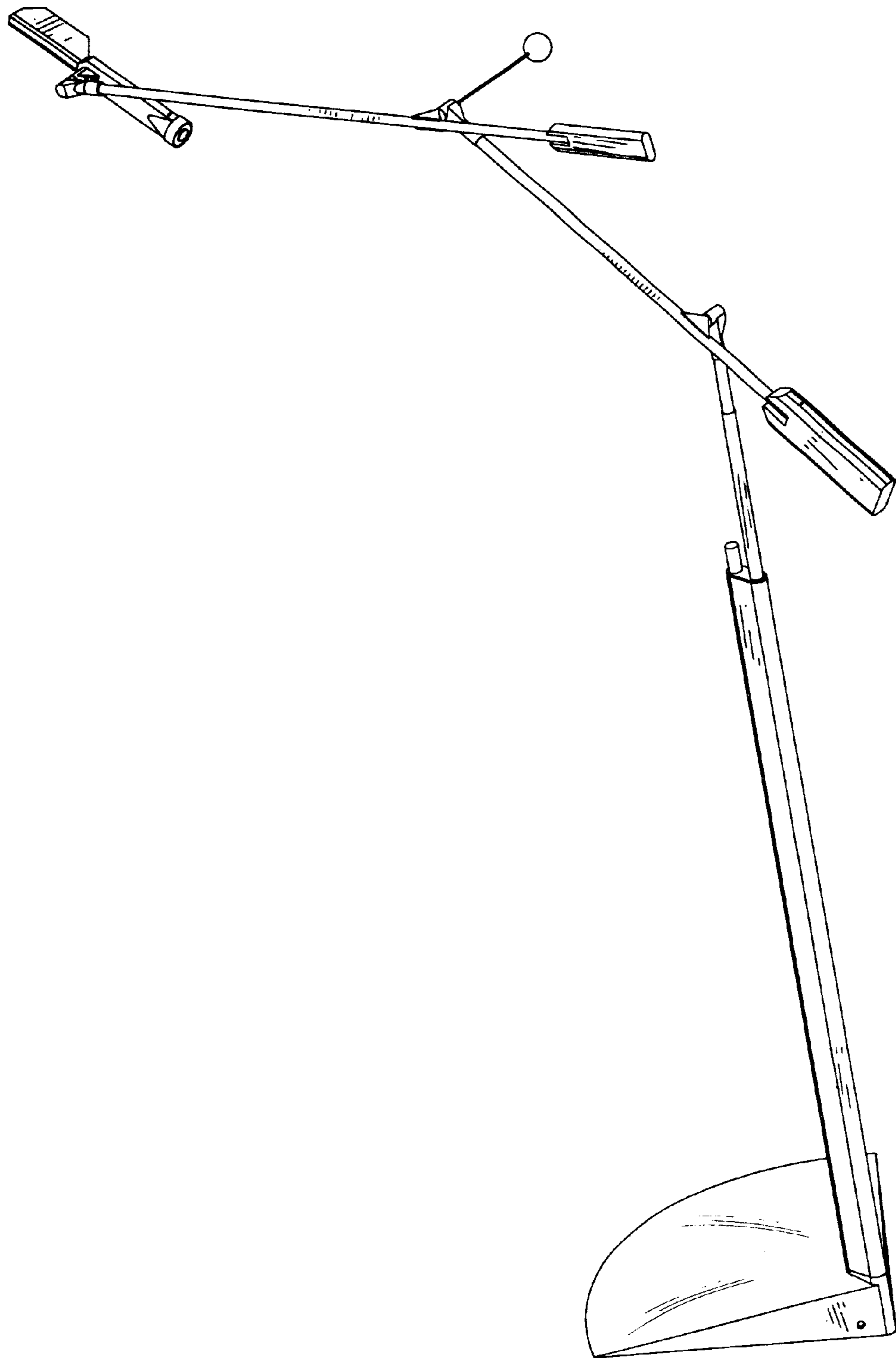

FIG. 31