

US00D521833S

(12) **United States Design Patent**  
**Okuda et al.**

(10) **Patent No.: US D521,833 S**  
(45) **Date of Patent: \*\* May 30, 2006**

(54) **PORTABLE ELECTRIC GRINDER**

(75) Inventors: **Shinsuke Okuda**, Anjo (JP); **Shin Sugiura**, Anjo (JP)

(73) Assignee: **Makita Corporation**, Anjo (JP)

(\*\*) Term: **14 Years**

(21) Appl. No.: **29/236,525**

(22) Filed: **Aug. 18, 2005**

(30) **Foreign Application Priority Data**

Feb. 25, 2005 (JP) ..... 2005-005436

(51) **LOC (8) Cl.** ..... **08-01**

(52) **U.S. Cl.** ..... **D8/62**

(58) **Field of Classification Search** ..... D8/69,  
D8/67, 62, 61; 451/359, 358, 357, 356, 354,  
451/353, 351, 344, 294; 173/168  
See application file for complete search history.

(56) **References Cited**

**U.S. PATENT DOCUMENTS**

D301,830 S	*	6/1989	Ogawa et al.	.....	D8/62
D328,841 S	*	8/1992	Fushiya et al.	.....	D8/62
D332,559 S	*	1/1993	Miyoshi et al.	.....	D8/62
D347,153 S	*	5/1994	Uneyama	.....	D8/62
D351,772 S	*	10/1994	Price	.....	D8/62
D378,183 S	*	2/1997	Dognini	.....	D8/62
D394,594 S	*	5/1998	Chung	.....	D8/62
D402,870 S	*	12/1998	Etter et al.	.....	D8/62

D408,244 S	*	4/1999	Price	.....	D8/62
D437,199 S	*	2/2001	Robson	.....	D8/62
D453,098 S	*	1/2002	Pretzell	.....	D8/62
D468,179 S	*	1/2003	Hayakawa et al.	.....	D8/62
6,527,630 B1	*	3/2003	Mannsperger et al.	.....	451/344
D479,452 S	*	9/2003	Cho	.....	D8/62
D479,969 S	*	9/2003	Robson et al.	.....	D8/62
D498,653 S	*	11/2004	Wu	.....	D8/62
D500,945 S	*	1/2005	Wright	.....	D8/62

**FOREIGN PATENT DOCUMENTS**

DE 499 04 554 9/1999

\* cited by examiner

*Primary Examiner*—Cathron C. Brooks

*Assistant Examiner*—Austin Murphy

(74) *Attorney, Agent, or Firm*—Oliff & Berridge, PLC

(57) **CLAIM**

The ornamental design for a portable electric grinder, as shown and described.

**DESCRIPTION**

FIG. 1 is a perspective view of a portable electric grinder showing our new design;

FIG. 2 is a front elevation view thereof;

FIG. 3 is a rear elevation view thereof;

FIG. 4 is a left side elevation view thereof;

FIG. 5 is a right side elevation view thereof;

FIG. 6 is a top plan view thereof; and,

FIG. 7 is a bottom plan view thereof.

**1 Claim, 5 Drawing Sheets**

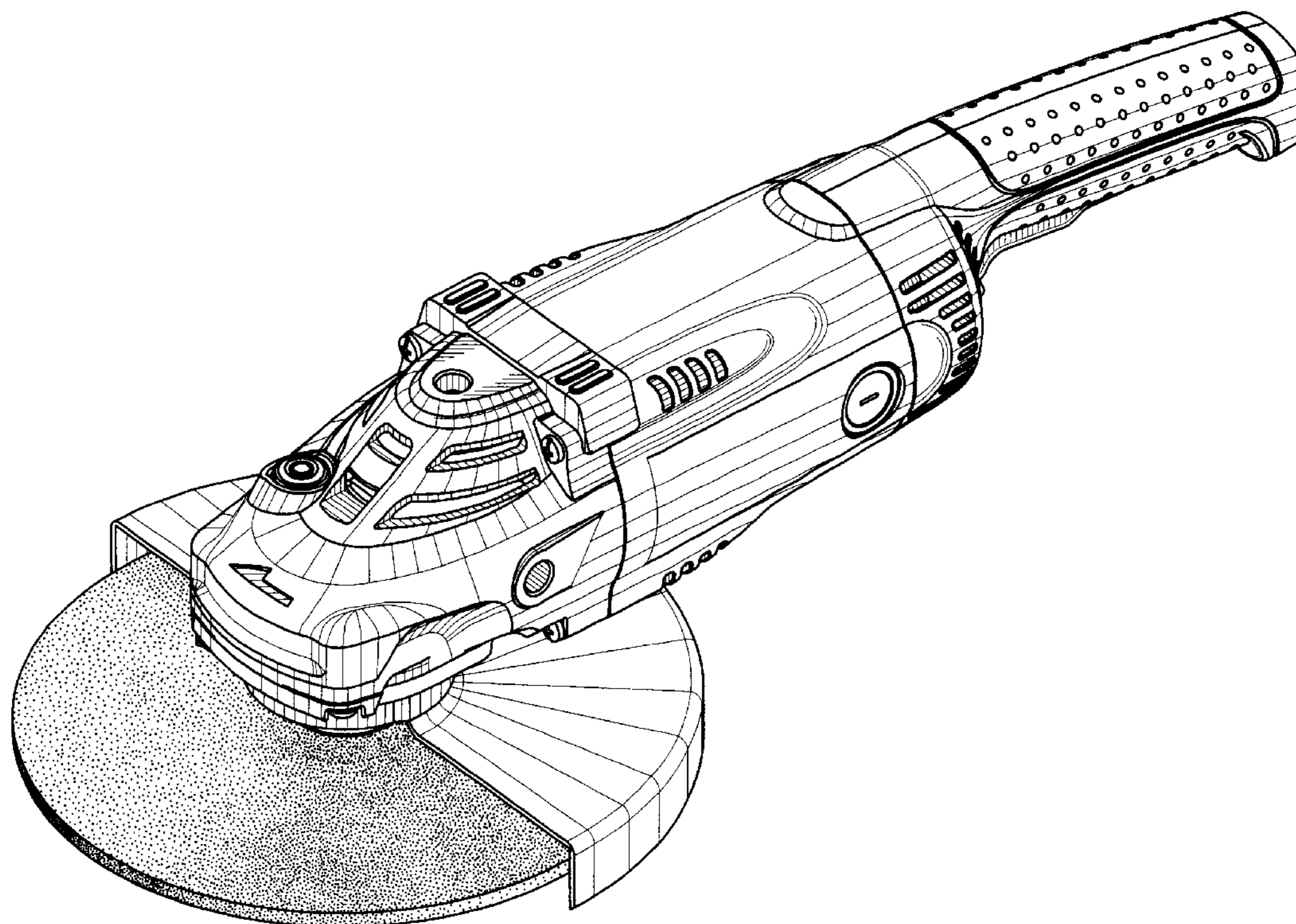

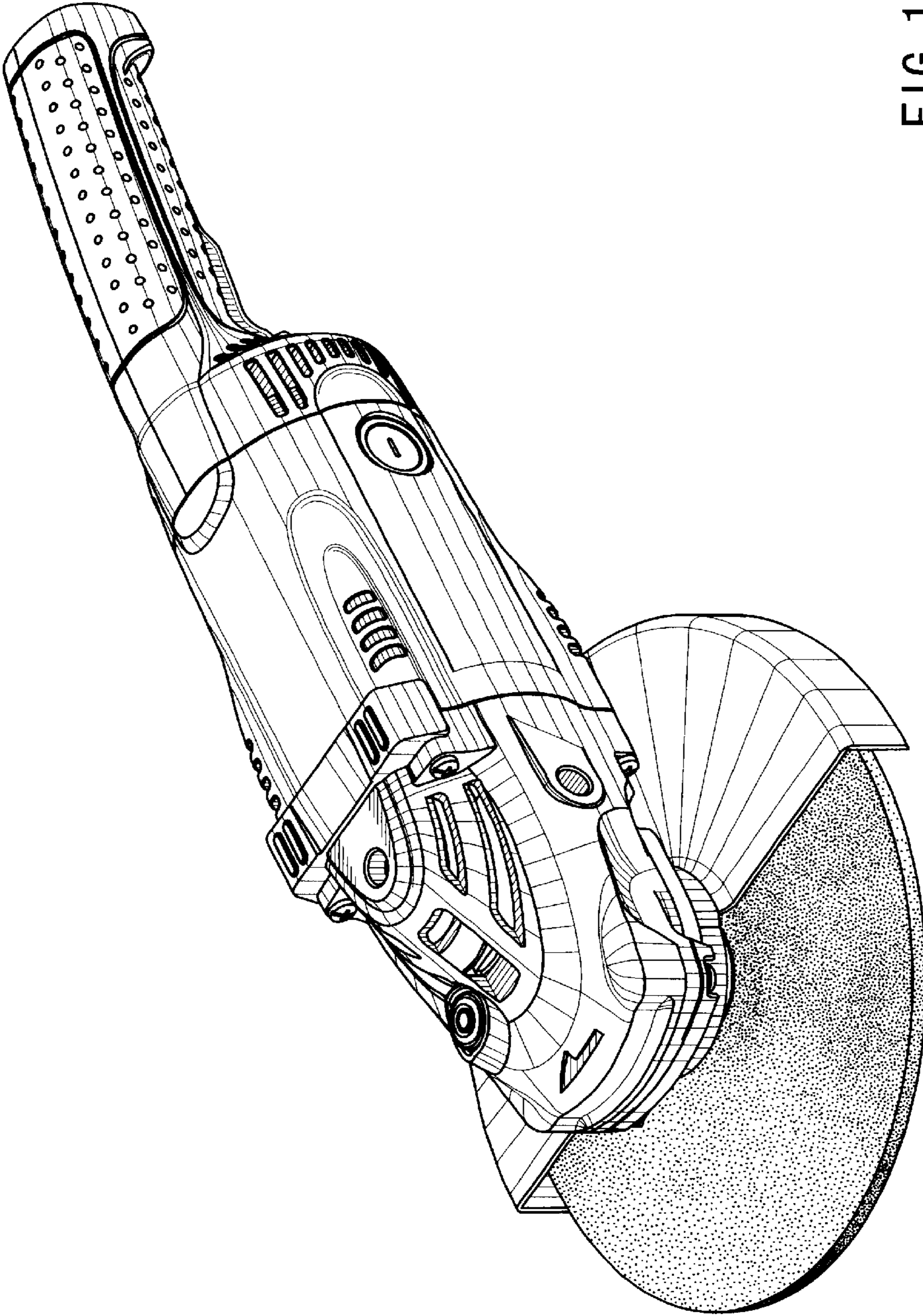

FIG. 1

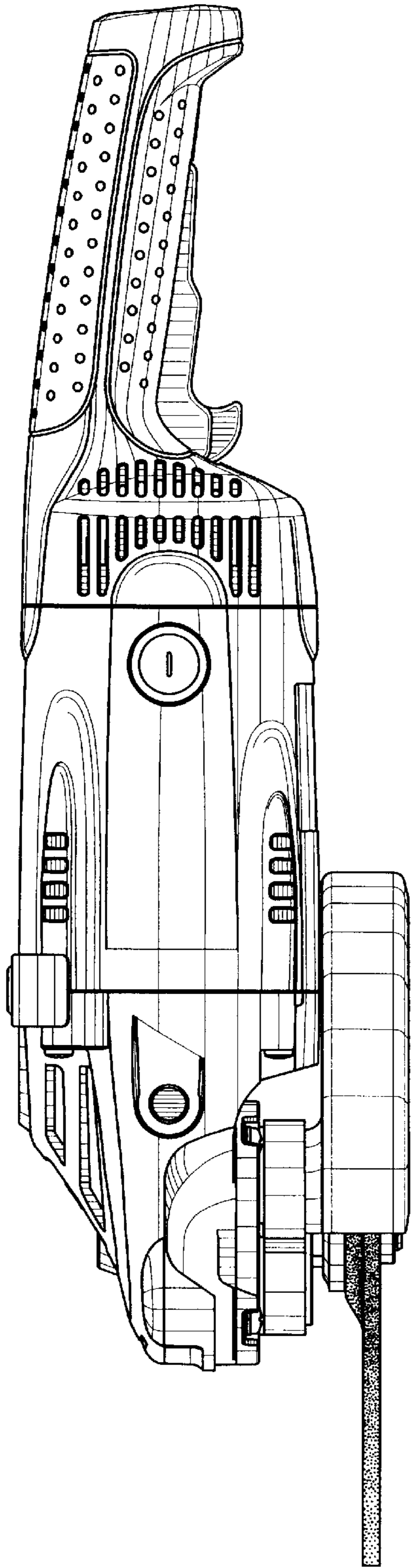

FIG. 2

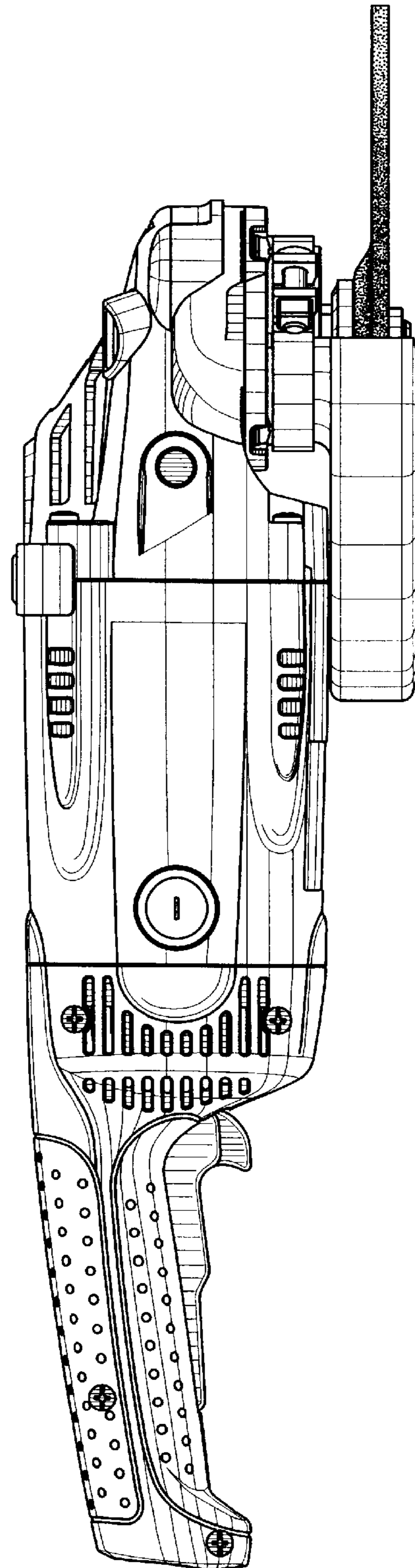

FIG. 3

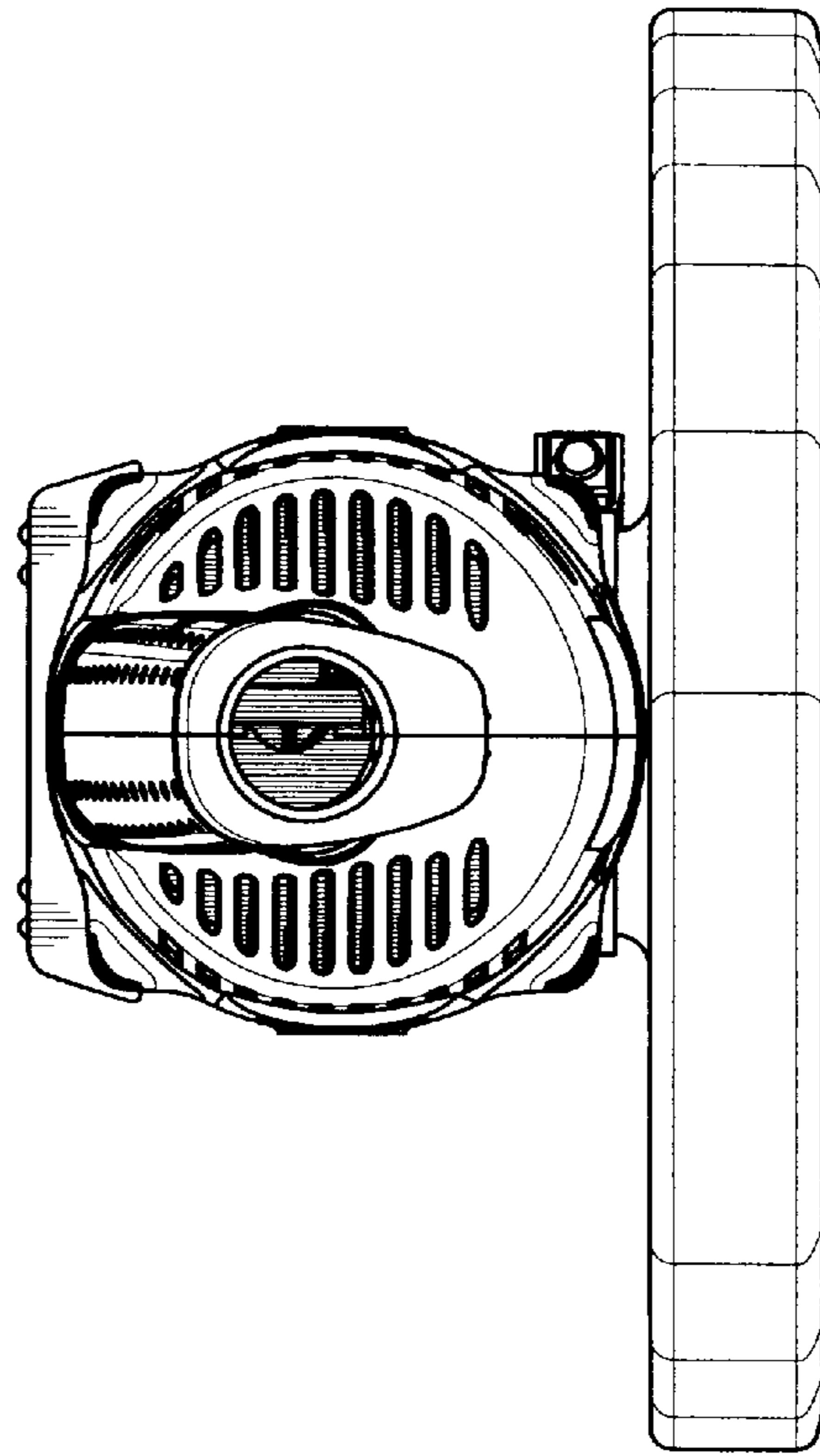

FIG. 5

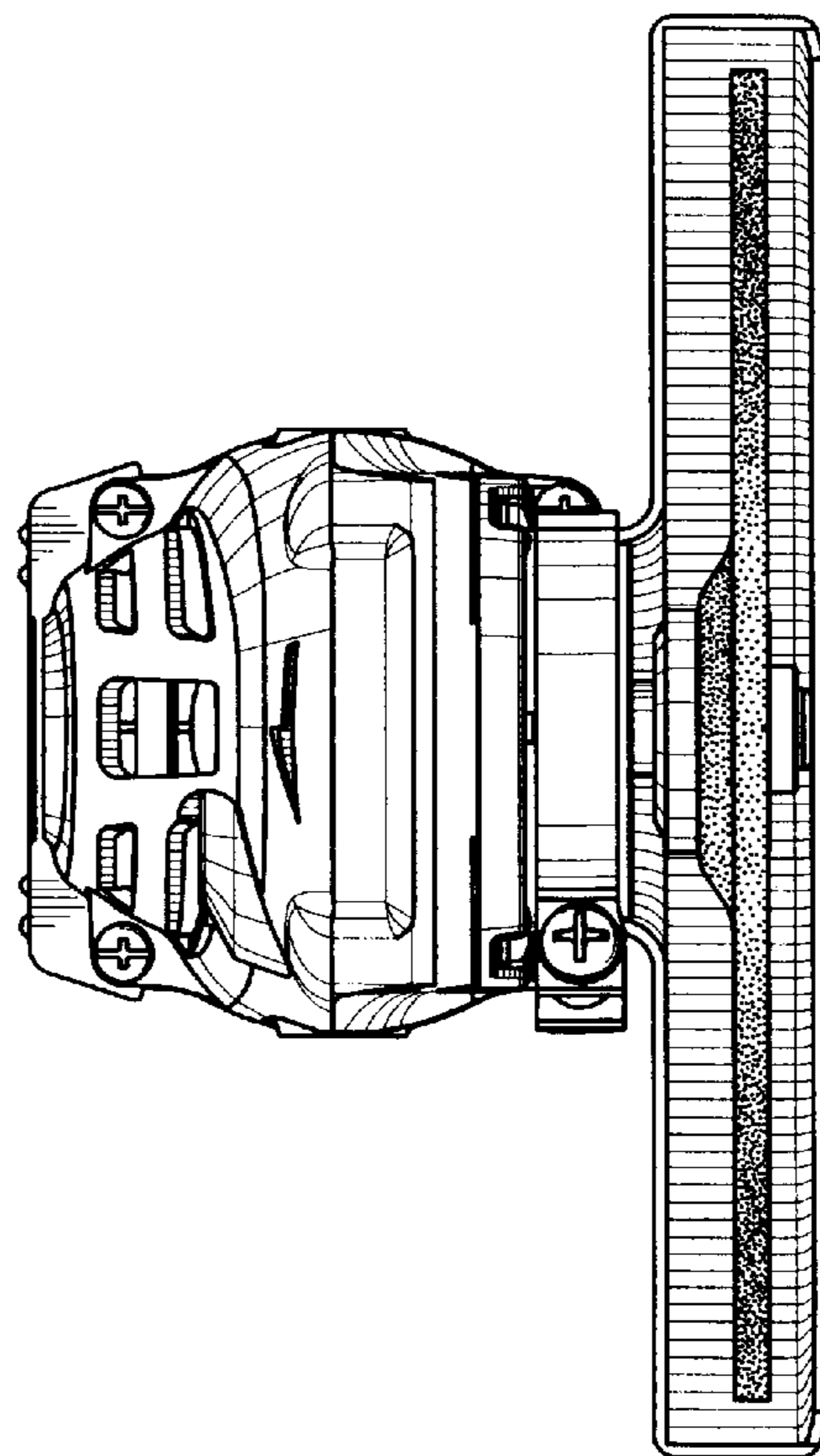

FIG. 4

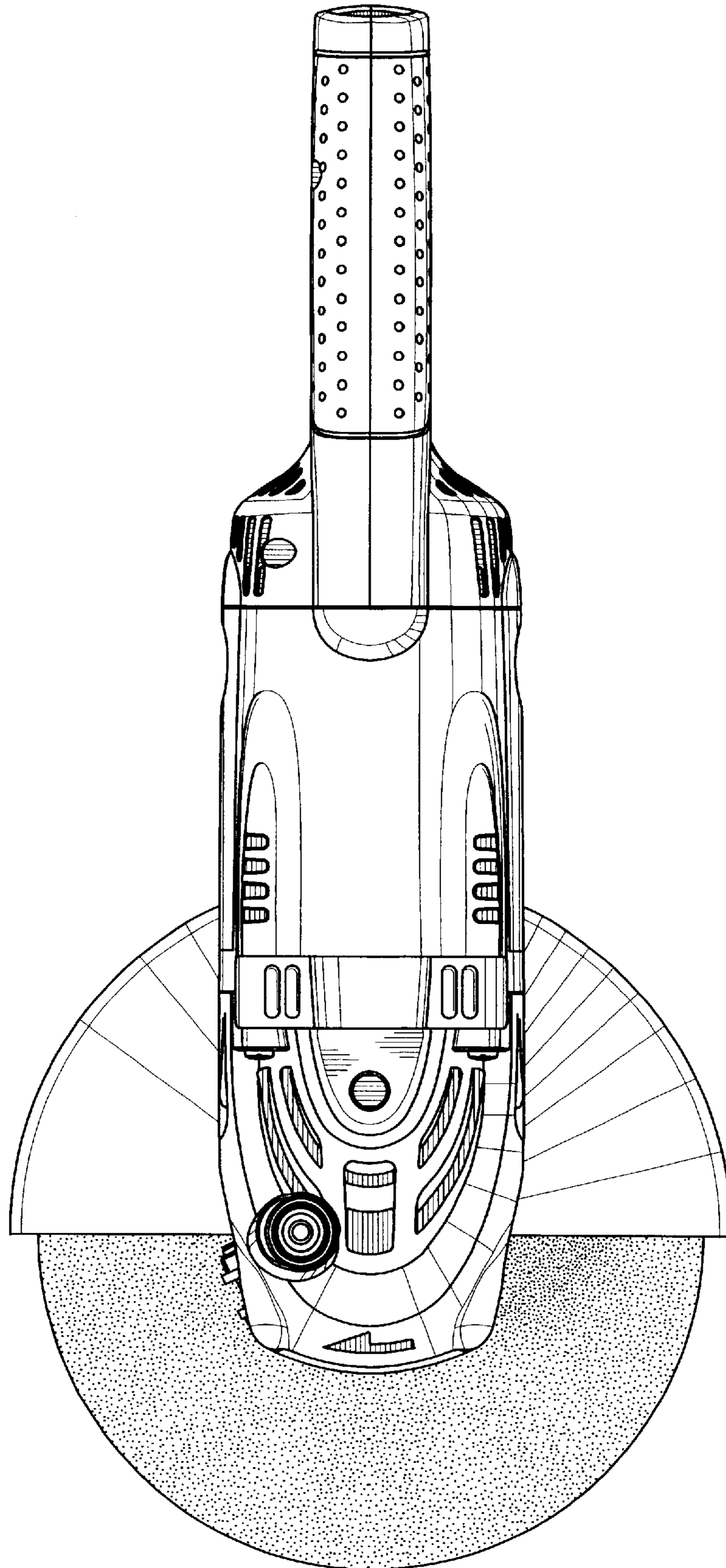

FIG. 6

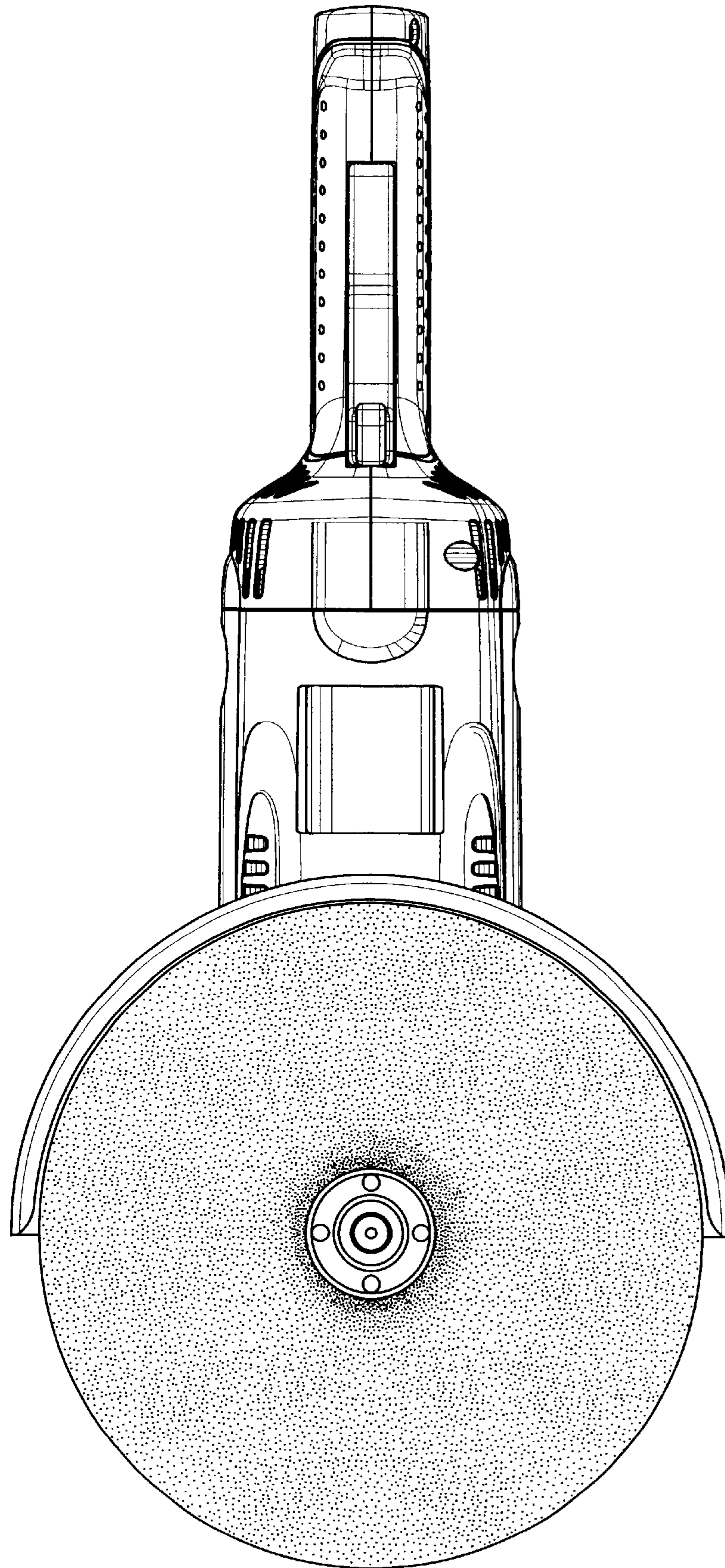

FIG. 7