

US00D521553S

(12) **United States Design Patent**  
**Sterman**

(10) **Patent No.:** **US D521,553 S**

(45) **Date of Patent:** **\*\* May 23, 2006**

(54) **PLANAR DOOR KEY AND ADVERTISING FOLDER**

(75) Inventor: **Marc W. Sterman**, Latham, NY (US)

(73) Assignee: **Target Marketing Systems, Inc.**, Albany, NY (US)

(\*\*) Term: **14 Years**

(21) Appl. No.: **29/208,385**

(22) Filed: **Jun. 29, 2004**

(51) **LOC (8) Cl.** ..... **19-01**

(52) **U.S. Cl.** ..... **D19/2**

(58) **Field of Classification Search** ..... D9/433;  
D19/1-8; 40/124.01-124.18, 360, 539, 672;  
206/215; 229/68.1, 71, 75, 76, 92.5, 92.7,  
229/92.8, 300, 313, 87.5; 281/2, 5, 38, 51;  
283/56, 61, 62, 106, 116, 117; 493/216

See application file for complete search history.

(56) **References Cited**

**U.S. PATENT DOCUMENTS**

202,874	A	*	4/1878	Rogers	.....	229/92.7
311,915	A	*	2/1885	Pedrick	.....	229/92.7
830,354	A	*	9/1906	McDonald	.....	229/92.3
1,134,082	A	*	3/1915	Valasek	.....	229/92.3
1,794,223	A	*	2/1931	Zabek	.....	229/92.1
2,149,030	A	*	2/1939	Moore	.....	229/76
2,453,902	A	*	11/1948	Graham	.....	40/752
2,631,046	A	*	3/1953	Stephens	.....	283/56
2,690,625	A	*	10/1954	Dazey	.....	206/215
2,983,431	A	*	5/1961	Turan	.....	229/92.3
3,303,987	A	*	2/1967	Caine	.....	229/92.8
4,044,942	A	*	8/1977	Sherwood	.....	229/305
4,428,526	A	*	1/1984	Riley	.....	229/92.8
4,653,639	A	*	3/1987	Traynor	.....	206/308.3
5,125,689	A	*	6/1992	Heninger	.....	283/106
5,487,566	A	*	1/1996	Hedge, Jr.	.....	283/56

5,603,529	A	*	2/1997	Breindel	.....	283/56
5,622,390	A	*	4/1997	Jenkins	.....	283/116
D400,919	S	*	11/1998	Pickel	.....	D19/1
6,106,023	A	*	8/2000	Sud et al.	.....	283/117
6,557,748	B1	*	5/2003	Bethke	.....	229/92.1
6,644,538	B1	*	11/2003	Schnitzer	.....	229/74
2002/0157356	A1	*	10/2002	Gerrie	.....	53/460
2002/0195816	A1	*	12/2002	Anise	.....	283/106
2004/0080152	A1	*	4/2004	Houston	.....	283/36
2005/0001021	A1	*	1/2005	Hutchinson	.....	229/300
2005/0006448	A1	*	1/2005	Bethke	.....	229/300

\* cited by examiner

*Primary Examiner*—Janice E. Seeger

*Assistant Examiner*—Elizabeth Albert

(74) *Attorney, Agent, or Firm*—Authur G. Yeager

(57) **CLAIM**

I claim the ornamental design for planar door key and advertising folder, as shown and described.

**DESCRIPTION**

FIG. 1 is a top perspective view of a planar door key and advertising folder in unfolded condition showing my new design with the broken lines representing crease lines;

FIG. 2 is a rear elevational view thereof in its flattened condition with the broken lines representing crease lines;

FIG. 3 is a front elevational view thereof;

FIG. 4 is a top plan view thereof in folded condition;

FIG. 5 is a bottom plan view thereof in folded condition; and,

FIG. 6 is a top plan view thereof in unfolded condition, the bottom plan view in unfolded condition being the mirror image thereof.

The broken lines showing environment in the drawings are for information purposes only and form no part of the claimed design.

**1 Claim, 3 Drawing Sheets**

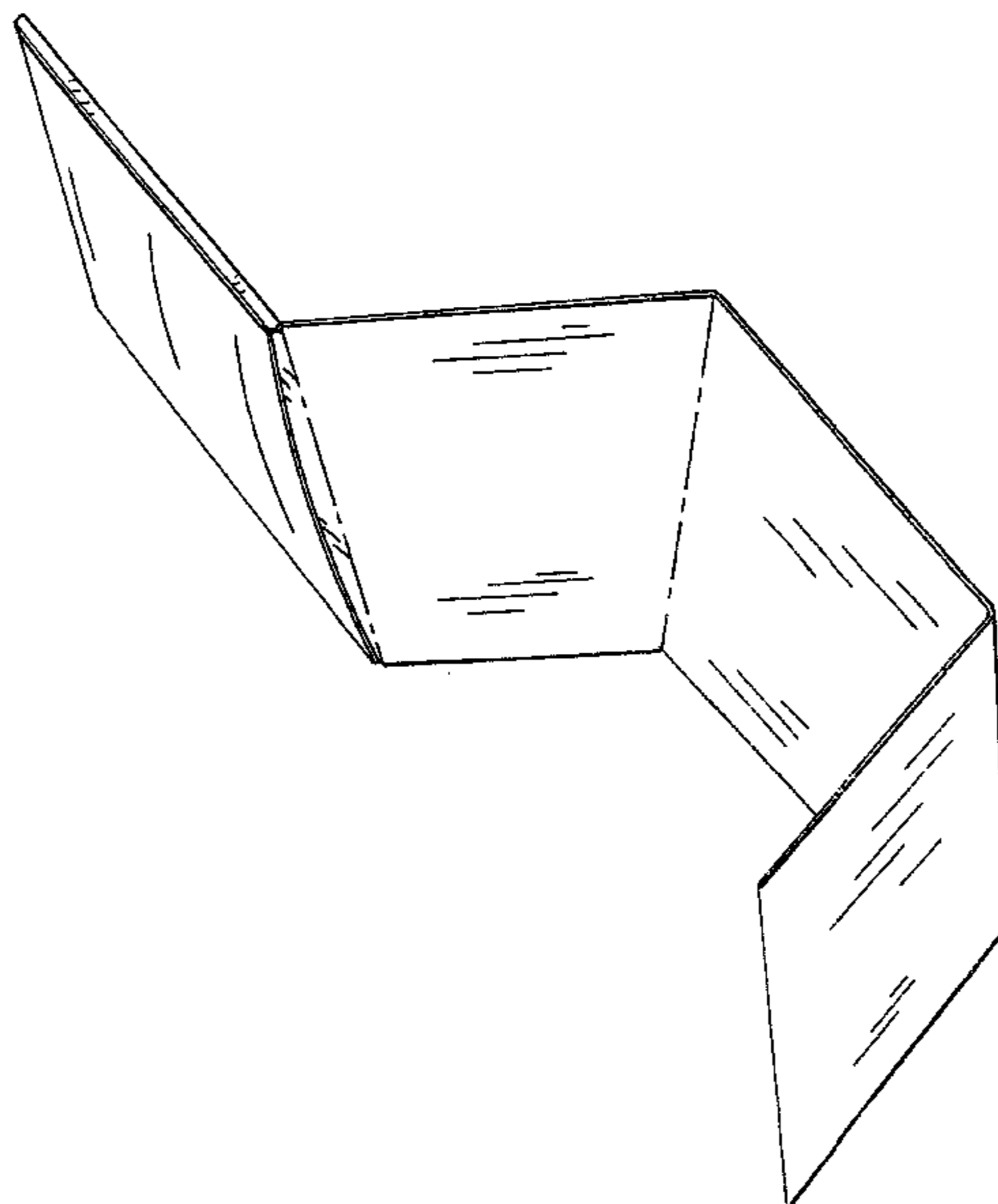

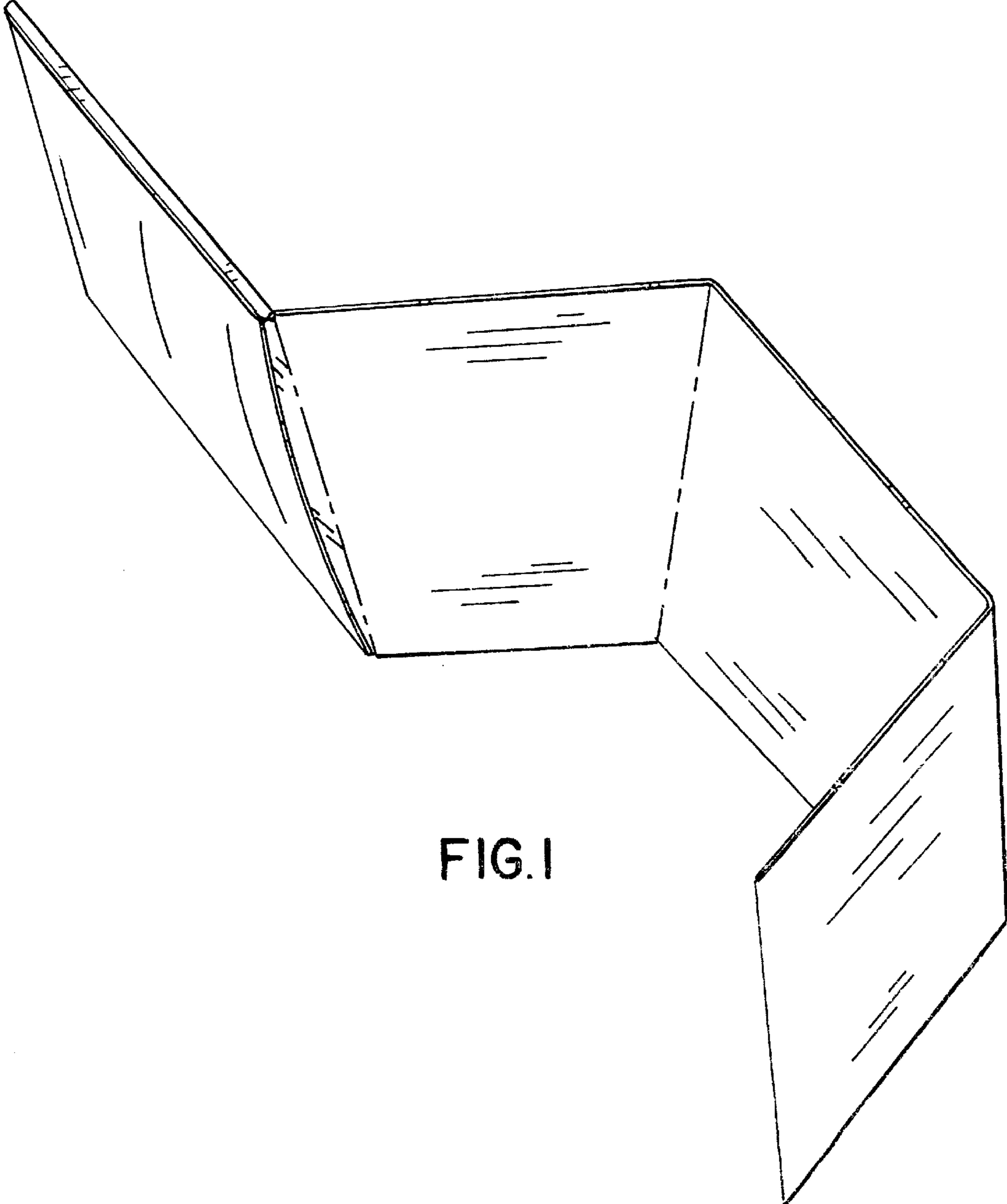

FIG. 1

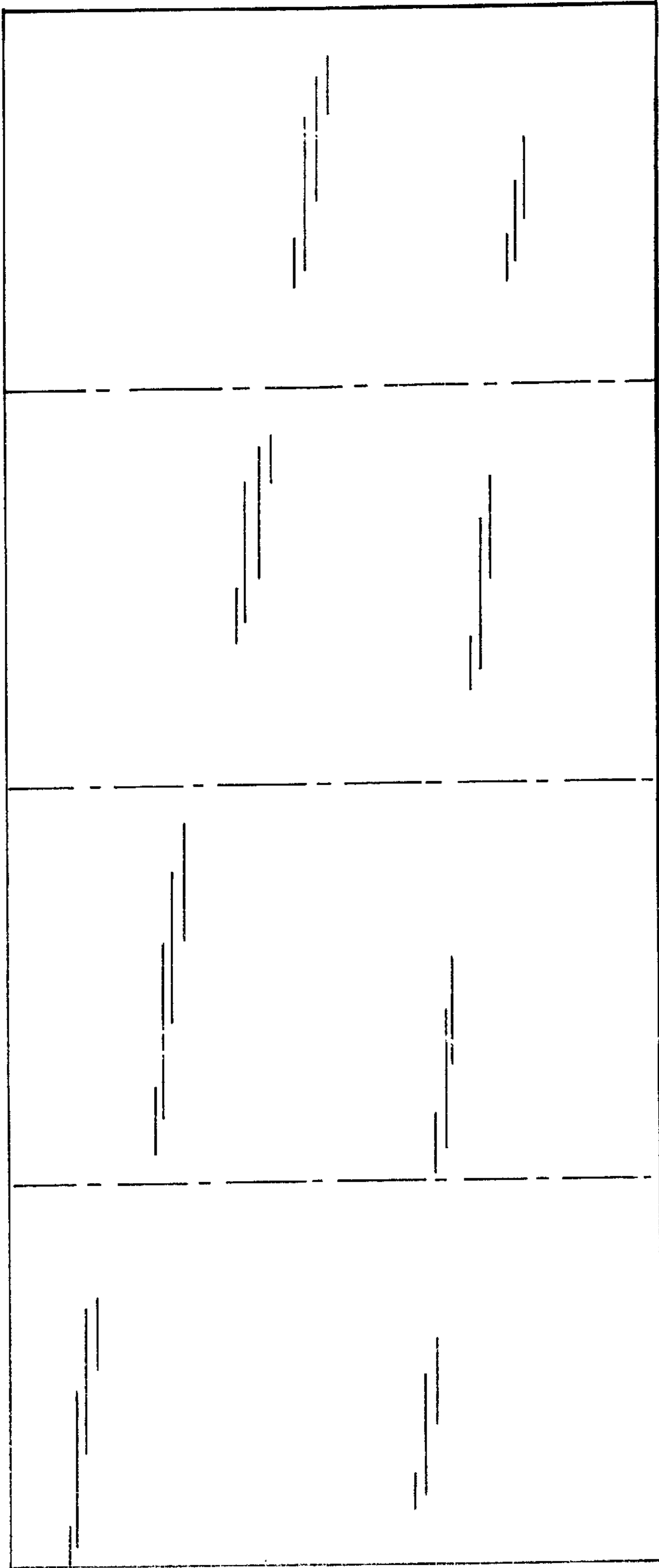

FIG. 2



FIG. 5



FIG. 4

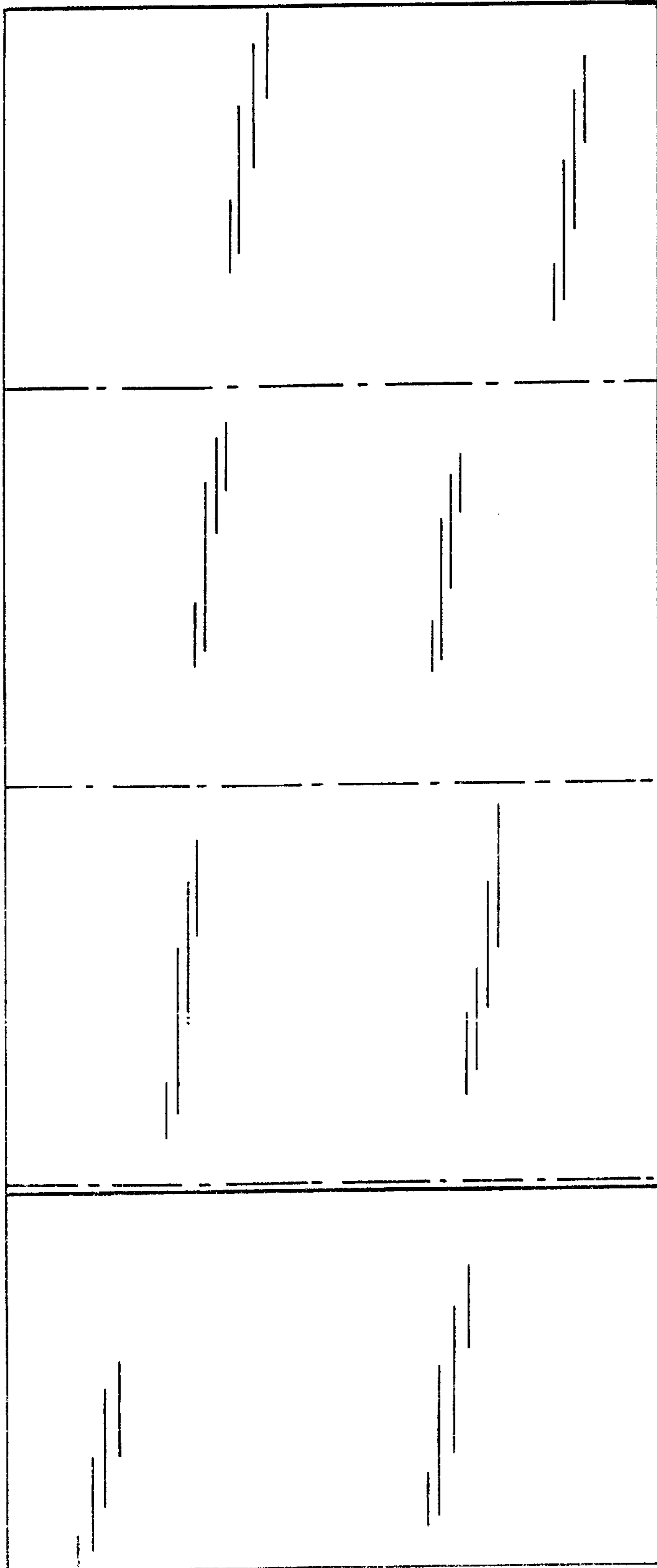

FIG. 3



FIG. 6