

US00D521496S

(12) **United States Design Patent**
Sogabe

(10) **Patent No.:** **US D521,496 S**
(45) **Date of Patent:** **** May 23, 2006**

(54) **SPEAKER BOX**

(75) Inventor: **Takashi Sogabe**, Tokyo (JP)
(73) Assignee: **Sony Corporation**, Tokyo (JP)
(**) Term: **14 Years**

(21) Appl. No.: **29/223,464**
(22) Filed: **Feb. 15, 2005**

(51) **LOC (8) Cl.** **14-01**
(52) **U.S. Cl.** **D14/214; D14/215**
(58) **Field of Classification Search** D14/204,
D14/207, 209–216, 356; 181/143–144, 147–148,
181/150, 157, 198–199, 151, 153; 381/300–302,
381/306, 333, 345, 361–364, 386–388, 332,
381/336

See application file for complete search history.

(56) **References Cited**

U.S. PATENT DOCUMENTS

D417,874 S	*	12/1999	Suzuki	D14/214
D418,511 S		1/2000	Suzuki		
D434,751 S		12/2000	Sogabe et al.		
D448,753 S		10/2001	Masui		
6,385,326 B1	*	5/2002	Peng	381/386
D460,958 S		7/2002	Suzuki		
D468,290 S	*	1/2003	Narita	D14/214
D480,707 S	*	10/2003	Bolton et al.	D14/214

OTHER PUBLICATIONS

Web page “MM-SPSW6” <http://www.yodobashi.com/enjoy/more/i/7066348.html>, 1 sheet, Yodobashi Camera (Dec. 2004).
Web page “SC-HT03-S” http://www8.yodobashi.com/enjoy/more/i/cat_1045_430_25356041_25356141/22468378.html, 1 sheet, Yodobashi Camera (Dec. 2004).
Web page “Acoustimas AM-5111” http://www.bose.co.jp/home_audio/ht_speakers/am5_3.html, 1 sheet, BOSE K.K. (Dec. 2004).

* cited by examiner

Primary Examiner—Nanda Bondade
(74) *Attorney, Agent, or Firm*—Rader, Fishman & Grauer PLLC

(57) **CLAIM**

The ornamental design for a speaker box, as shown.

DESCRIPTION

FIG. 1 is a perspective view of a speaker box showing my new design;
FIG. 2 is a front elevational view thereof;
FIG. 3 is a rear elevational view thereof;
FIG. 4 is a left side elevational view thereof;
FIG. 5 is a right side elevational view thereof;
FIG. 6 is a top plan view thereof; and,
FIG. 7 is a bottom plan view thereof.

1 Claim, 4 Drawing Sheets

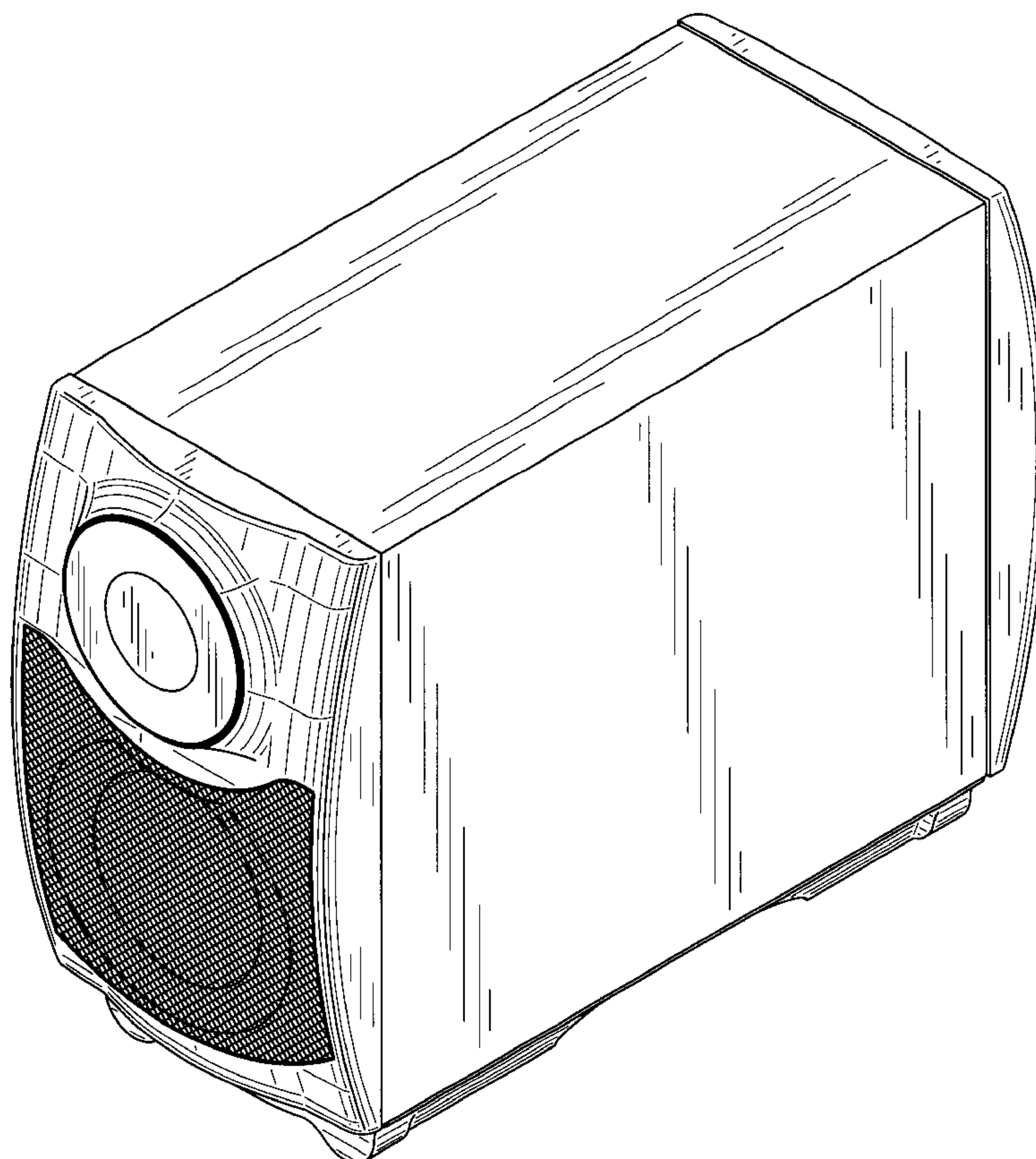

Fig.1

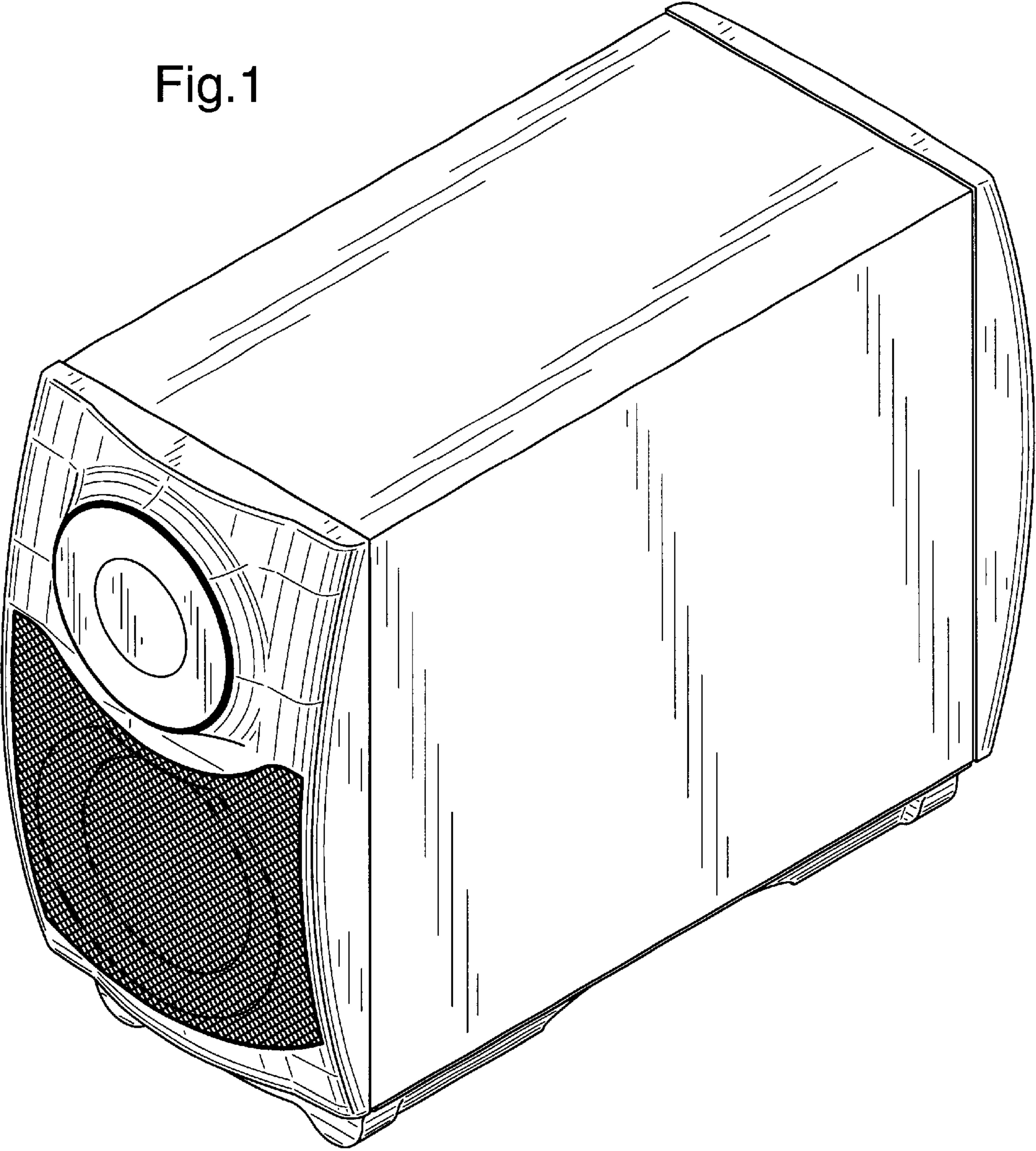

Fig.2

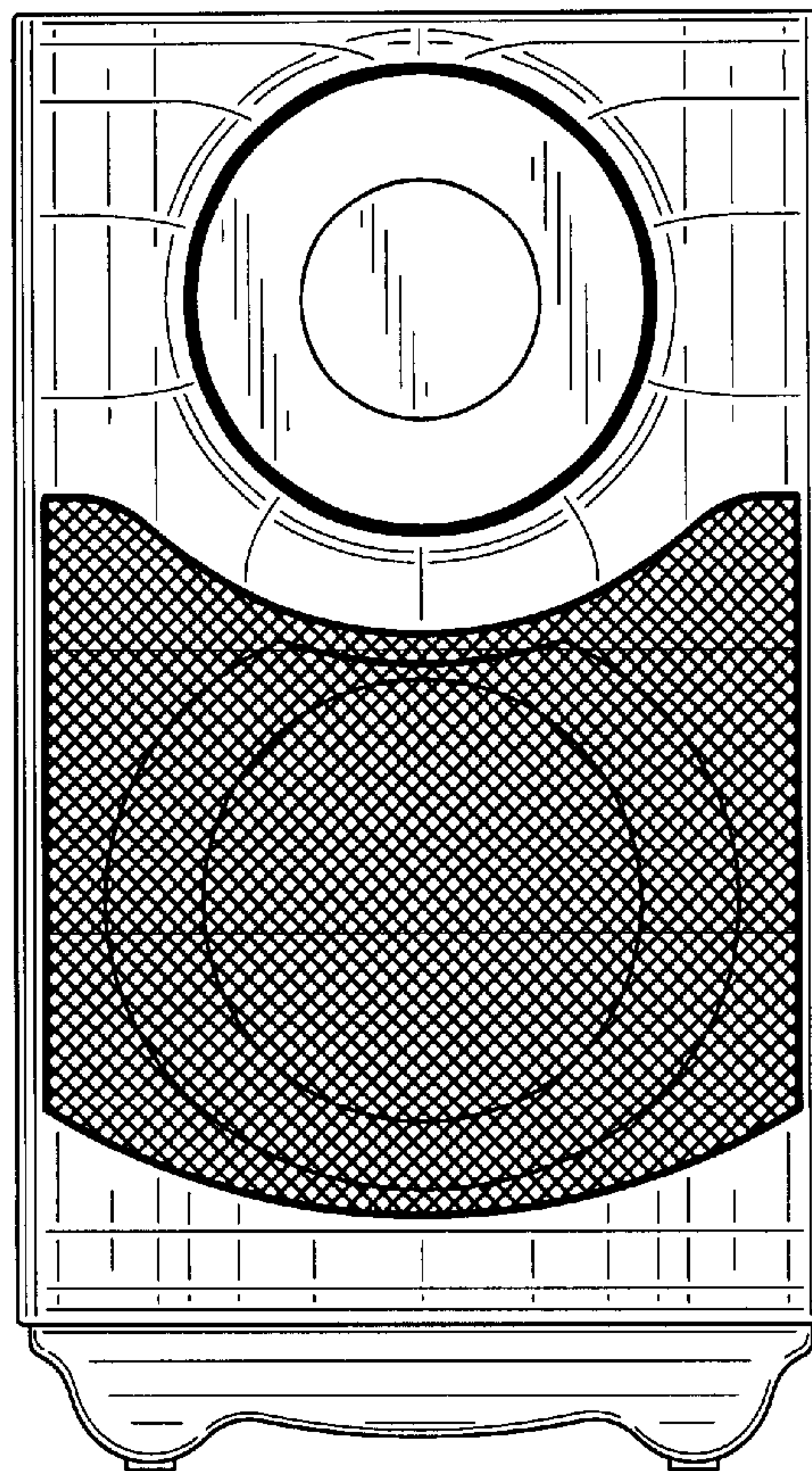

Fig.3

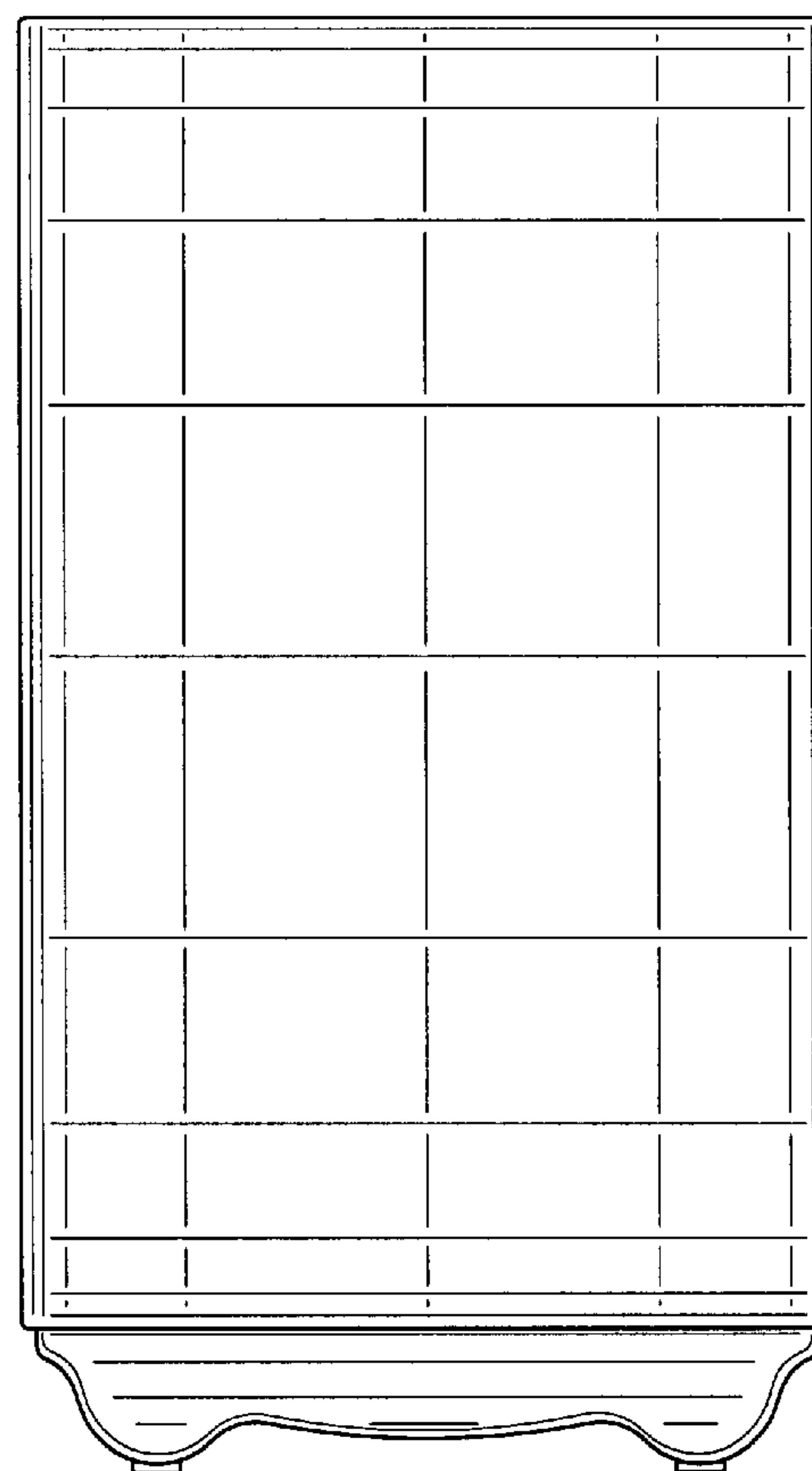

Fig.4

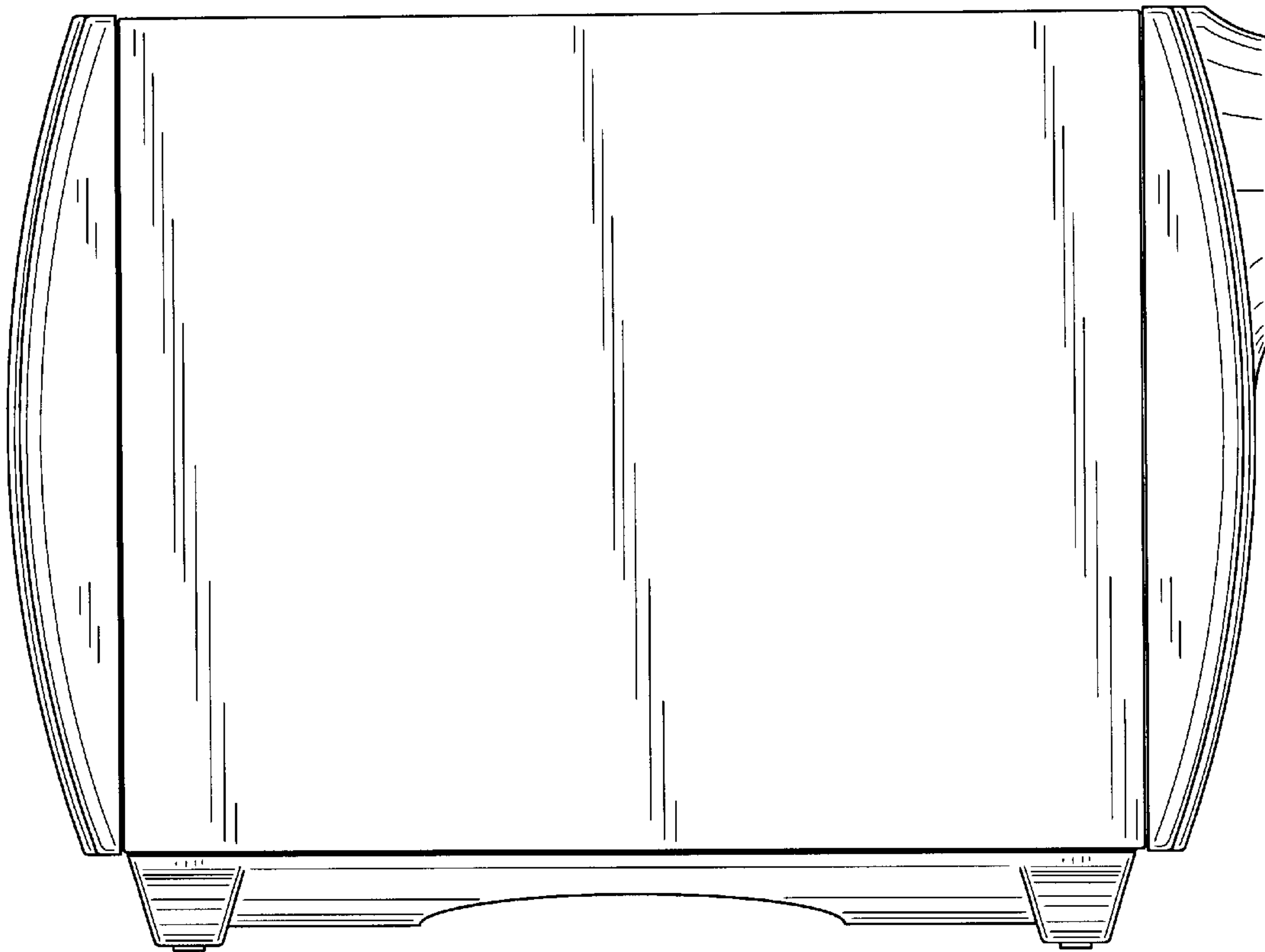

Fig.5

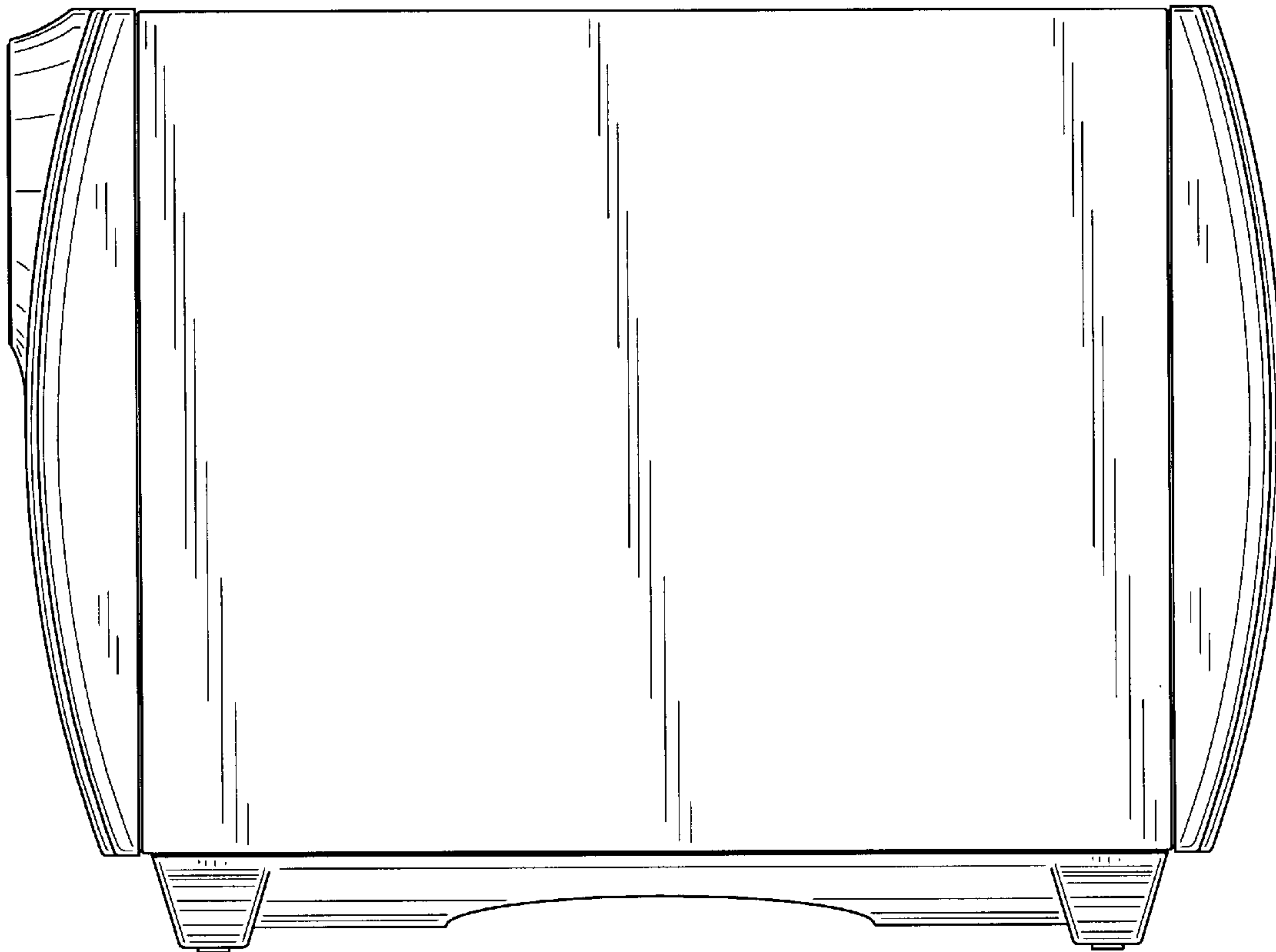

Fig.6

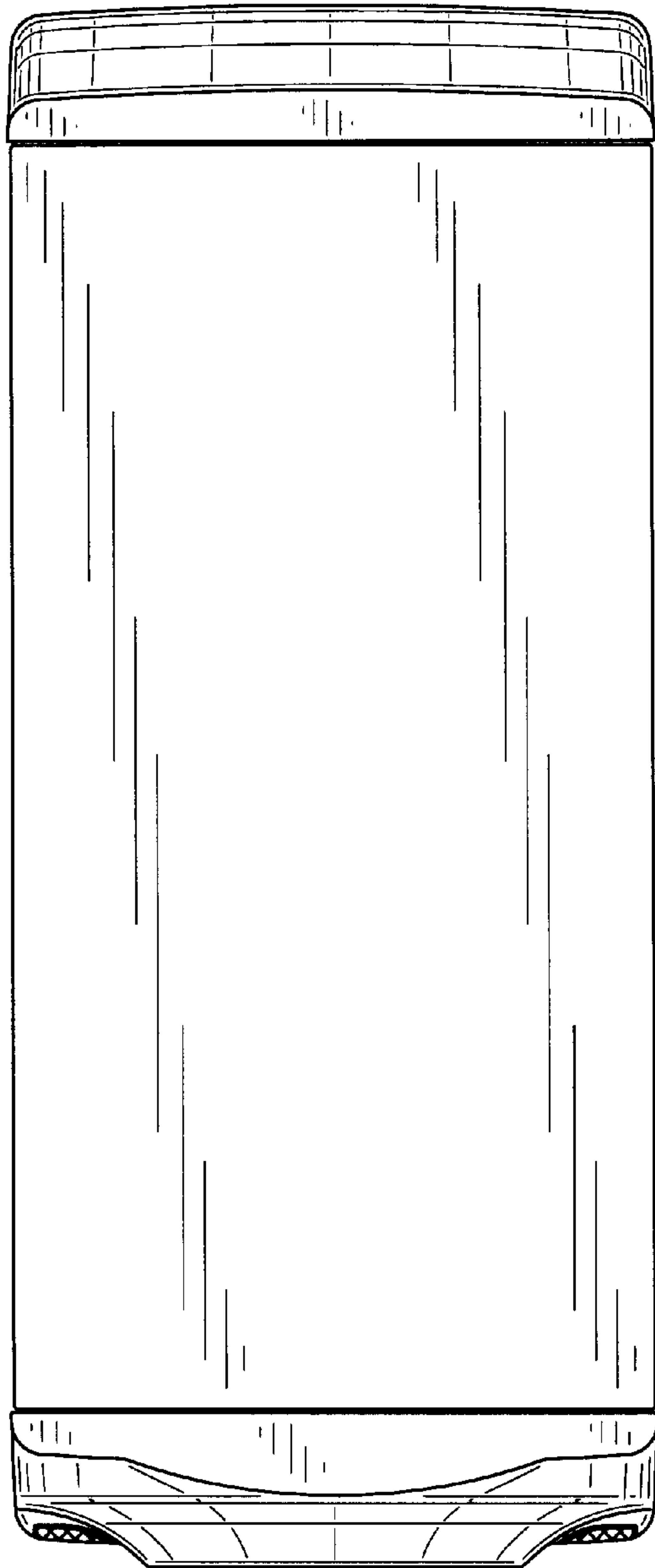

Fig.7

