

US00D521033S

(12) **United States Design Patent**
Sakamoto et al.

(10) **Patent No.:** **US D521,033 S**

(45) **Date of Patent:** **** May 16, 2006**

(54) **INNER STAMPER HOLDER FOR A DISC-MOLDING DIE**

5,693,348 A * 12/1997 Sakamoto et al. 425/436 R
5,987,003 A * 11/1999 Yokota 369/280

(75) Inventors: **Yasuyoshi Sakamoto**, Kamagaya (JP);
Katsuyuki Hiki, Narashino (JP)

* cited by examiner

(73) Assignee: **Seikoh Giken Co., Ltd.**, Chiba (JP)

Primary Examiner—Antoine D. Davis

Assistant Examiner—Patricia Palasik

(**) Term: **14 Years**

(74) *Attorney, Agent, or Firm*—Olson & Hierl, Ltd.

(21) Appl. No.: **29/217,441**

(57) **CLAIM**

(22) Filed: **Nov. 17, 2004**

The ornamental design for an inner stamper holder for a disc-molding die, as shown and described.

(51) **LOC (8) Cl.** **15-09**

DESCRIPTION

(52) **U.S. Cl.** **D15/135**

(58) **Field of Classification Search** D15/135-137;
369/280; 360/135; 425/436 R, 588, 589;
264/1.33, 107, 328.8

FIG. 1 is a perspective view of an inner stamper holder for a disc-molding die;

FIG. 2 is a front view thereof;

FIG. 3 is a right side view thereof, a left side view being a mirror view of the right side view;

FIG. 4 is a top plan view thereof;

FIG. 5 is a bottom view thereof; and,

FIG. 6 is a sectional view taken along line 6—6 thereof.

See application file for complete search history.

(56) **References Cited**

U.S. PATENT DOCUMENTS

4,971,548 A * 11/1990 Asai 425/588

1 Claim, 3 Drawing Sheets

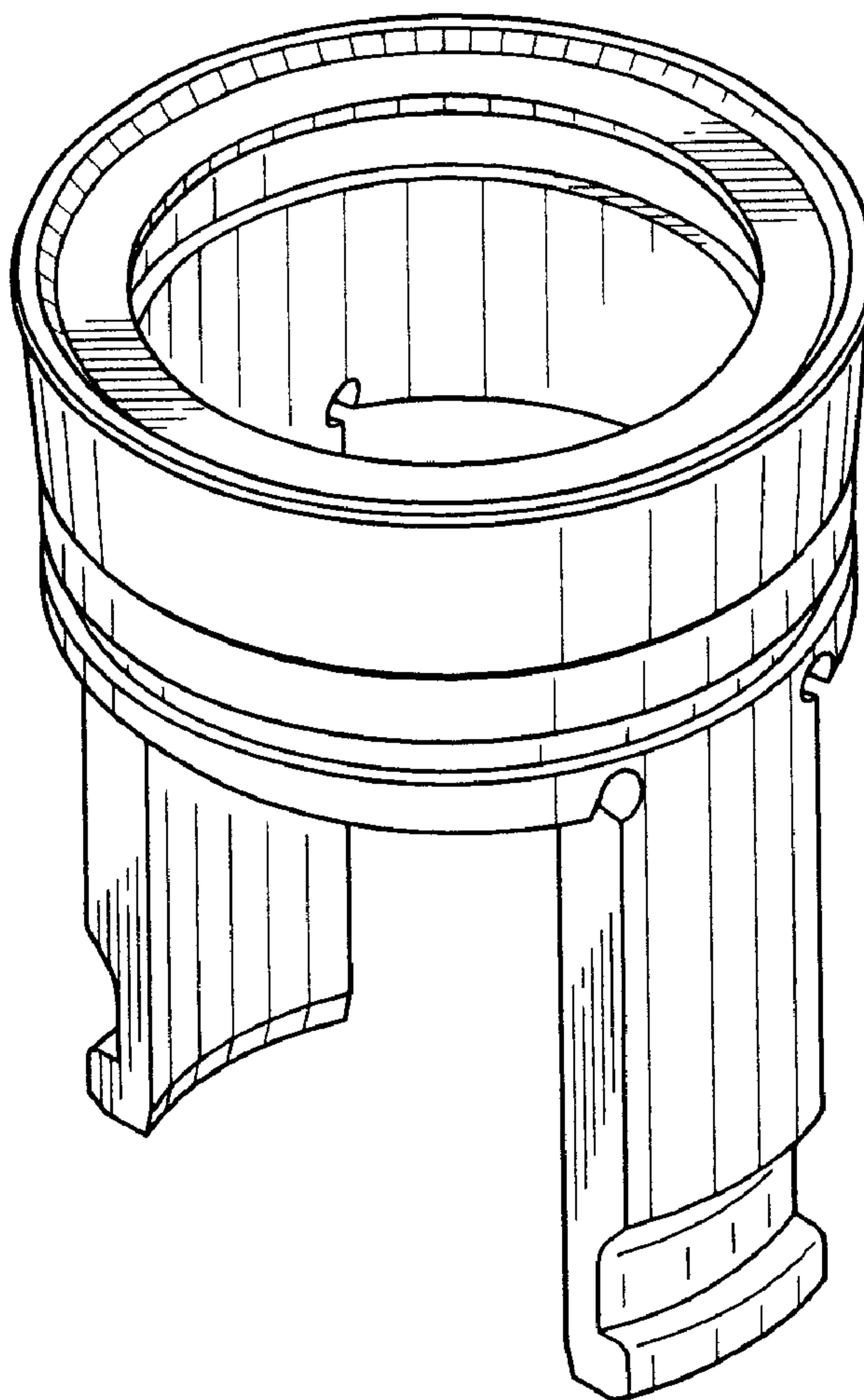

FIG. 1

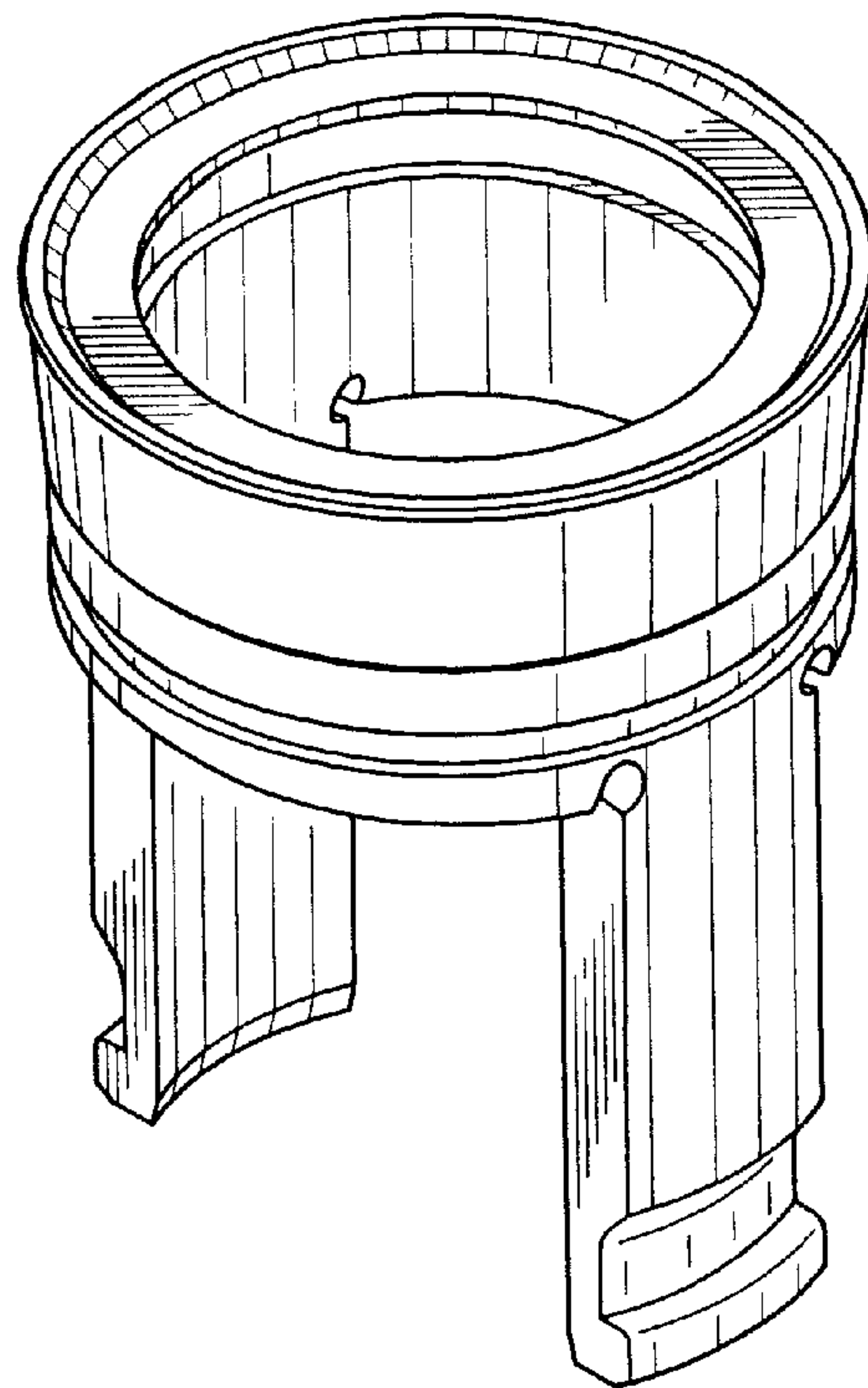

FIG. 2

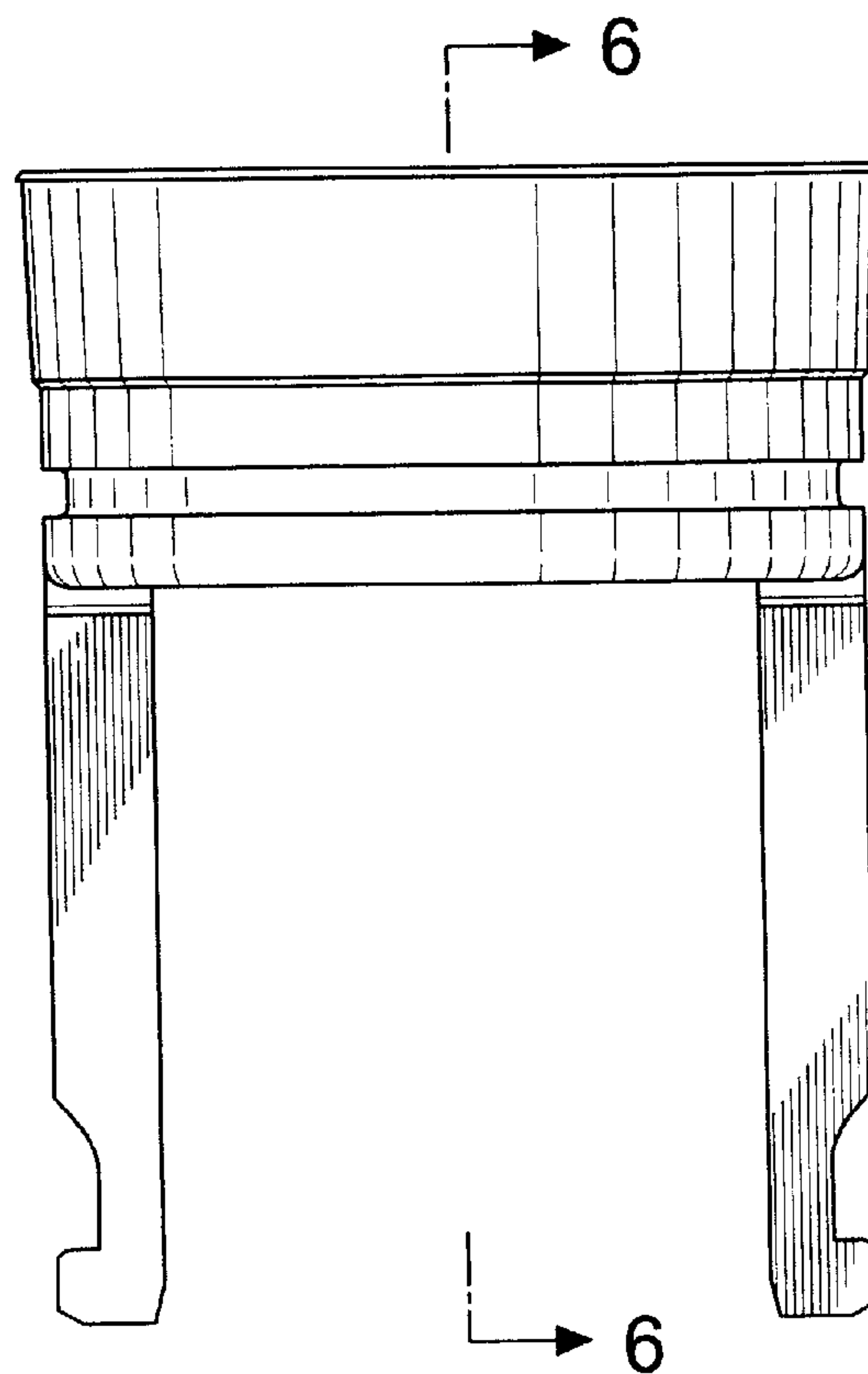

FIG.3

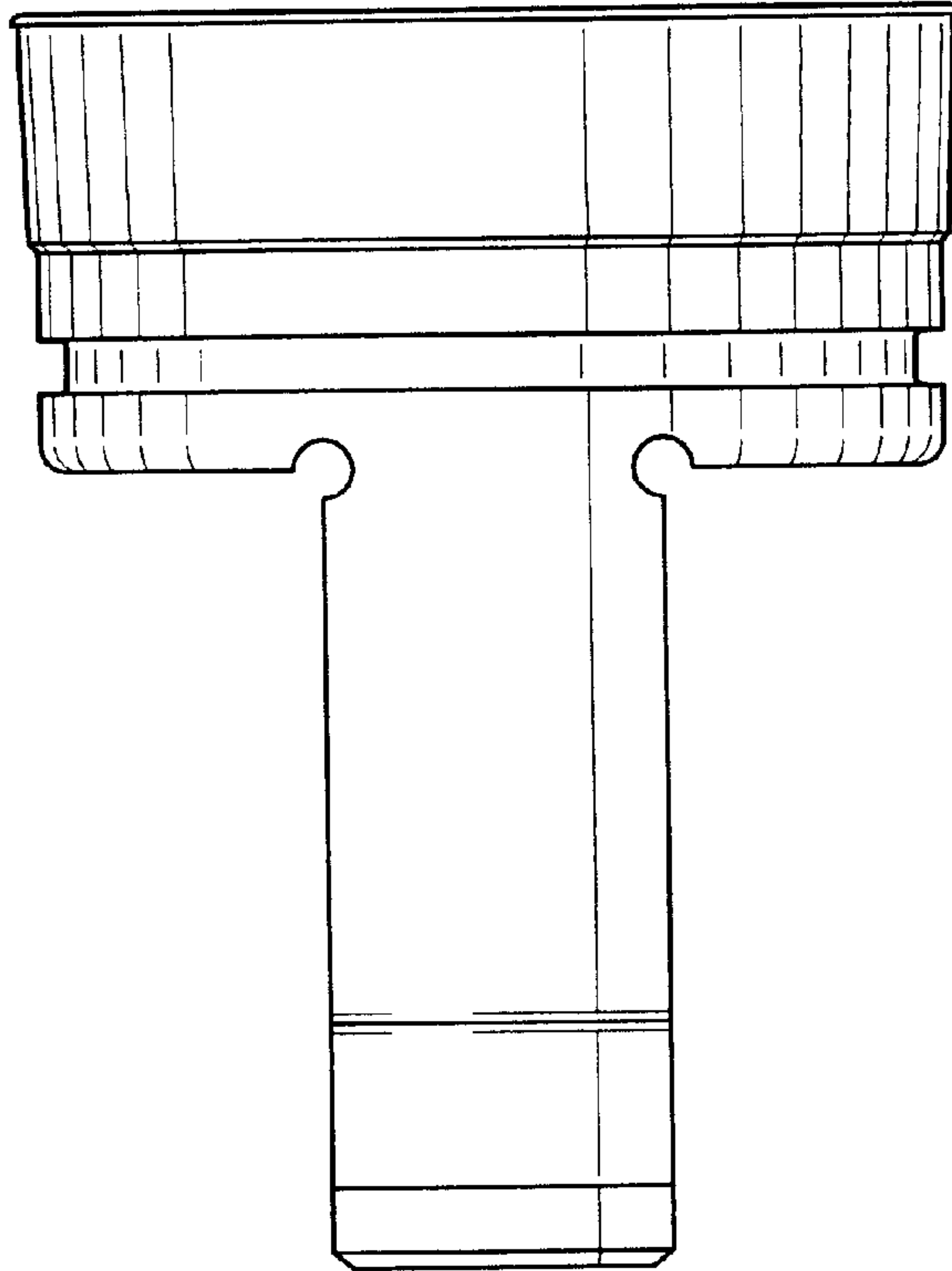

FIG.4

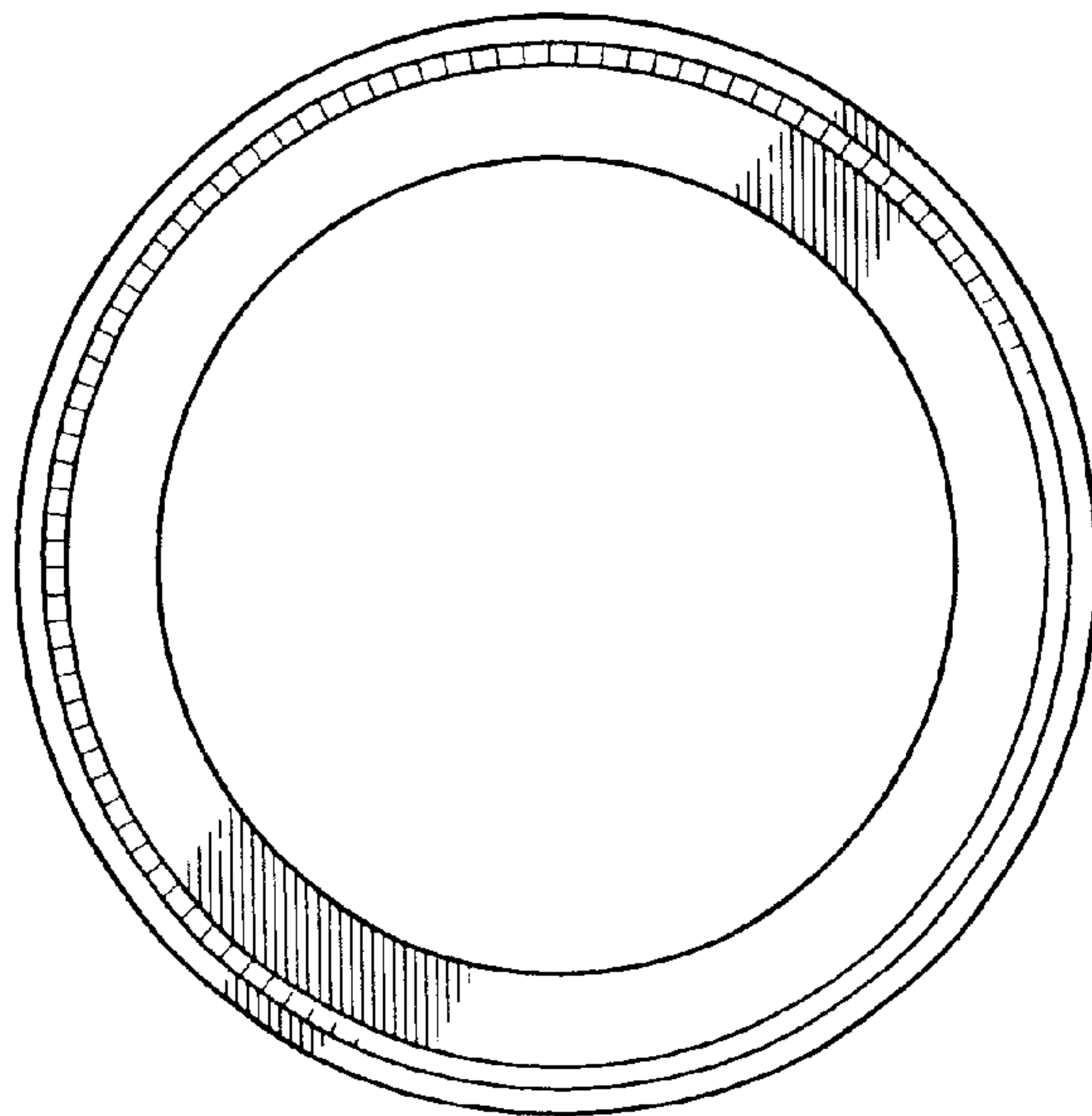

FIG.5

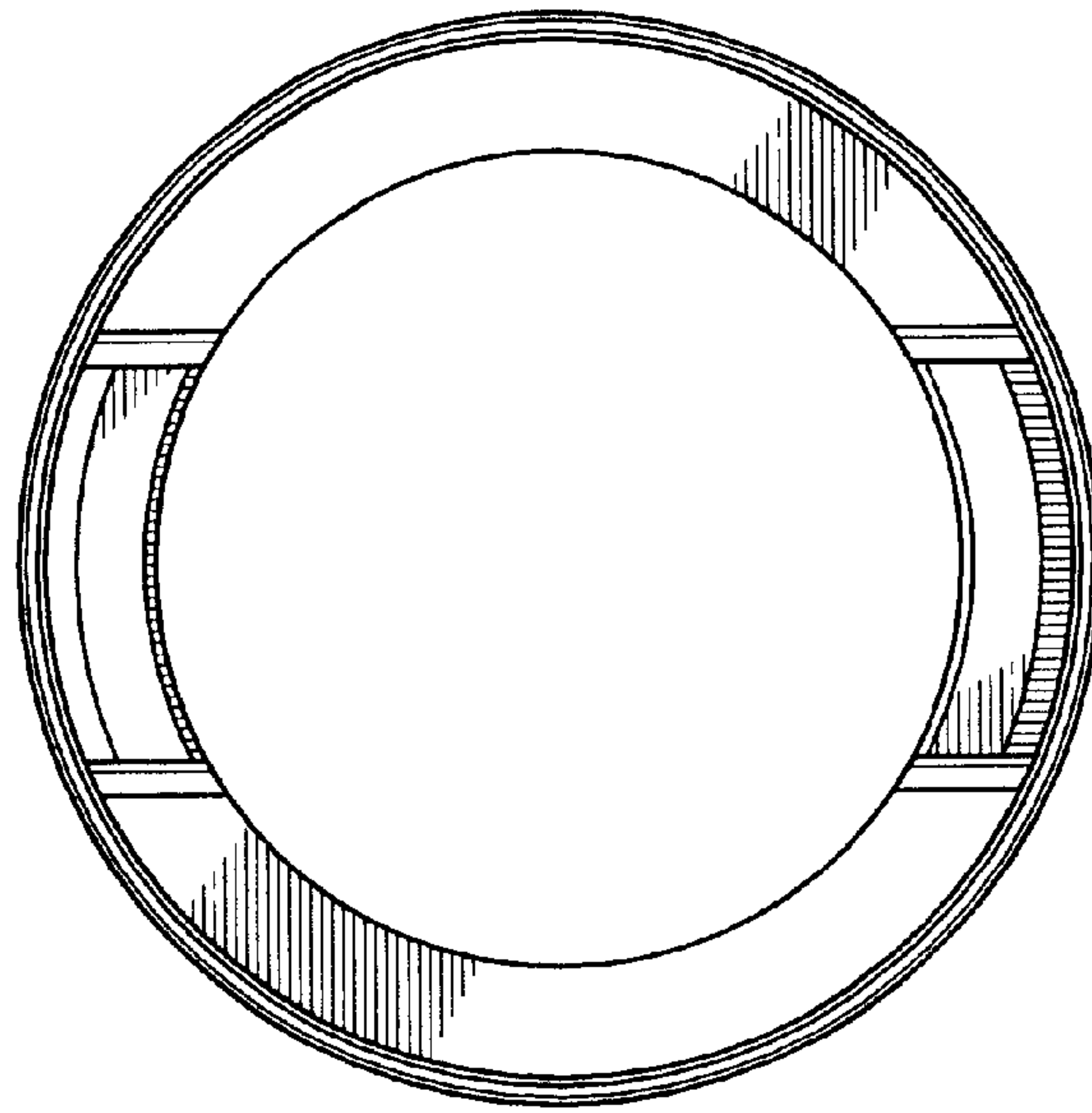

FIG.6

