



US00D520417S

(12) **United States Design Patent**
Yagi et al.

(10) **Patent No.:** **US D520,417 S**

(45) **Date of Patent:** **** May 9, 2006**

(54) **FRONT BUMPER FOR AN AUTOMOBILE**

(75) Inventors: **Masaaki Yagi**, Aichi-ken (JP); **Yuji Yamanashi**, Aichi-ken (JP)

(73) Assignee: **Toyota Jidosha Kabushiki Kaisha**, Aichi-ken (JP)

(**) Term: **14 Years**

(21) Appl. No.: **29/227,235**

(22) Filed: **Apr. 8, 2005**

(51) **LOC (8) Cl.** **12-16**

(52) **U.S. Cl.** **D12/169**

(58) **Field of Classification Search** D12/90-92,
D12/86, 169, 196, 163; 296/180.1, 180.2;
293/102, 113, 115, 117, 120
See application file for complete search history.

(56) **References Cited**

U.S. PATENT DOCUMENTS

D472,856 S	*	4/2003	Oishi et al.	D12/169
D475,958 S	*	6/2003	Yokomaku	D12/196
D479,822 S	*	9/2003	Yokomaku	D12/196
D492,627 S	*	7/2004	Metros et al.	D12/169
D492,628 S	*	7/2004	Bond et al.	D12/169
D494,898 S	*	8/2004	Metros et al.	D12/169
D497,577 S	*	10/2004	Metros et al.	D12/169

OTHER PUBLICATIONS

Japanese magazine, "MotorFan," "Honda Step Wagan," special number "Minivan," Aug. 28, 2003, published by San-eishobo Publishing Co., Ltd.

Japanese magazine, "MotorFan," "Toyota Alphard," special number "Minivan," Aug. 28, 2003, published by San-eishobo Publishing Co., Ltd.

* cited by examiner

Primary Examiner—Melody N. Brown

(74) *Attorney, Agent, or Firm*—Finnegan, Henderson, Farabow, Garrett & Dunner, LLP

(57) **CLAIM**

The ornamental design for a front bumper for an automobile, as shown and described.

DESCRIPTION

FIG. 1 is a left-front, perspective view of a front bumper for an automobile of our new design:

FIG. 2 is a front view thereof;

FIG. 3 is a rear view thereof;

FIG. 4 is a top view thereof;

FIG. 5 is a bottom view thereof;

FIG. 6 is a right-side view of our new design, the left-side view being a mirror image thereof;

FIG. 7 is a cross-sectional view of our new design at 7—7 in FIG. 2;

FIG. 8 is a cross-sectional view of our new design at 8—8 in FIG. 2;

FIG. 9 is a cross-sectional view of our new design at 9—9 in FIG. 2; and,

FIG. 10 is a cross-sectional view of our new design at 10—10 in FIG. 6.

1 Claim, 5 Drawing Sheets

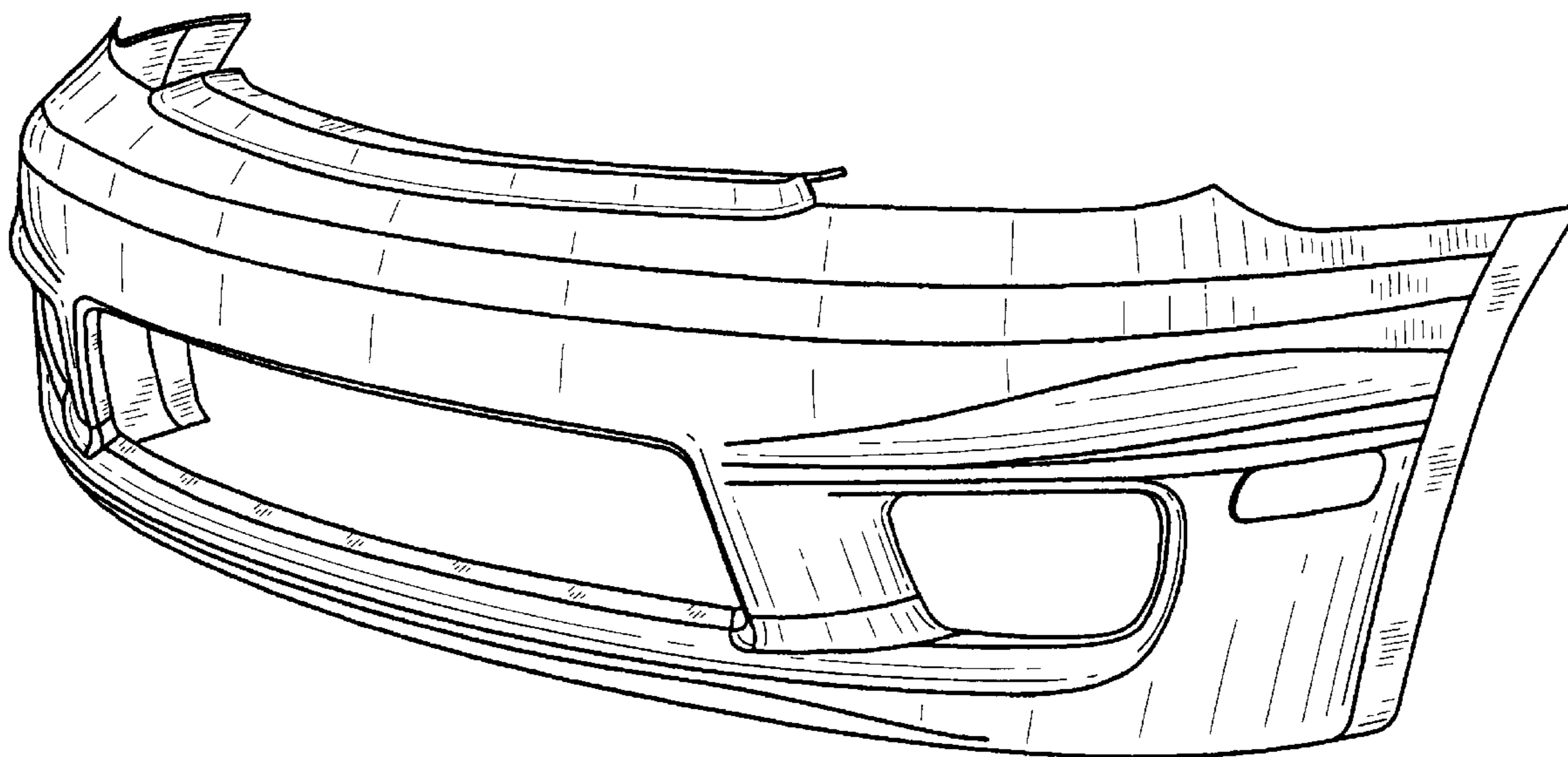

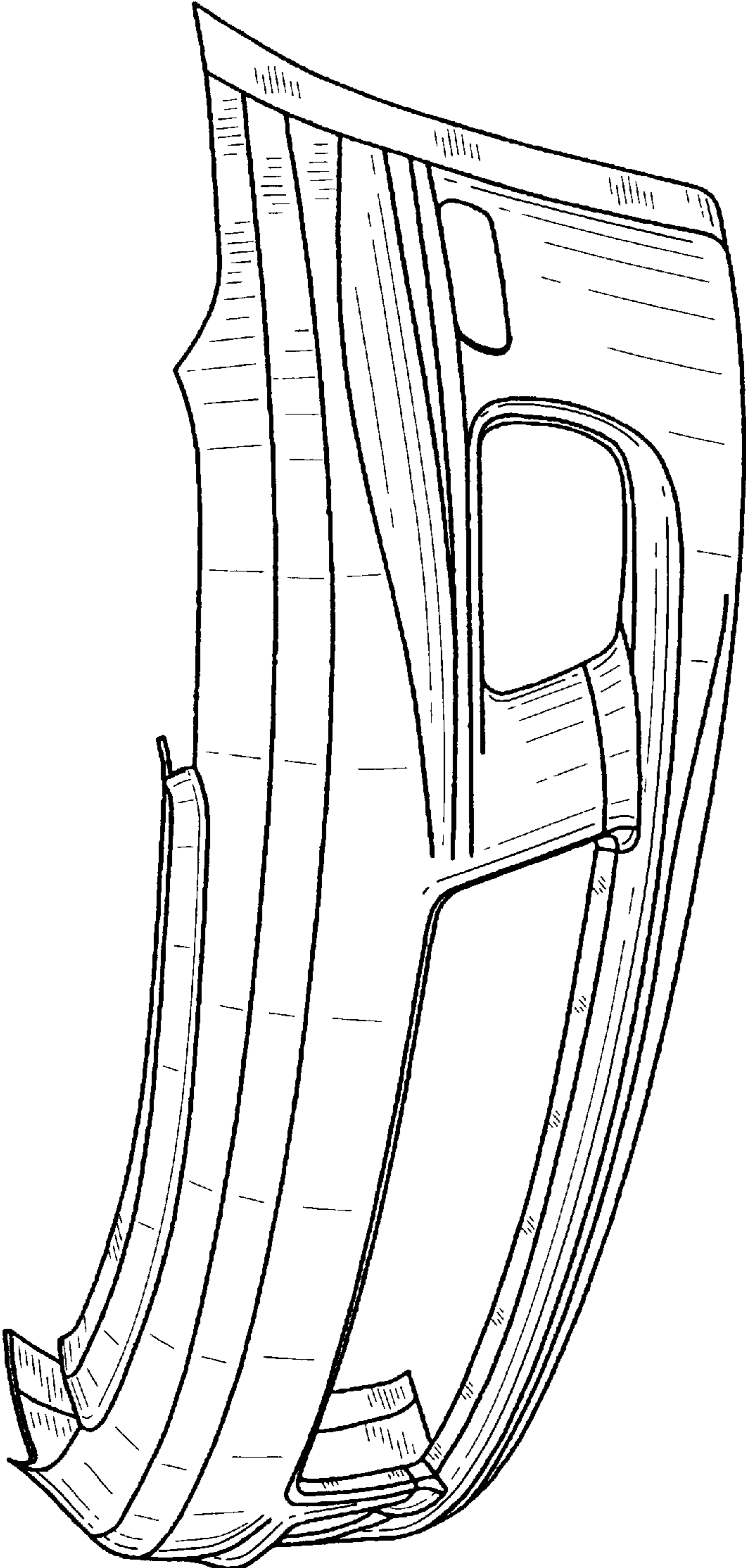

FIG. 1

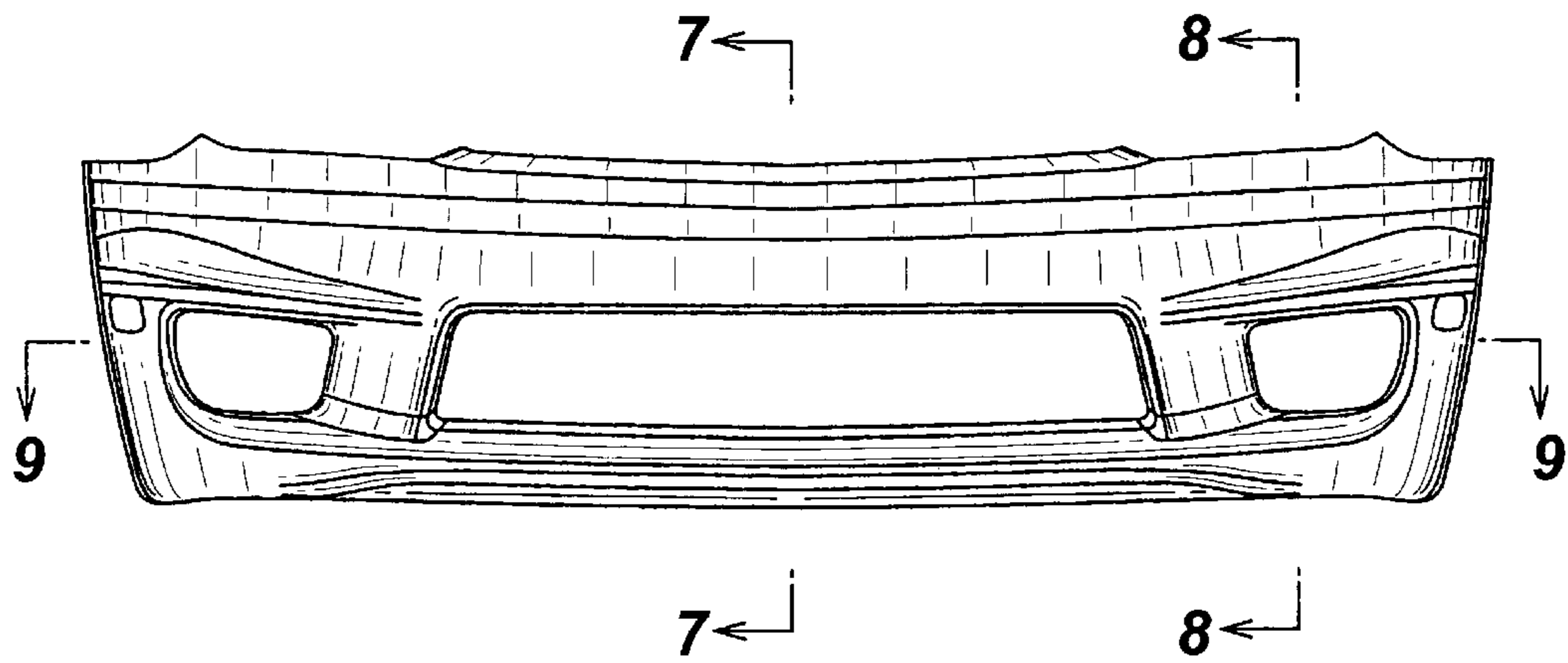

FIG. 2

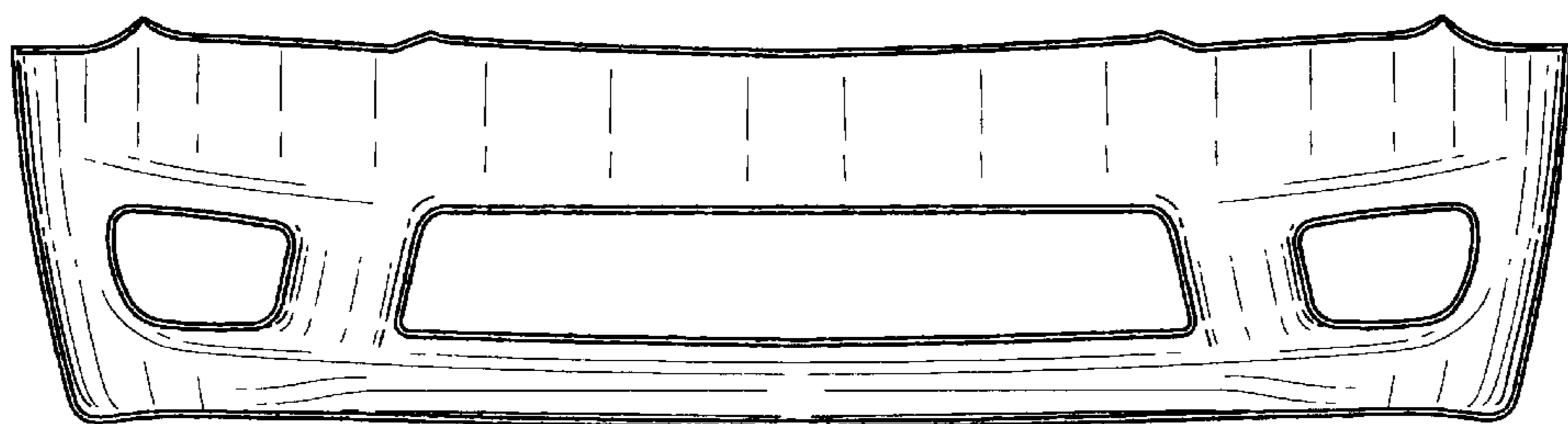

FIG. 3

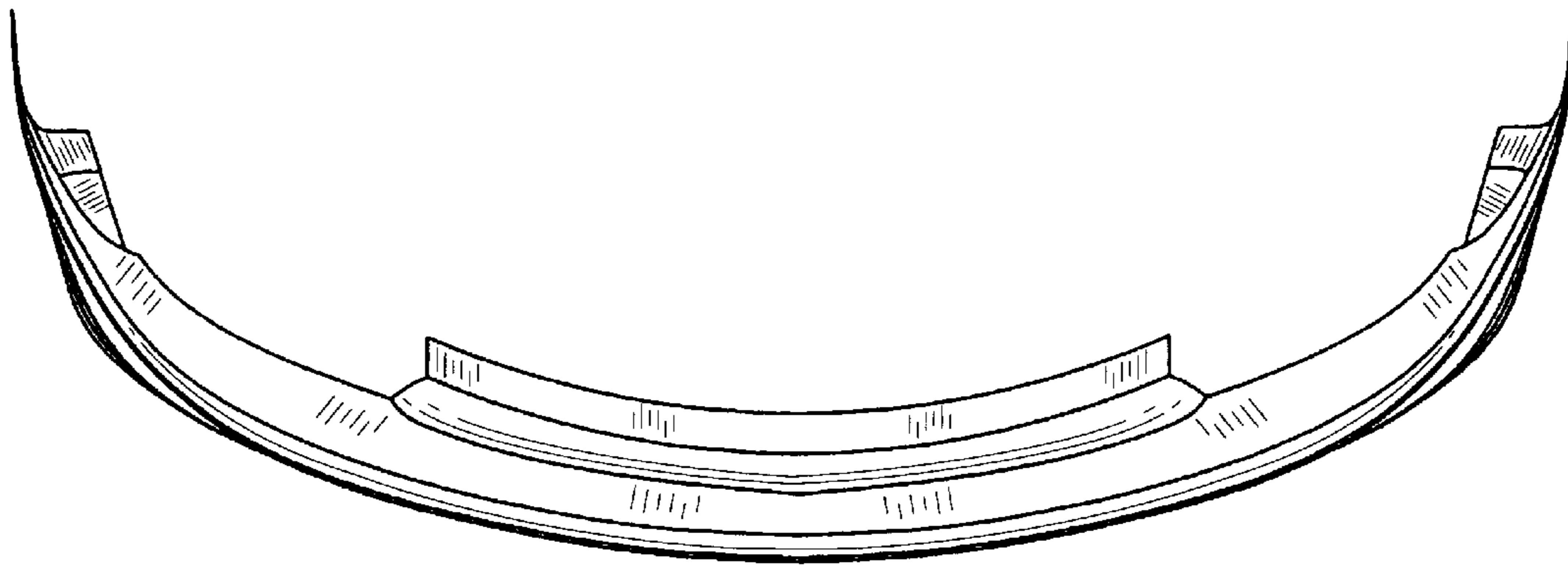

FIG. 4

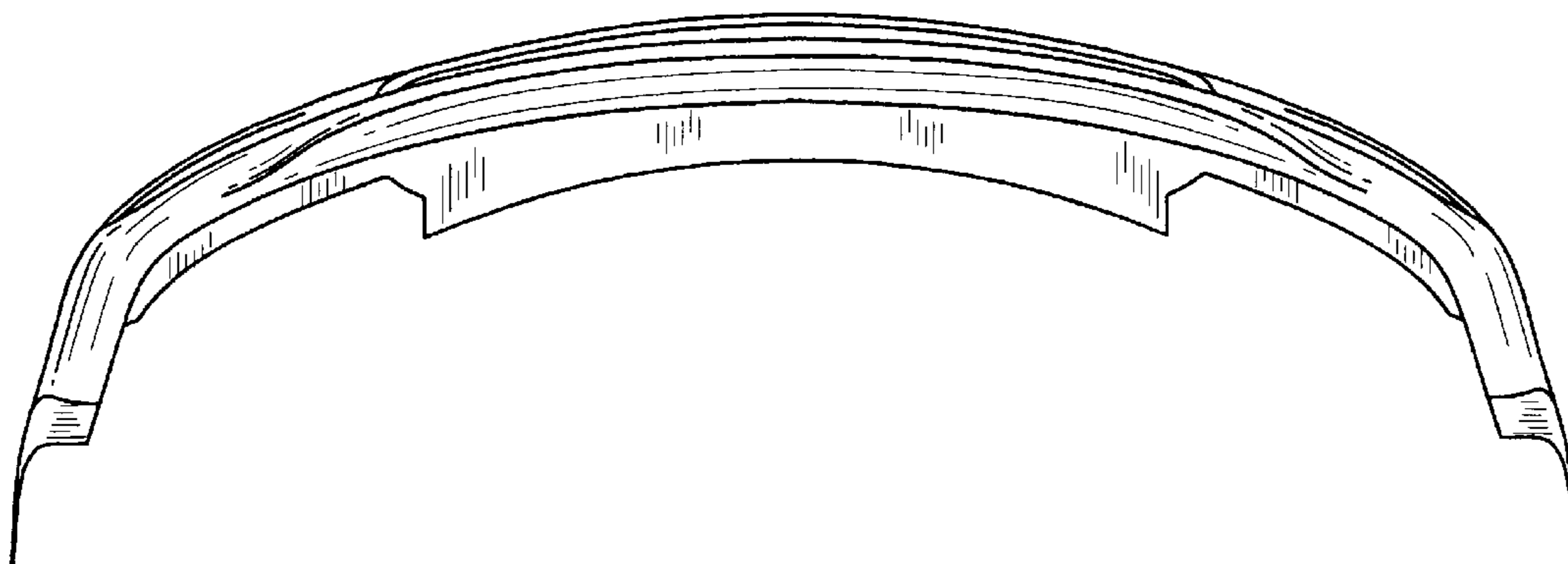

FIG. 5

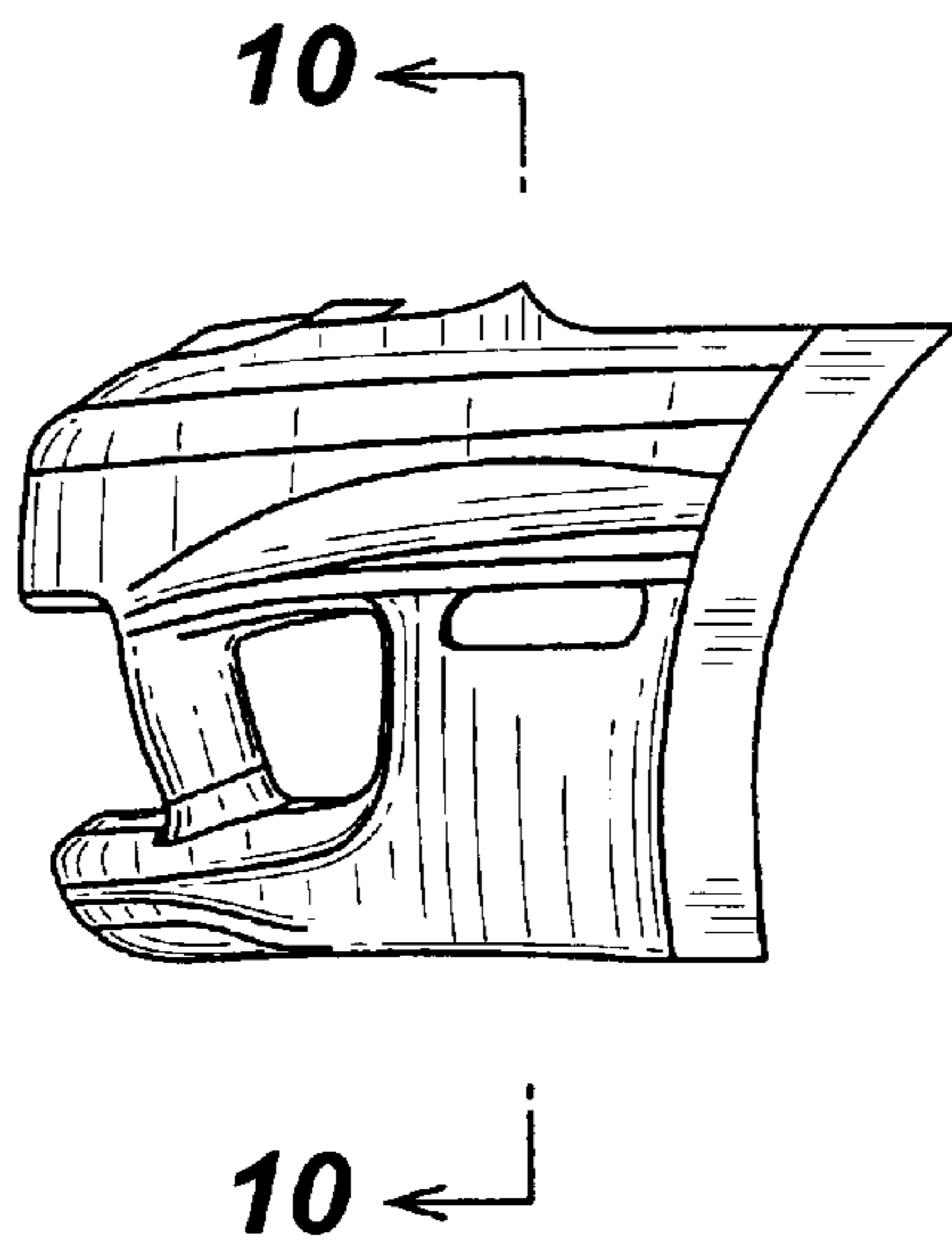

FIG. 6

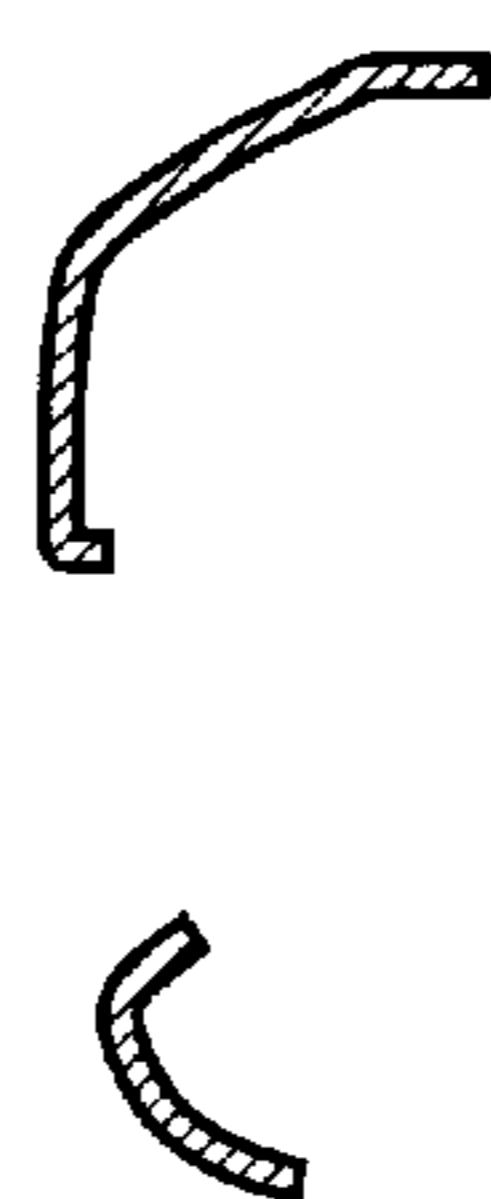

FIG. 7



FIG. 8



FIG. 9



FIG. 10