



US00D519895S

(12) **United States Design Patent**
Akimaru et al.

(10) **Patent No.:** **US D519,895 S**

(45) **Date of Patent:** **** May 2, 2006**

(54) **INSTRUMENT PANEL FOR AUTOMOBILE**

(75) Inventors: **Tatsuya Akimaru**, Wako (JP); **Hisashi Matsuura**, Wako (JP)

(73) Assignee: **Honda Motor Co., Ltd.**, Tokyo (JP)

(**) Term: **14 Years**

(21) Appl. No.: **29/239,031**

(22) Filed: **Sep. 26, 2005**

(30) **Foreign Application Priority Data**

Mar. 30, 2005 (JP) 2005-009492

(51) **LOC (8) Cl.** **12-16**

(52) **U.S. Cl.** **D12/192**

(58) **Field of Classification Search** D12/192;
180/90; 280/750-752; 296/190-191, 70;
D10/46, 102, 98, 122-127; D15/12, 28
See application file for complete search history.

(56) **References Cited**

U.S. PATENT DOCUMENTS

D179,266 S * 11/1956 Rich D12/192
D288,429 S * 2/1987 Cornwell D12/192
D291,985 S * 9/1987 Cornwell D12/192

D405,408 S * 2/1999 Yoshida et al. D12/192
D423,435 S * 4/2000 Sato D12/192
D470,807 S * 2/2003 Wyszogrod et al. D12/192
D488,417 S * 4/2004 Herrera, Jr. D12/192

* cited by examiner

Primary Examiner—Stacia Cadmus

(74) *Attorney, Agent, or Firm*—Sughrue Mion, PLLC

(57) **CLAIM**

The ornamental design for an instrument panel for automobile, as shown and described.

DESCRIPTION

FIG. 1 is a perspective view from the front left side of an instrument panel for automobile.

FIG. 2 is a perspective view from the front right side thereof.

FIG. 3 is a front elevation view thereof.

FIG. 4 is a rear elevation view thereof.

FIG. 5 is a top plan view thereof.

FIG. 6 is a left side elevation view thereof; and,

FIG. 7 is a right side elevation view thereof.

The portion of the article shown in broken lines is for illustrative purpose only and forms no part of the claimed design.

1 Claim, 7 Drawing Sheets

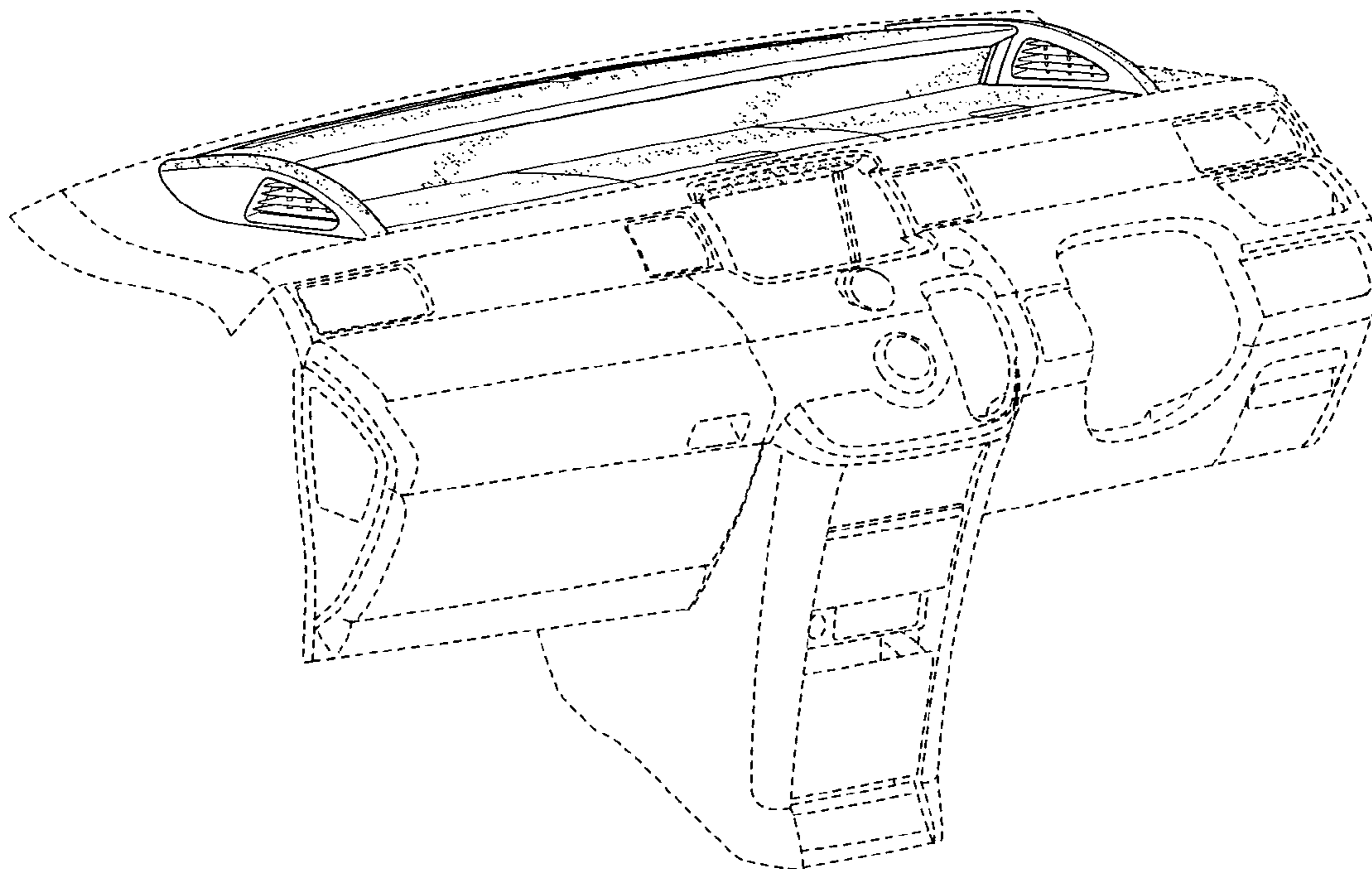

FIG. 1

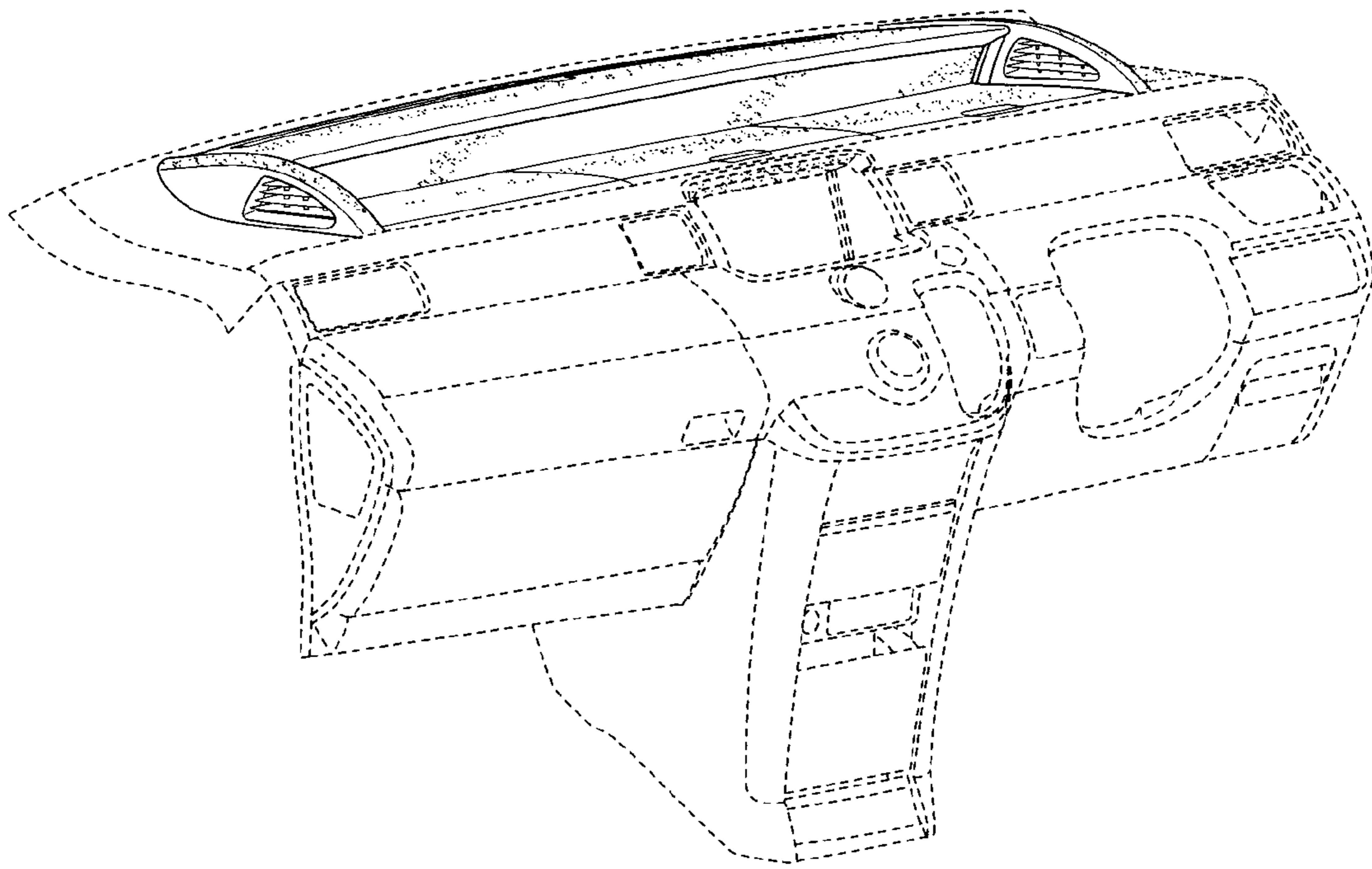

FIG. 2

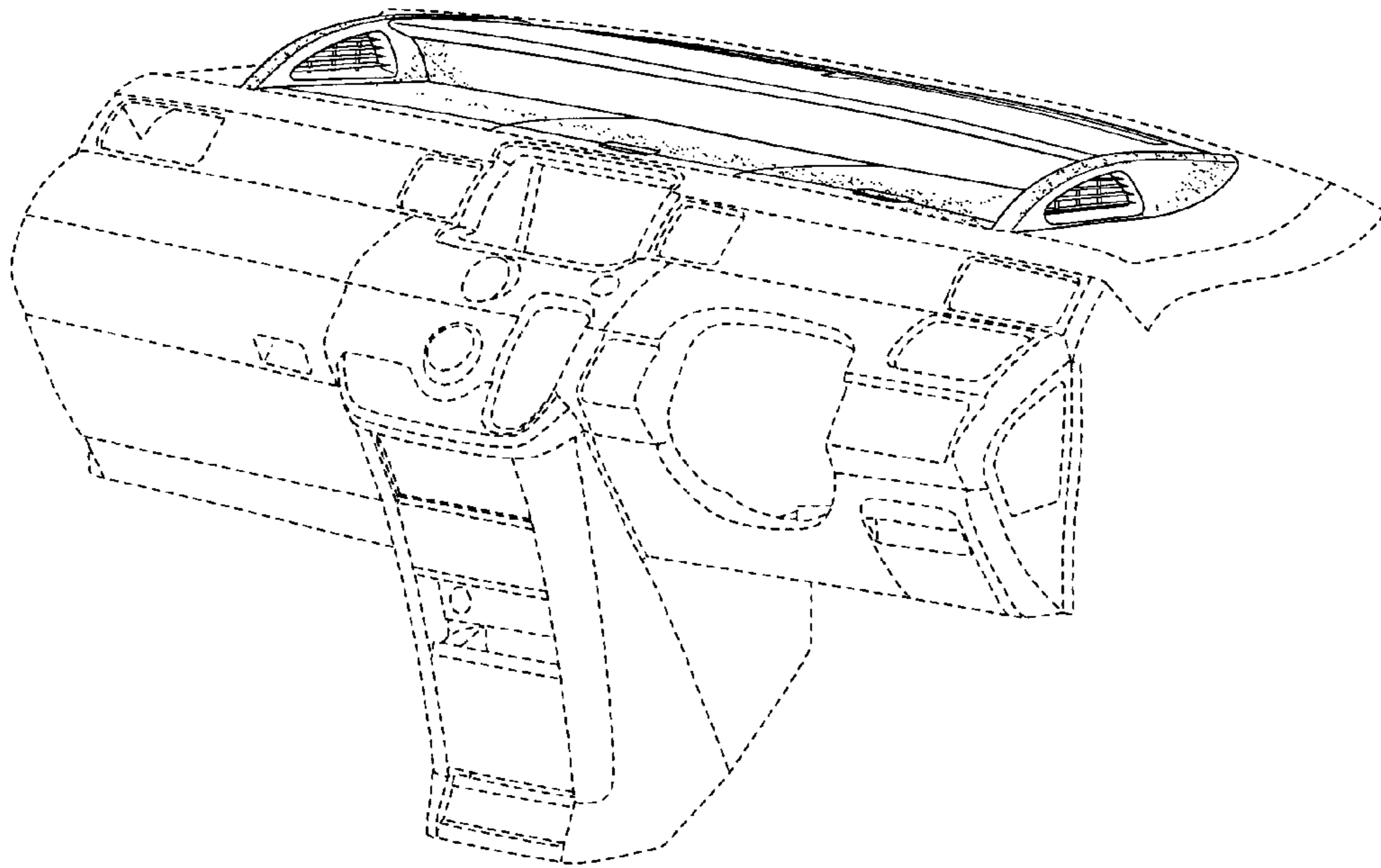

FIG. 3

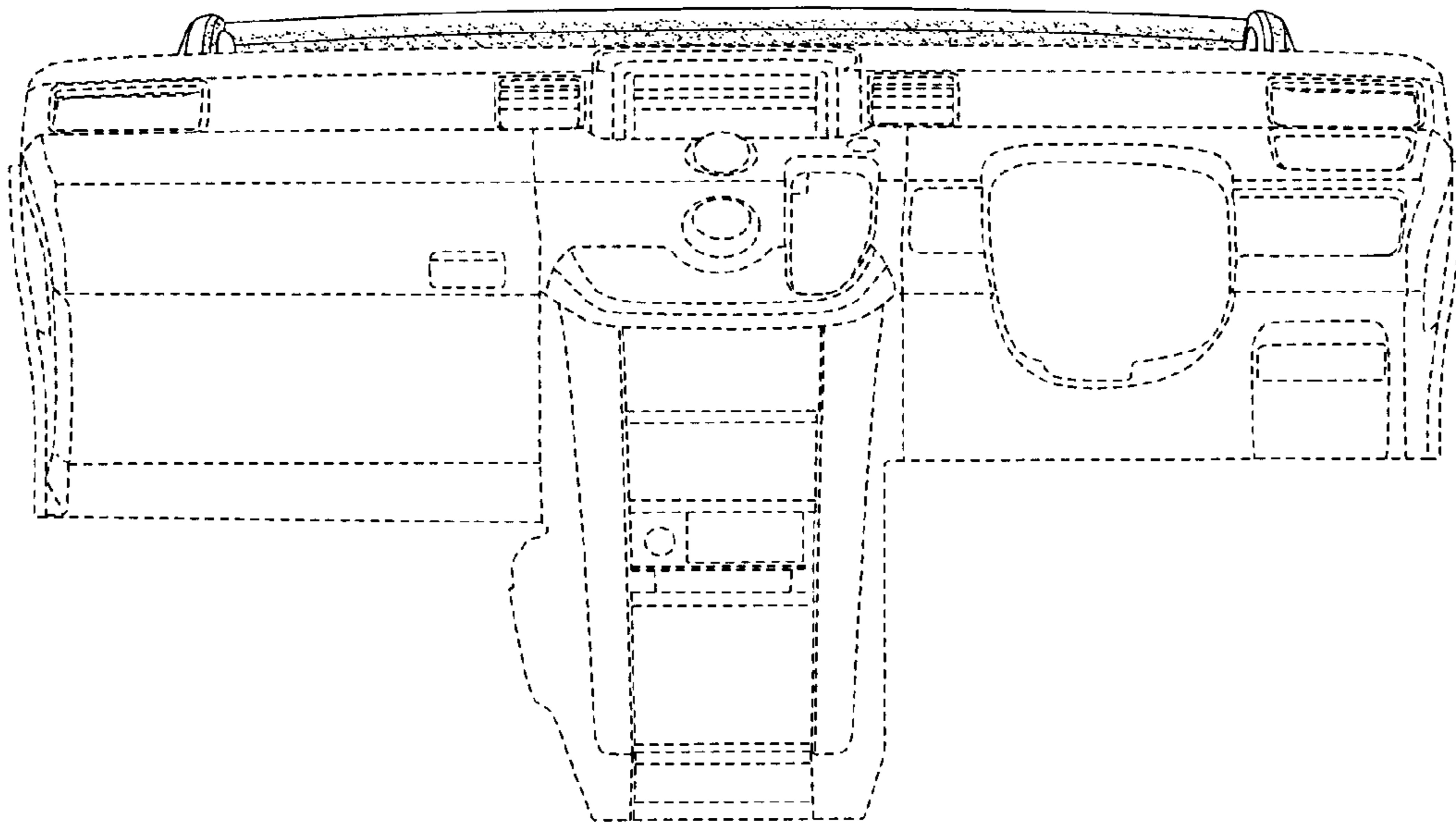

FIG. 4

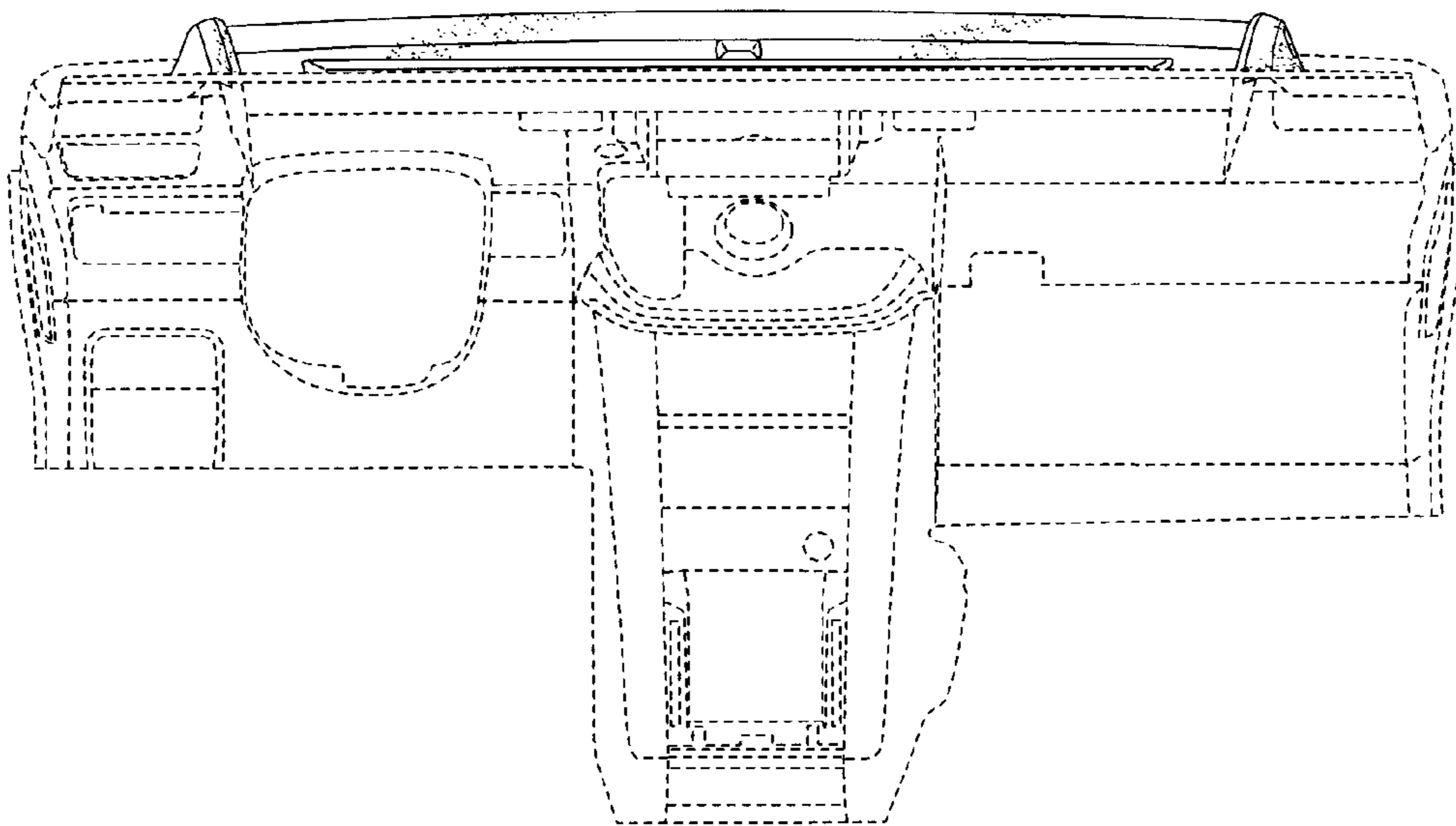

FIG. 5

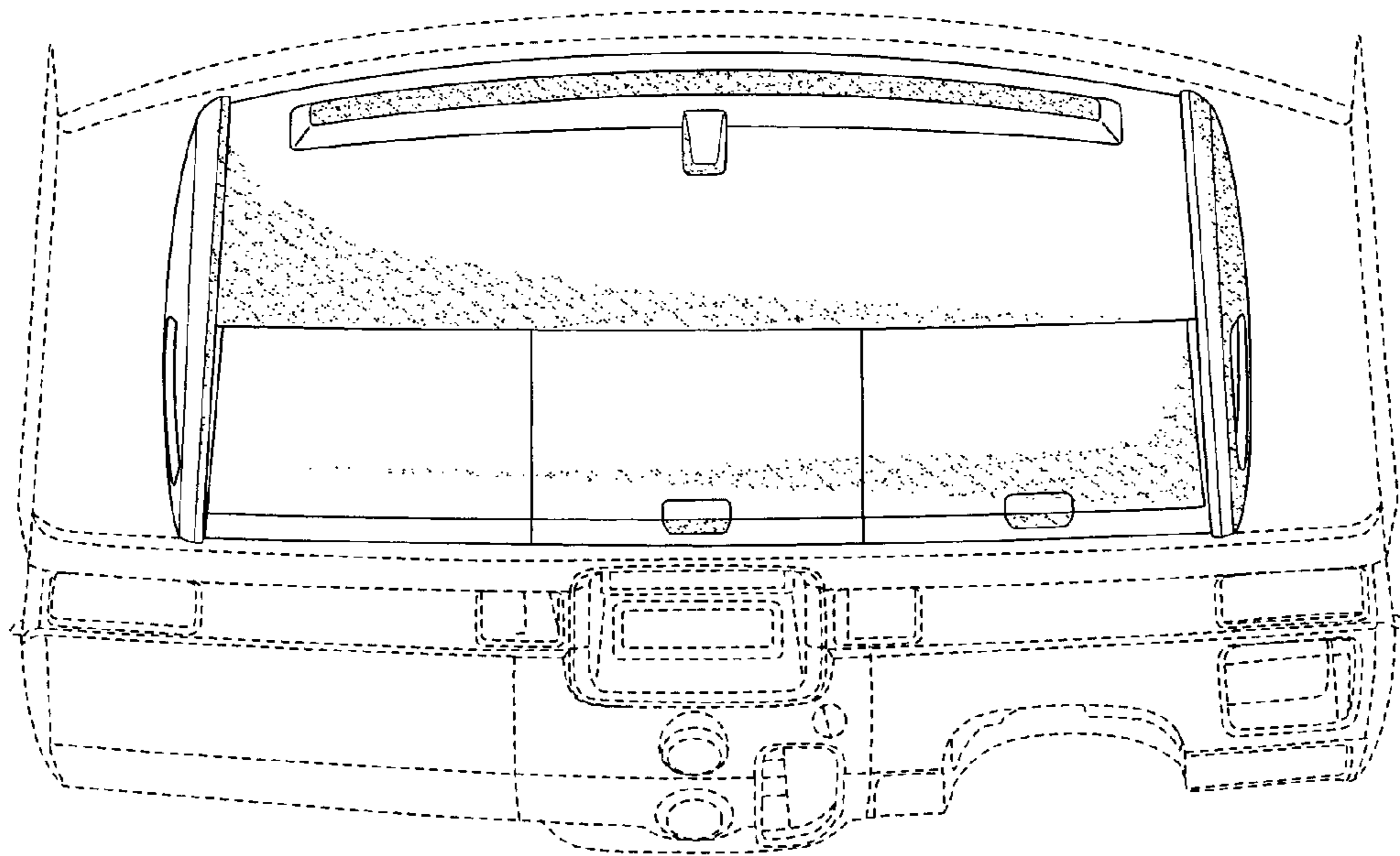

FIG. 6

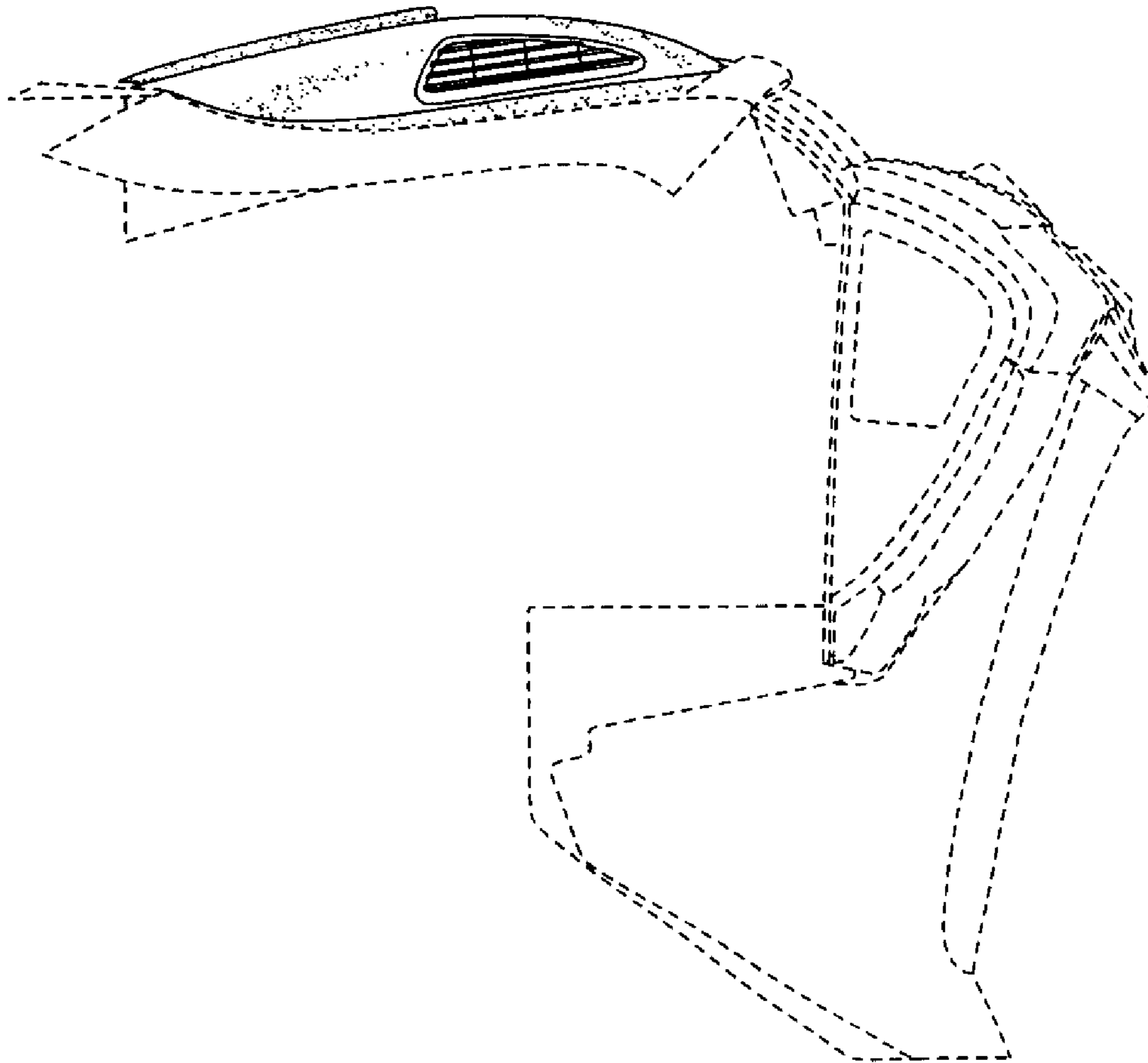

FIG. 7

