



US00D519826S

(12) **United States Design Patent**  
**Jackson et al.**

(10) **Patent No.:** **US D519,826 S**

(45) **Date of Patent:** **\*\* May 2, 2006**

(54) **TURN TO OPEN LATCH**

(75) Inventors: **Joe Jackson**, Wilmington, DE (US);  
**James H. Vickers**, Media, PA (US)

(73) Assignee: **Southco, Inc.**, Concordville, PA (US)

(\*\*) Term: **14 Years**

(21) Appl. No.: **29/215,678**

(22) Filed: **Oct. 22, 2004**

(51) **LOC (8) Cl.** ..... **08-07**

(52) **U.S. Cl.** ..... **D8/343**

(58) **Field of Classification Search** ..... D8/330,  
D8/331, 333, 343, 339, 302, 341; 70/77-79,  
70/57, 58, 89, 158, 230, 375, 423, 427, 455,  
70/372, 370.373, 381, 449, 379 R, DIG. 62,  
70/DIG. 43

See application file for complete search history.

(56) **References Cited**

**U.S. PATENT DOCUMENTS**

3,053,110	A	*	9/1962	Shalek	.....	74/504
3,539,738	A	*	11/1970	Bowen et al.	.....	200/47
3,550,472	A		12/1970	Dummer		
3,686,601	A		8/1972	Kaczmarek et al.	.....	337/66
3,741,619	A	*	6/1973	Dyer et al.	.....	312/215
4,000,382	A		12/1976	Kolb	.....	200/4
4,406,933	A		9/1983	Boozer	.....	200/47
4,715,201	A	*	12/1987	Craig	.....	70/369
D312,769	S	*	12/1990	Bisbing	.....	D8/338

5,251,467	A	*	10/1993	Anderson	.....	70/370
D361,984	S		9/1995	Levine	.....	D13/174
D362,842	S		10/1995	Levine	.....	D13/174
5,634,359	A	*	6/1997	Huebschen	.....	70/379 R
D433,309	S	*	11/2000	Johansson et al.	.....	D8/331
D471,428	S	*	3/2003	Mirick	.....	D8/331

**OTHER PUBLICATIONS**

Sierra Marine Catalog, p. 39, as early as 2004; Sierra Marine  
1a Division of Teleflex Marine.

Southco Handbook 2003, pp. 123-125, Southco, Inc.

\* cited by examiner

*Primary Examiner*—Prabhakar Deshmukh

(74) *Attorney, Agent, or Firm*—Paul & Paul

(57) **CLAIM**

The ornamental design for a turn to open latch, as shown and  
described.

**DESCRIPTION**

FIG. 1 is a perspective view of a turn to open latch showing  
our new design;

FIG. 2 is a left side elevational view thereof;

FIG. 3 is a right side elevational view thereof;

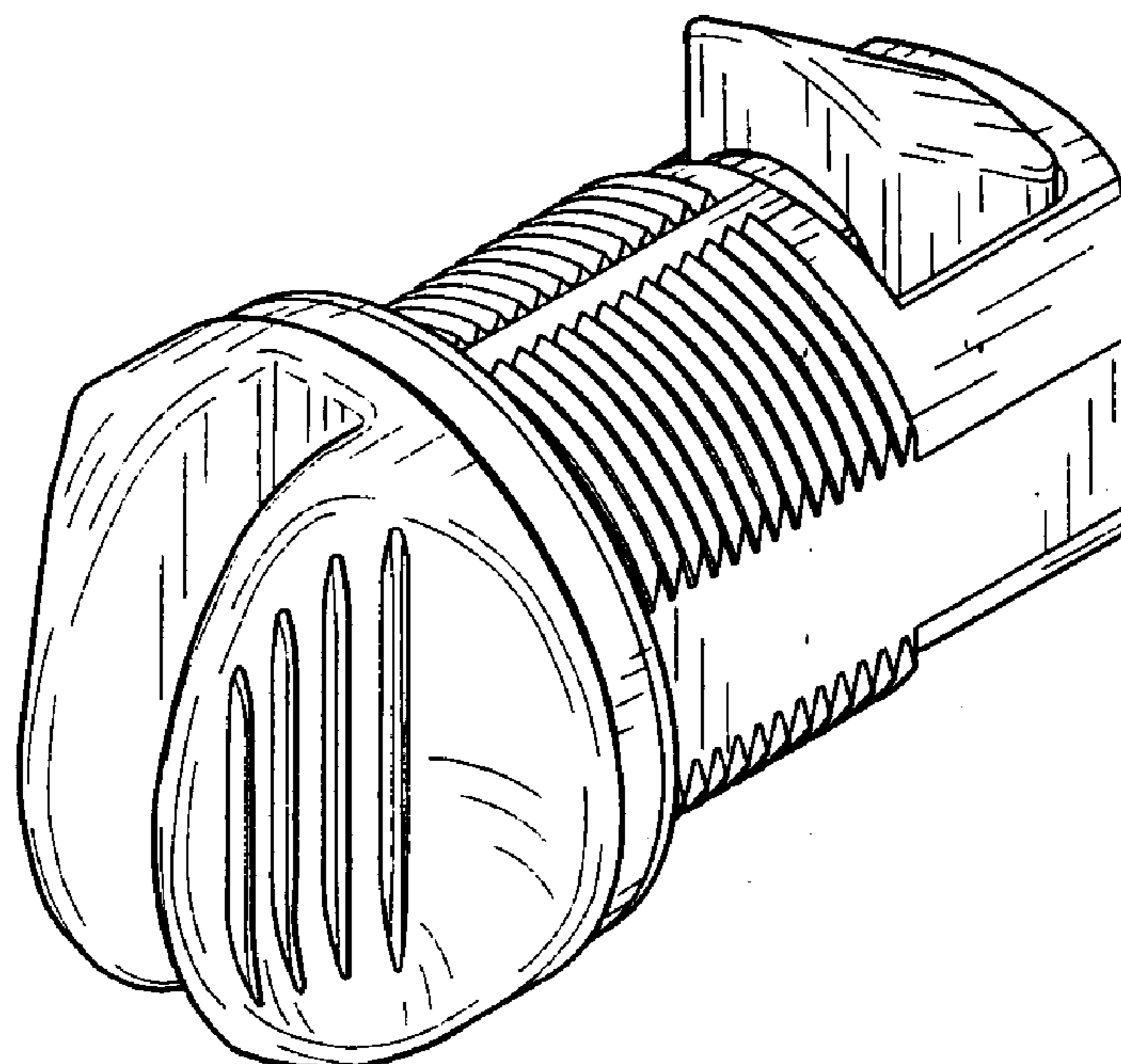
FIG. 4 is a top plan view thereof;

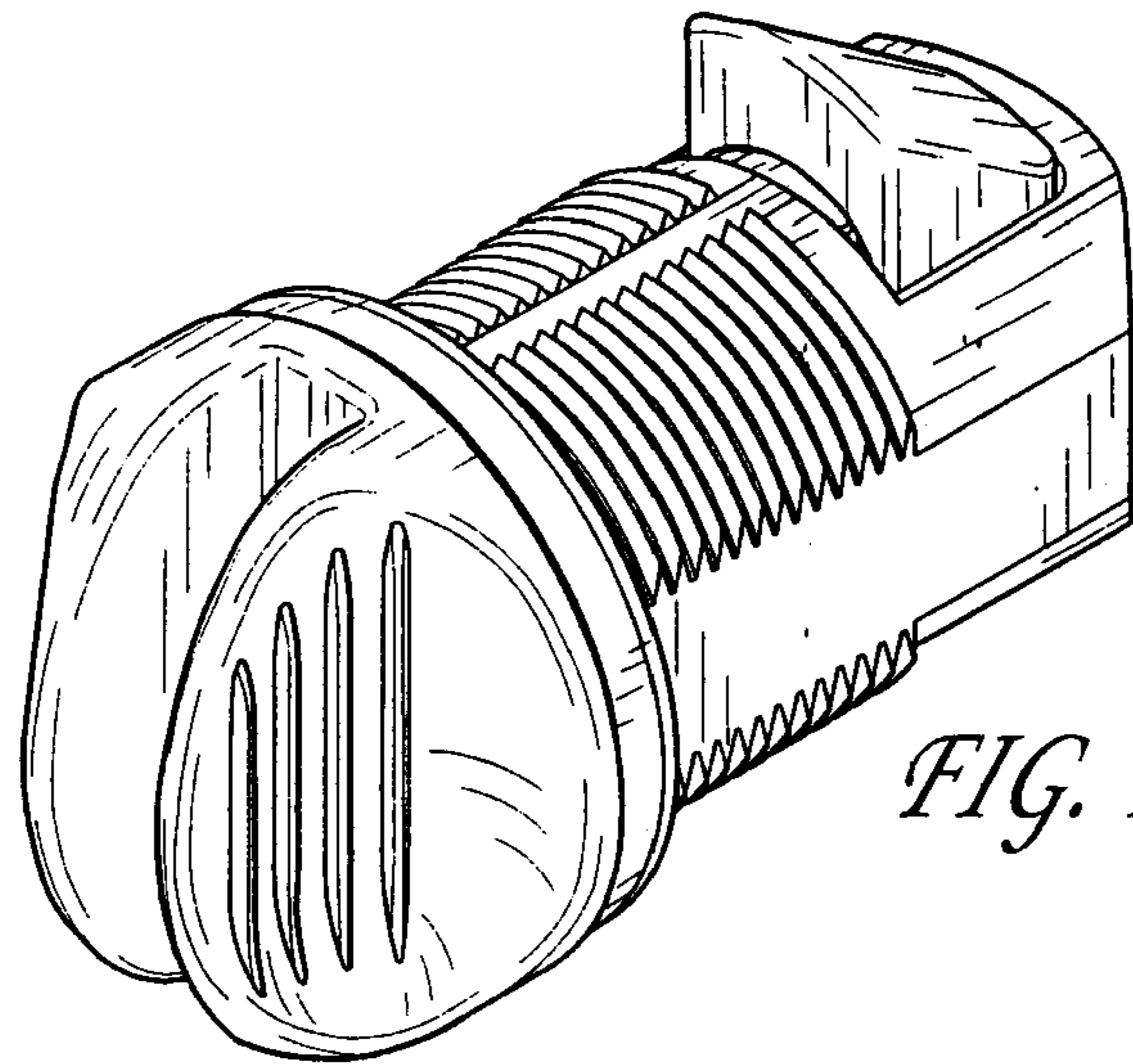
FIG. 5 is a front view thereof;

FIG. 6 is a rear view thereof; and,

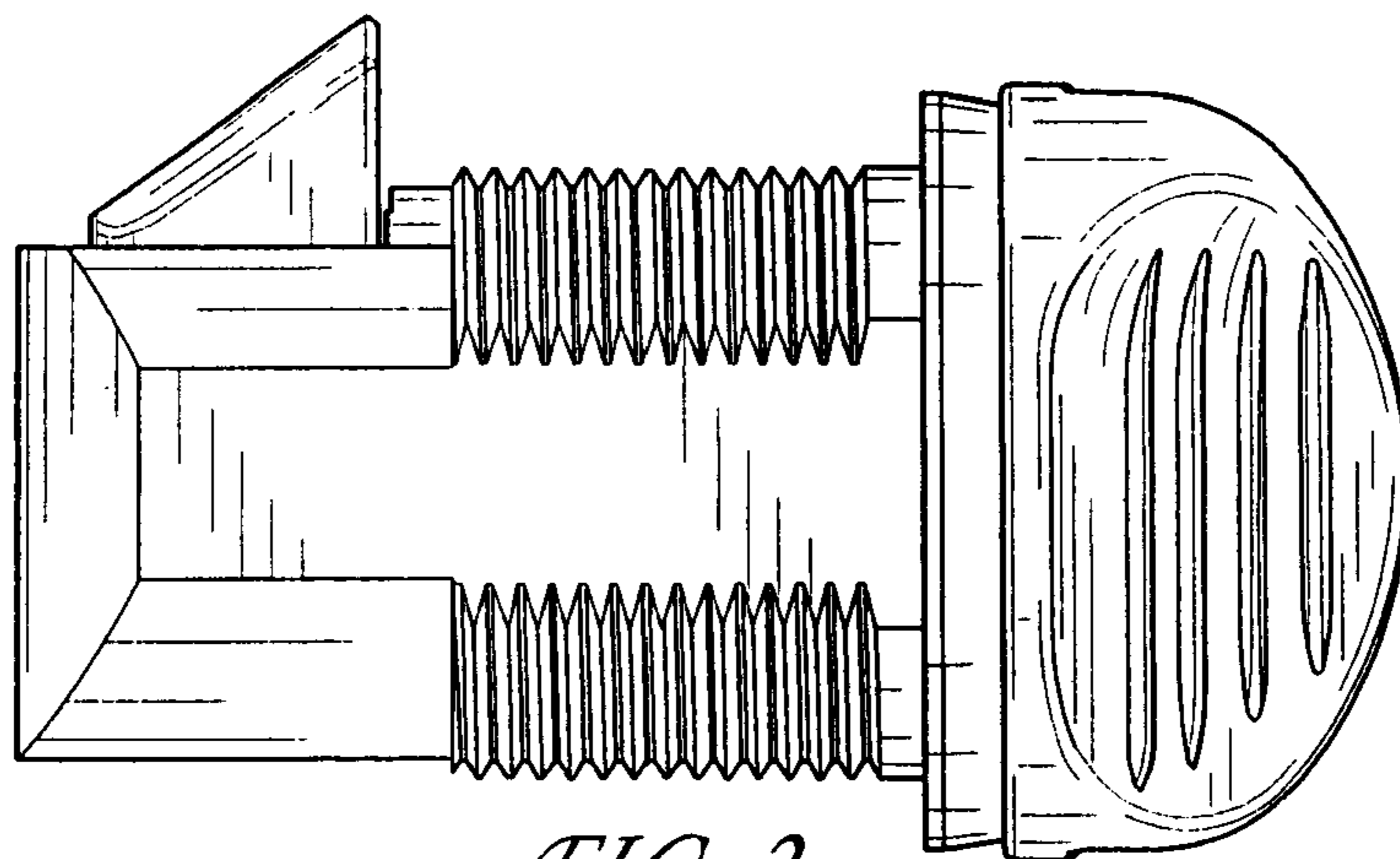
FIG. 7 is a bottom plan view thereof.

**1 Claim, 2 Drawing Sheets**

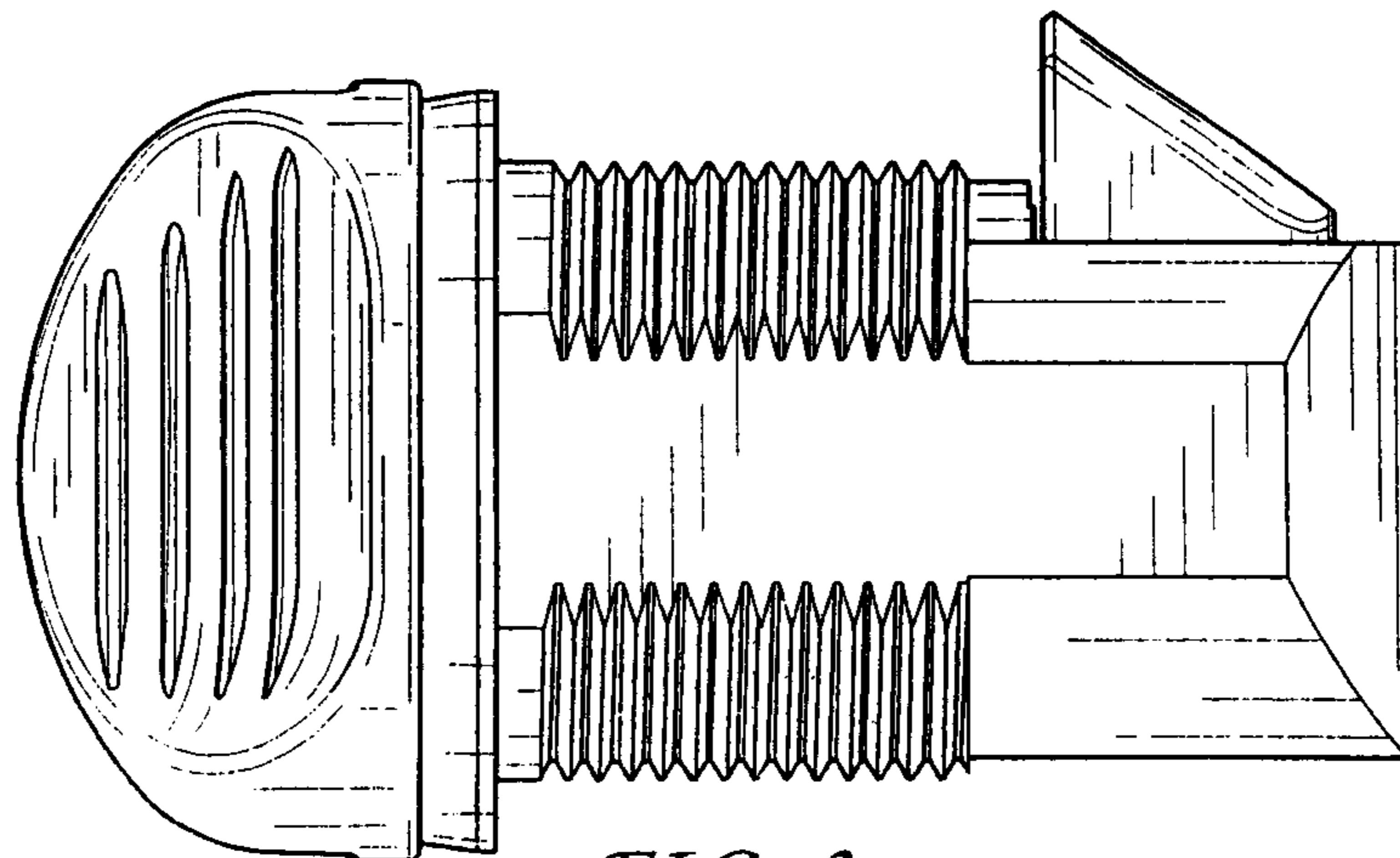




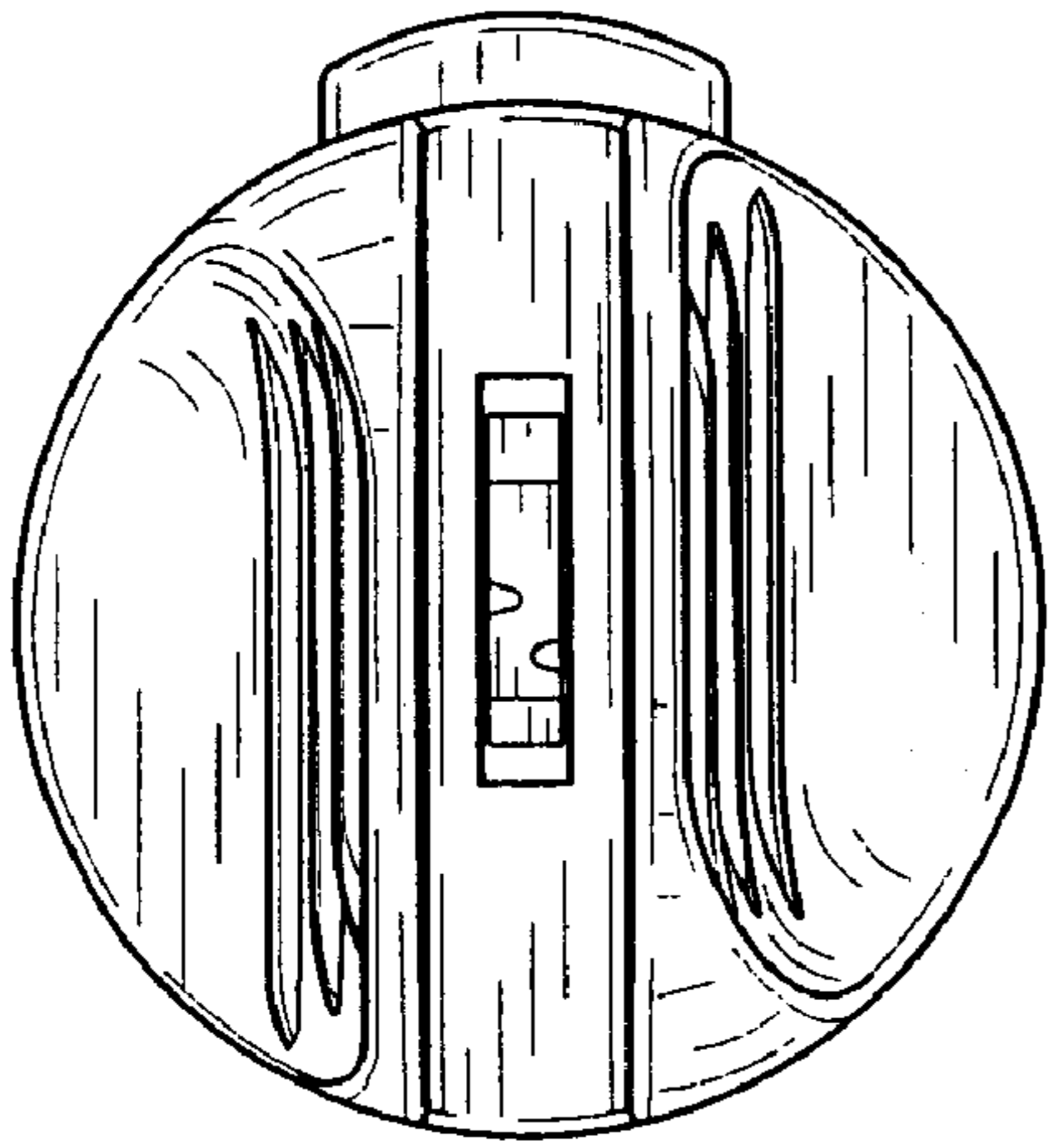
*FIG. 1*



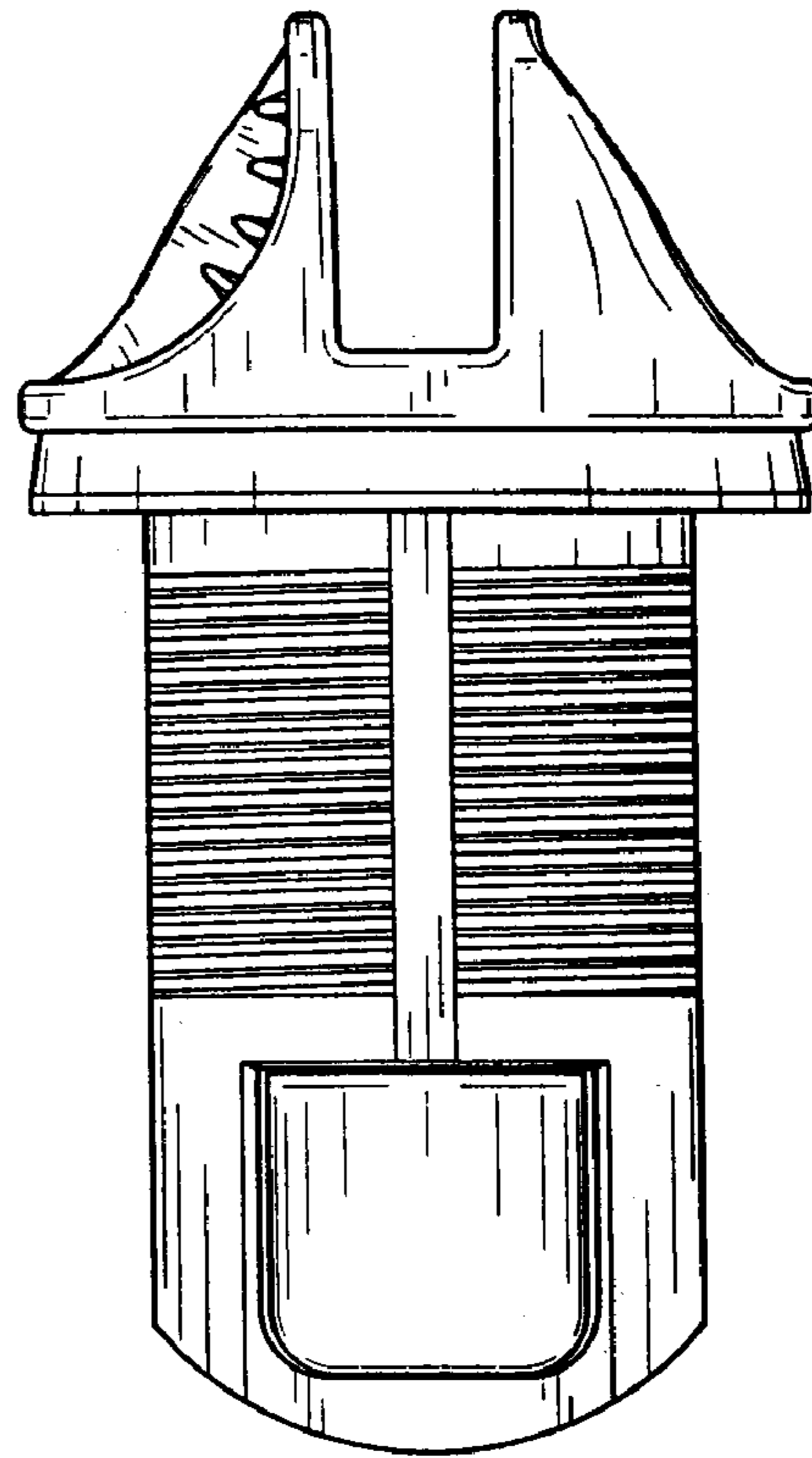
*FIG. 2*



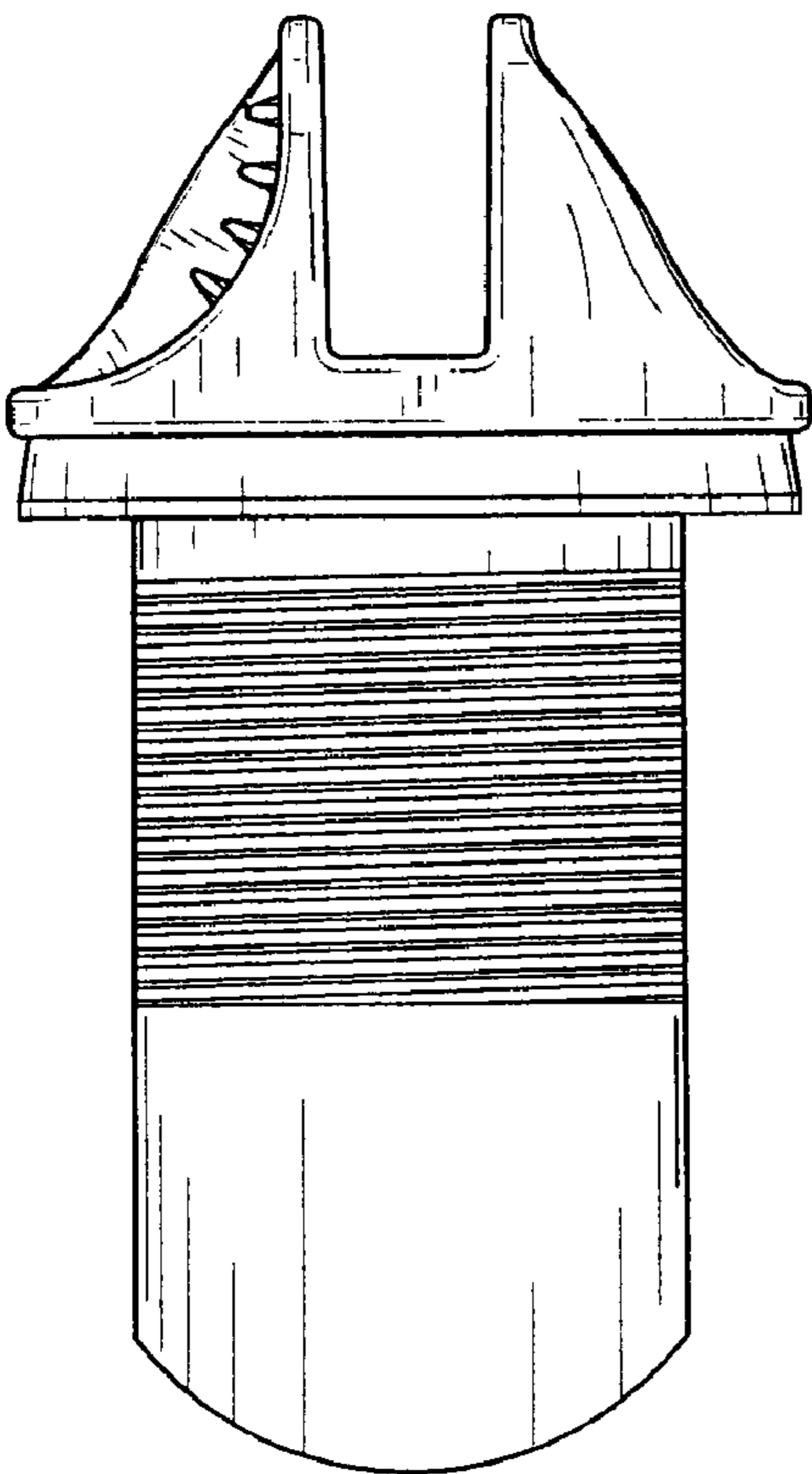
*FIG. 3*



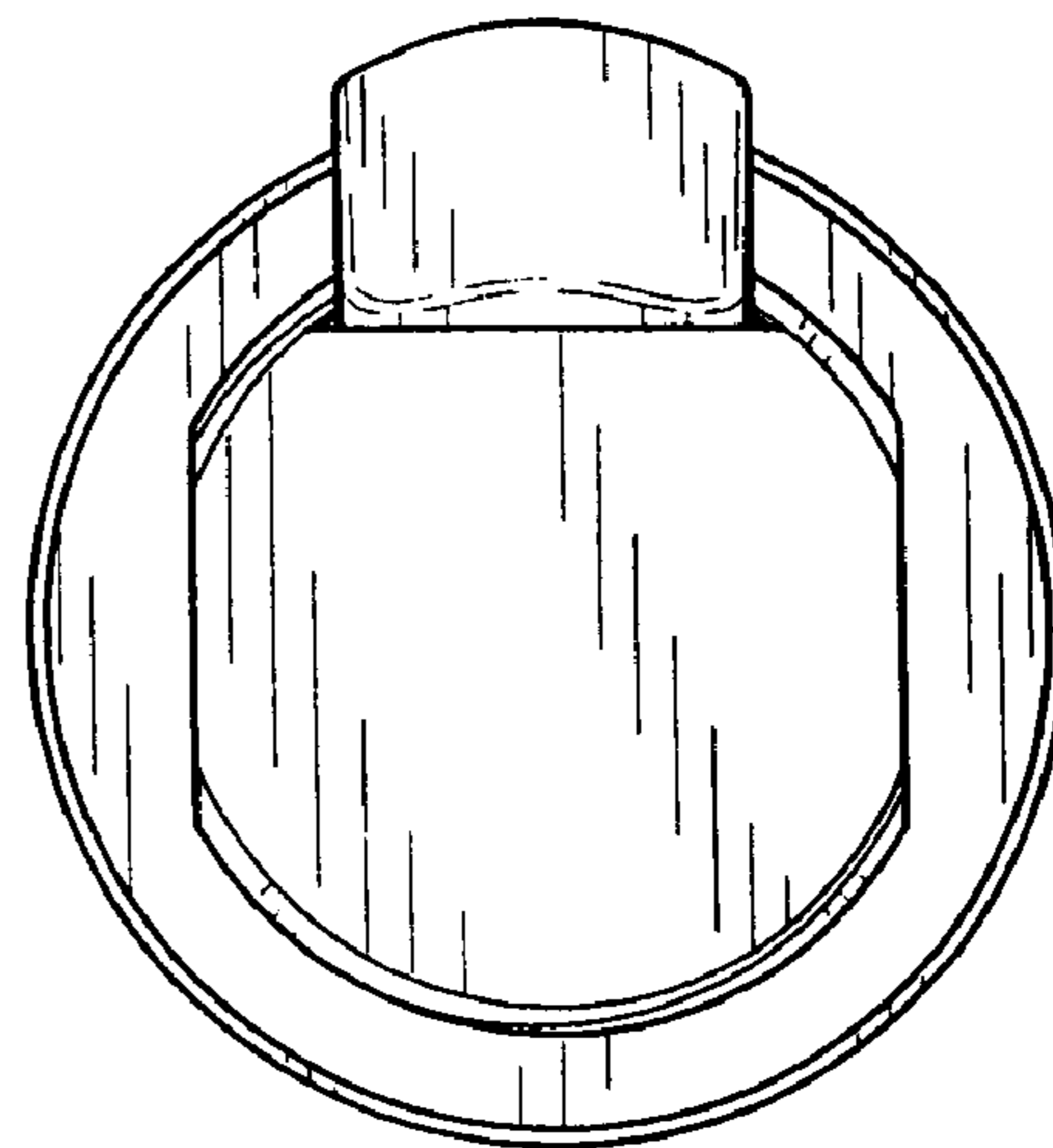
*FIG. 4*



*FIG. 5*



*FIG. 6*



*FIG. 7*