



US00D519427S

(12) **United States Design Patent**
Haddock

(10) **Patent No.:** **US D519,427 S**

(45) **Date of Patent:** **** Apr. 25, 2006**

(54) **MOTORCYCLE FENDER SKIRT**

(75) Inventor: **Dwight N. Haddock**, Combine, TX
(US)

(73) Assignee: **DNH Management LLC**, Combine,
TX (US)

(**) Term: **14 Years**

(21) Appl. No.: **29/220,508**

(22) Filed: **Dec. 30, 2004**

(51) **LOC (8) Cl.** **12-16**

(52) **U.S. Cl.** **D12/186; D12/410**

(58) **Field of Classification Search** D12/110,
D12/114, 126, 181, 184-186, 410; 280/847-852,
280/160.1, 152.1-152.3, 770; 296/78.1, 95.1,
296/198; 180/219; 293/105

See application file for complete search history.

(56) **References Cited**

U.S. PATENT DOCUMENTS

2,757,018 A	7/1956	Galla	
3,788,532 A	1/1974	Bish	
4,441,574 A	4/1984	Kohyama et al.	
4,479,676 A	10/1984	Hayes	
D321,160 S	10/1991	Kingsley	
D345,332 S	3/1994	Roman	
D345,333 S	3/1994	Roman	
D346,577 S	5/1994	Roman	
D405,038 S	2/1999	LeBlanc	
5,881,835 A	3/1999	Lucht et al.	
5,957,233 A *	9/1999	Hylla	180/219
D440,920 S	4/2001	Nelson et al.	
D442,893 S	5/2001	Golden et al.	

D447,990 S	9/2001	Yokomaku
D476,927 S	7/2003	Delgado
D477,257 S	7/2003	Delgado
6,585,072 B1	7/2003	Scherbarth
D489,030 S	4/2004	Pittam et al.

* cited by examiner

Primary Examiner—Alan P. Douglas

Assistant Examiner—Linda Brooks

(57) **CLAIM**

The ornamental design for a motorcycle fender skirt, as shown and described.

DESCRIPTION

FIG. 1 is a side perspective view of a motorcycle fender skirt shown in position of use from the right side of a motorcycle; FIG. 2 is a rear perspective view thereof, shown in position of use from the right rear side of a motorcycle; FIG. 3 is an enlarged perspective view thereof; FIG. 4 is an enlarged top plan view thereof; FIG. 5 is an enlarged right side elevational view thereof; FIG. 6 is an enlarged rear elevational view thereof; and, FIG. 7 is an enlarged front elevational view thereof.

The broken line showing of the environment is for illustrative purposes only and forms no part of the claimed design. The interior side and bottom portions of the motorcycle fender skirt that are not shown form no part of the claimed design. The second embodiment of my new design is a motorcycle fender skirt which is attached to the left side of a motorcycle, which is a mirror image of the motorcycle fender skirt shown in FIGS. 1-7 and is not shown for convenience of illustration.

1 Claim, 3 Drawing Sheets

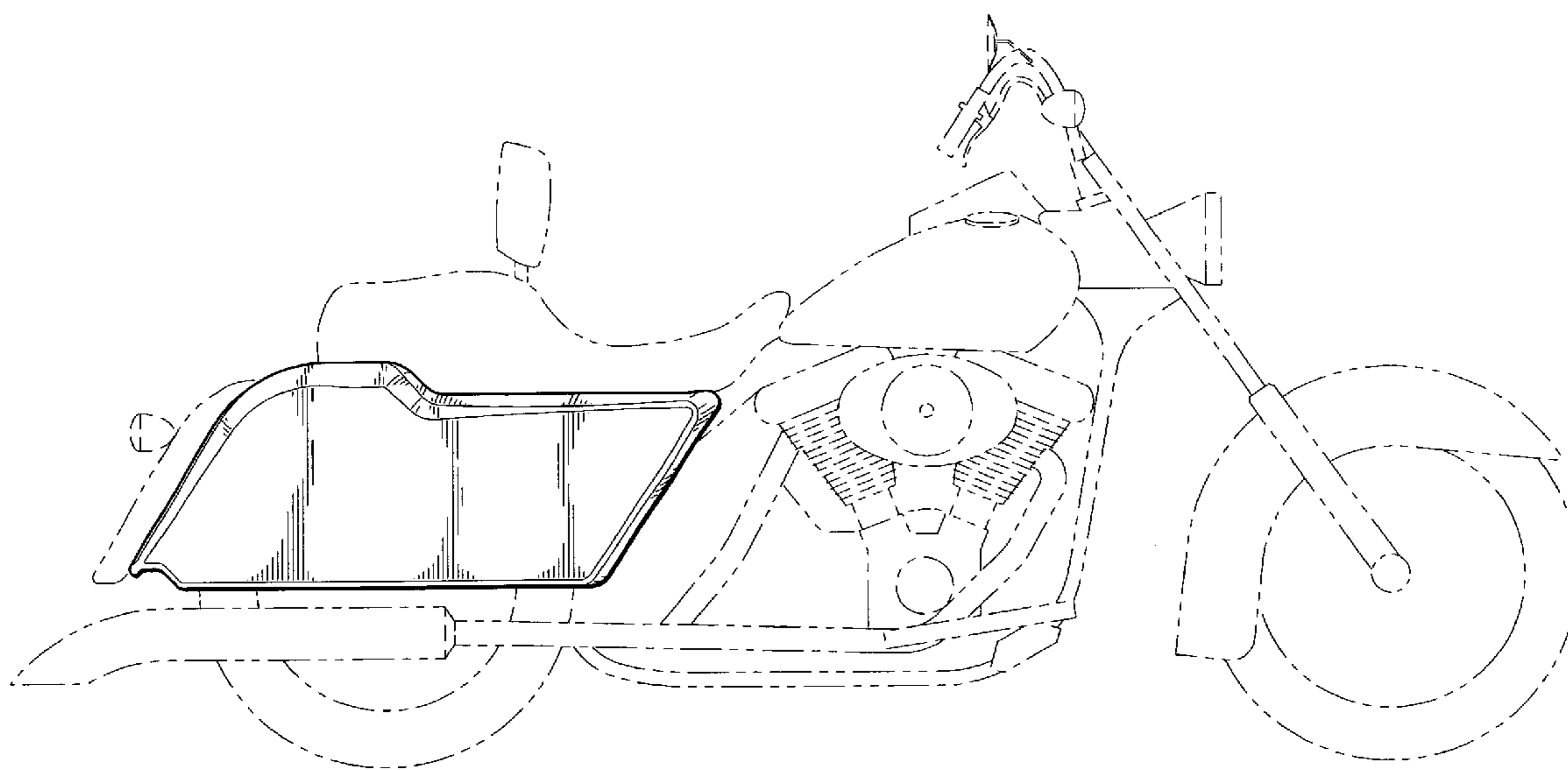

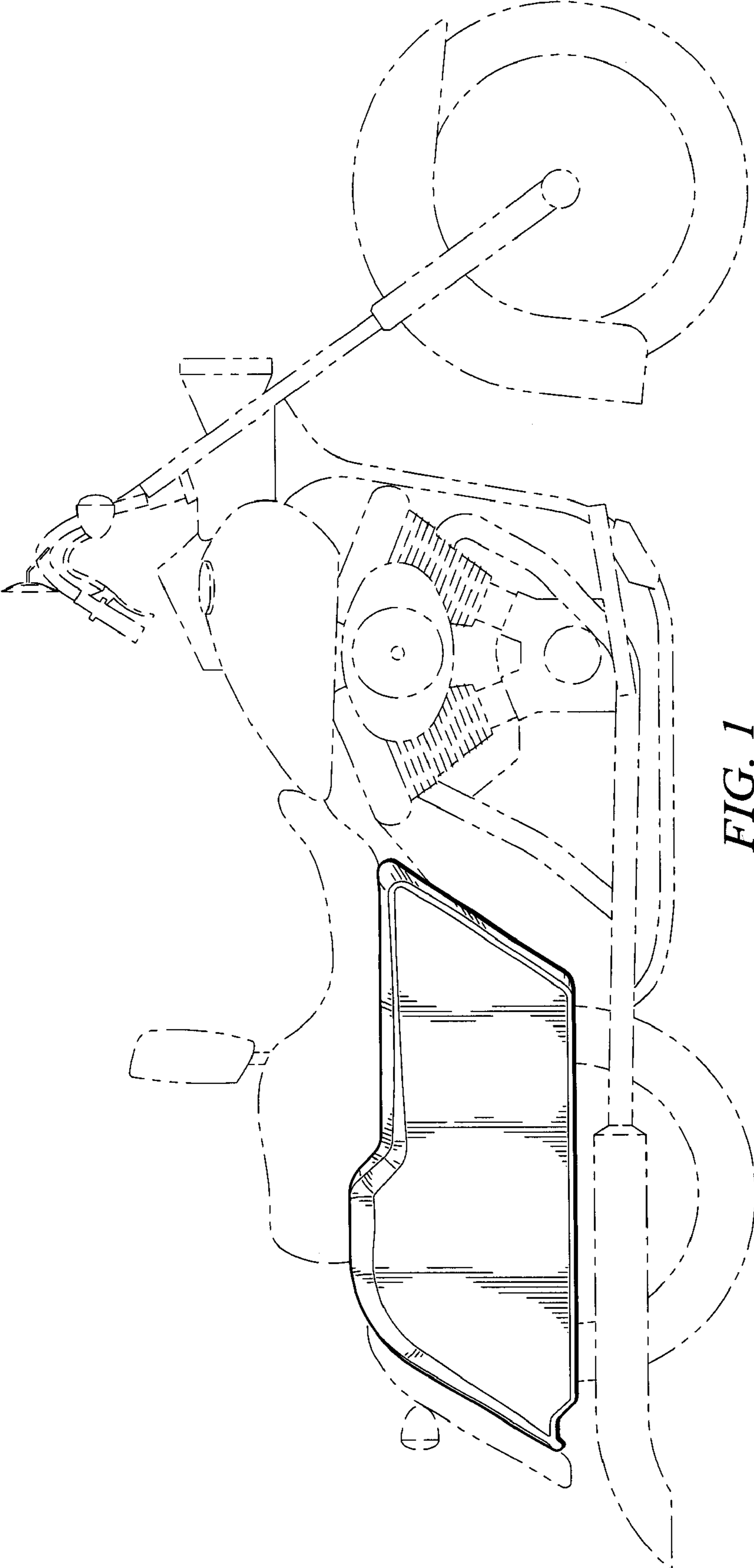

FIG. 1

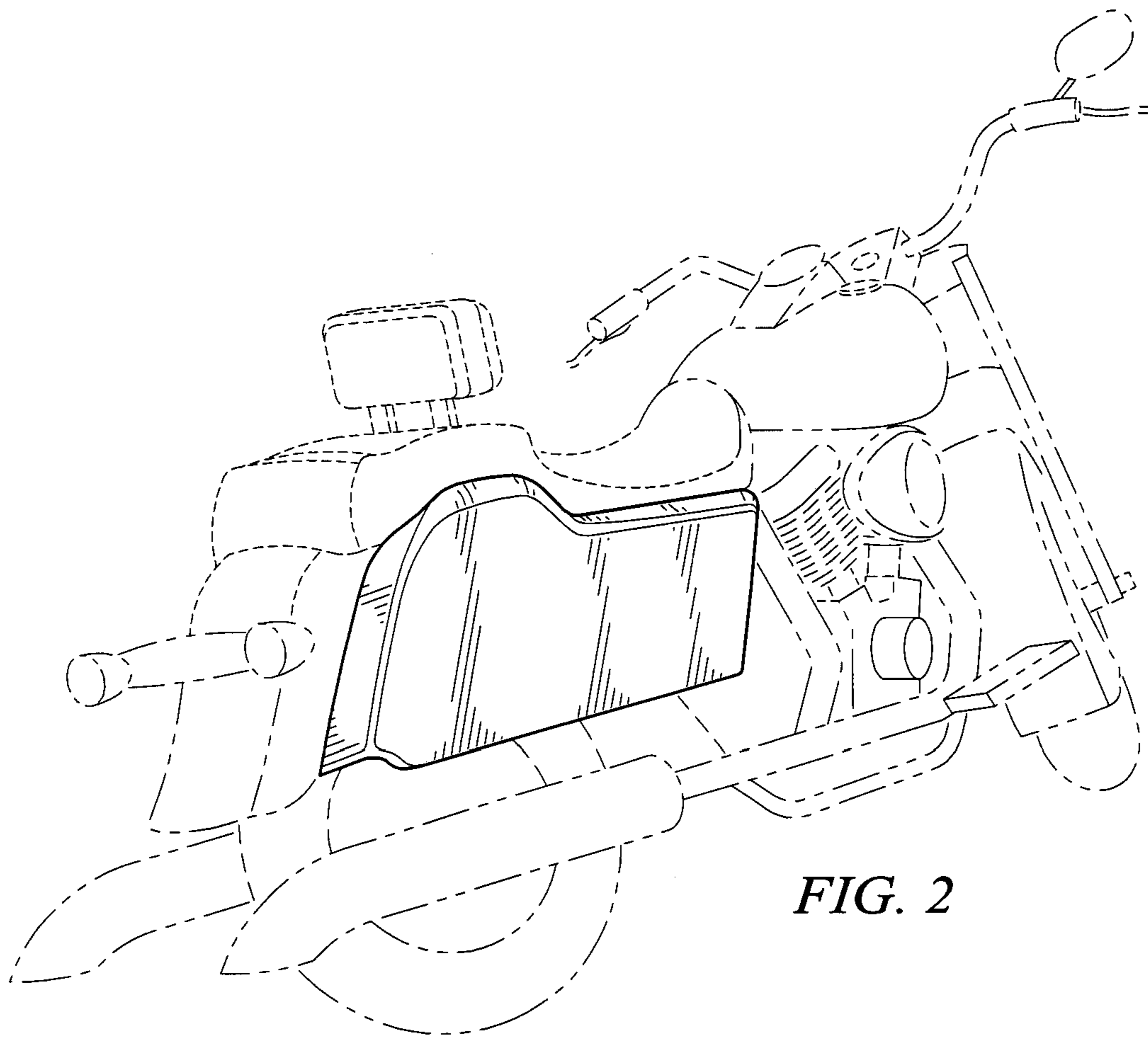

FIG. 2

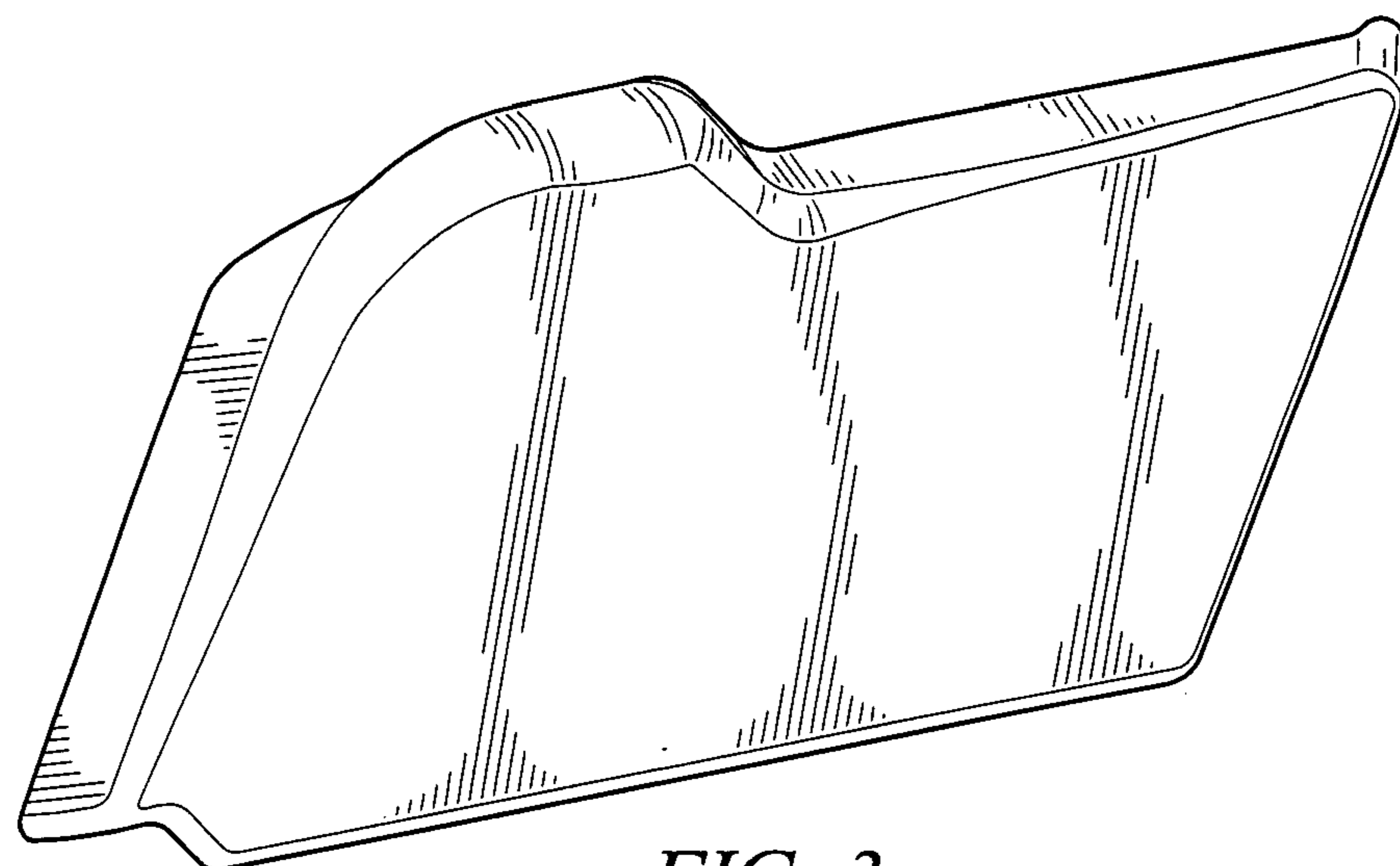

FIG. 3

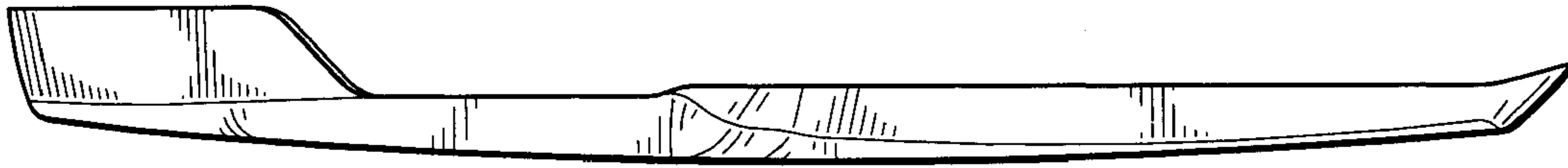

FIG. 4

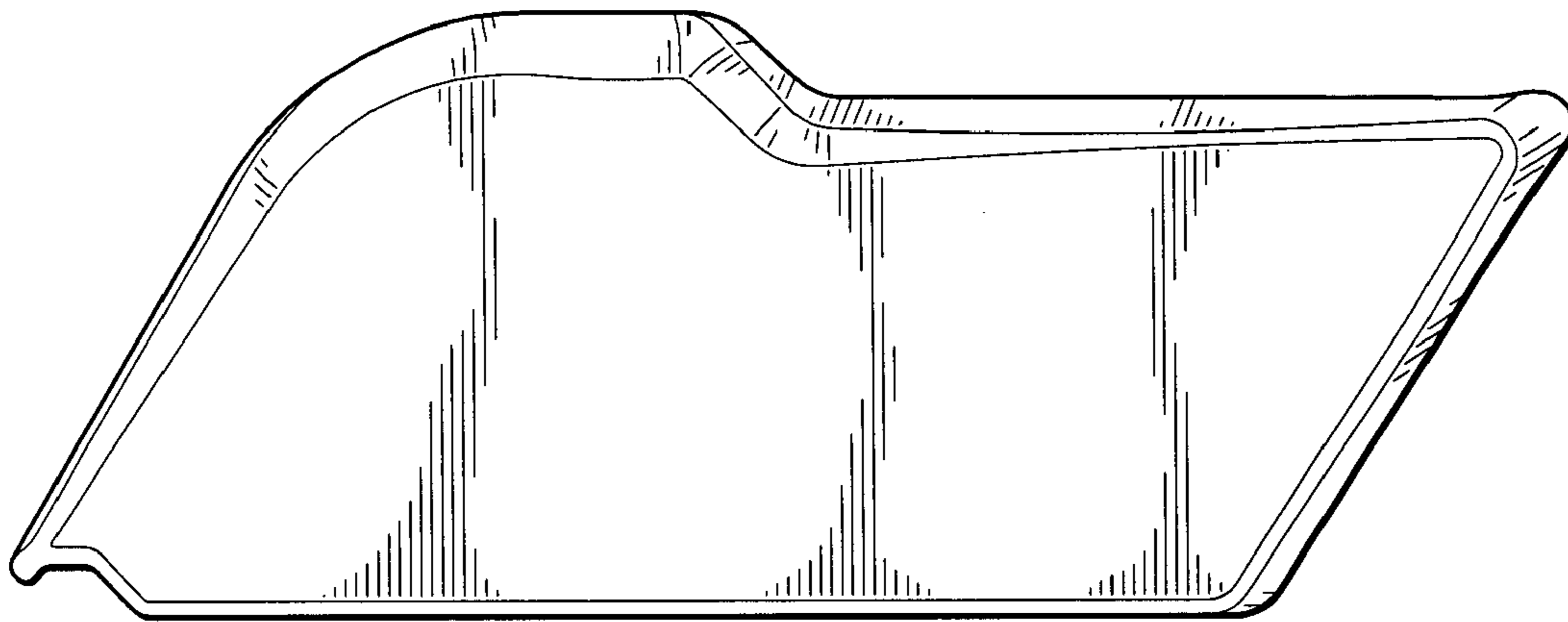

FIG. 5

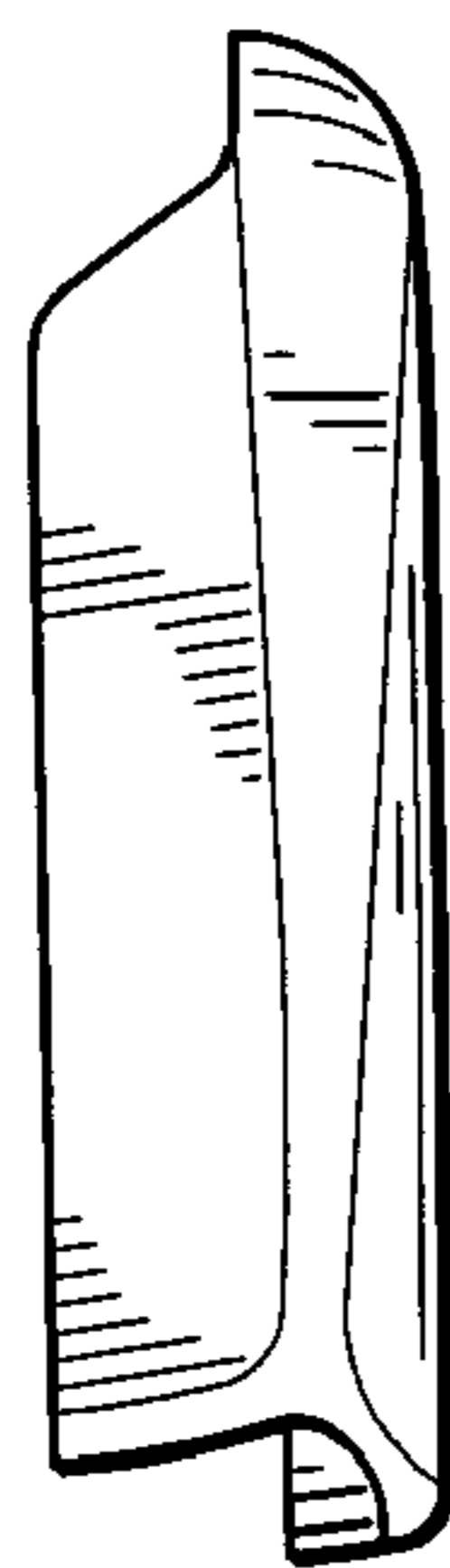

FIG. 6

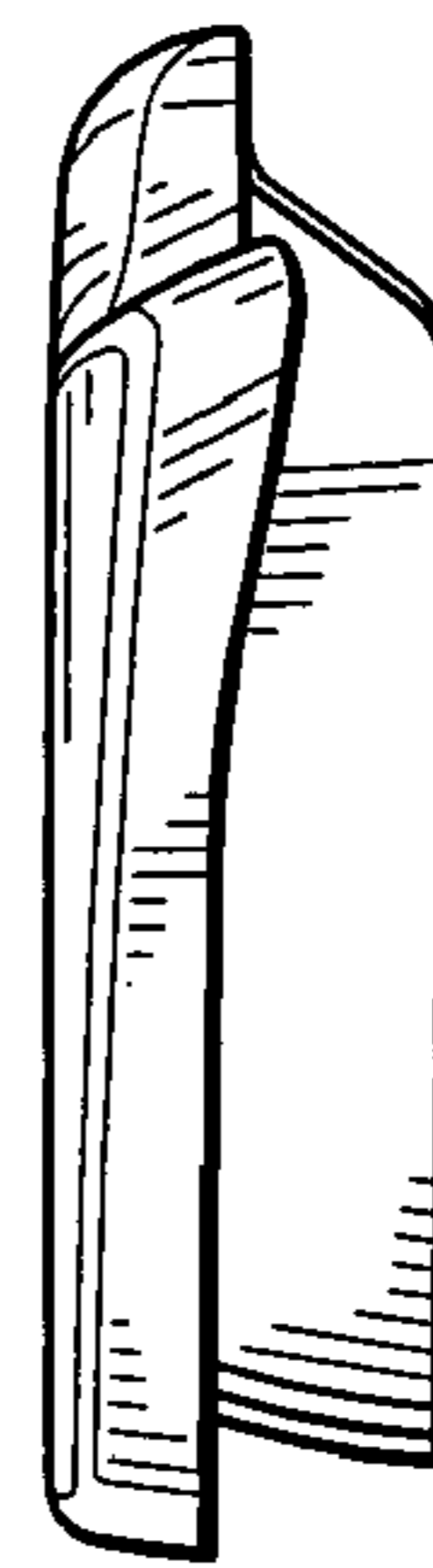

FIG. 7