



US00D519123S

(12) **United States Design Patent**  
**Elliott**

(10) **Patent No.:** **US D519,123 S**

(45) **Date of Patent:** **\*\* Apr. 18, 2006**

(54) **THROTTLE CONTROL LEVER**

(76) Inventor: **Clifton P. Elliott**, 15 Arrowhead Rd.,  
Topsfield, MA (US) 01983

(\*\*) Term: **14 Years**

(21) Appl. No.: **29/190,367**

(22) Filed: **Sep. 18, 2003**

(51) **LOC (8) Cl.** ..... **15-05**

(52) **U.S. Cl.** ..... **D15/5**

(58) **Field of Classification Search** ..... D15/1-5;  
74/480 R, 489; D12/179; 123/400; 200/61.86  
See application file for complete search history.

(56) **References Cited**

**U.S. PATENT DOCUMENTS**

4,619,341	A	10/1986	Davis	180/335
4,798,185	A	* 1/1989	Driggers	123/400
4,899,610	A	2/1990	Bourret	74/489
D313,785	S	* 1/1991	Bourret	D12/179
5,078,023	A	1/1992	Scarborough	74/502
5,775,167	A	7/1998	Maietta	74/480
6,167,776	B1	1/2001	Cossette	74/480
6,170,590	B1	1/2001	Hisadomi	180/190
6,393,933	B1	5/2002	Shirayanagi	74/489

\* cited by examiner

*Primary Examiner*—Caron D. Veynar

*Assistant Examiner*—Maurice Stevens

(74) *Attorney, Agent, or Firm*—Pearson & Pearson, LLP

(57) **CLAIM**

The ornamental design for a throttle control lever, as shown and described.

**DESCRIPTION**

FIG. 1 is a top plan view of the throttle control lever showing my new design;

FIG. 2 is a bottom plan view of the throttle control lever thereof;

FIG. 3 is a front perspective view of the throttle control lever thereof;

FIG. 4 is a right side elevational view of the throttle control lever thereof;

FIG. 5 is a left side elevational view of the throttle control lever thereof;

FIG. 6 is a front elevational view of the throttle control lever thereof; and,

FIG. 7 is a rear elevational view of the throttle control lever thereof.

The broken lines in all of the figures show environmental structure and form no part of the claimed design.

The broken lines in FIG. 1 show environmental structure and form no part of the claimed design.

**1 Claim, 5 Drawing Sheets**

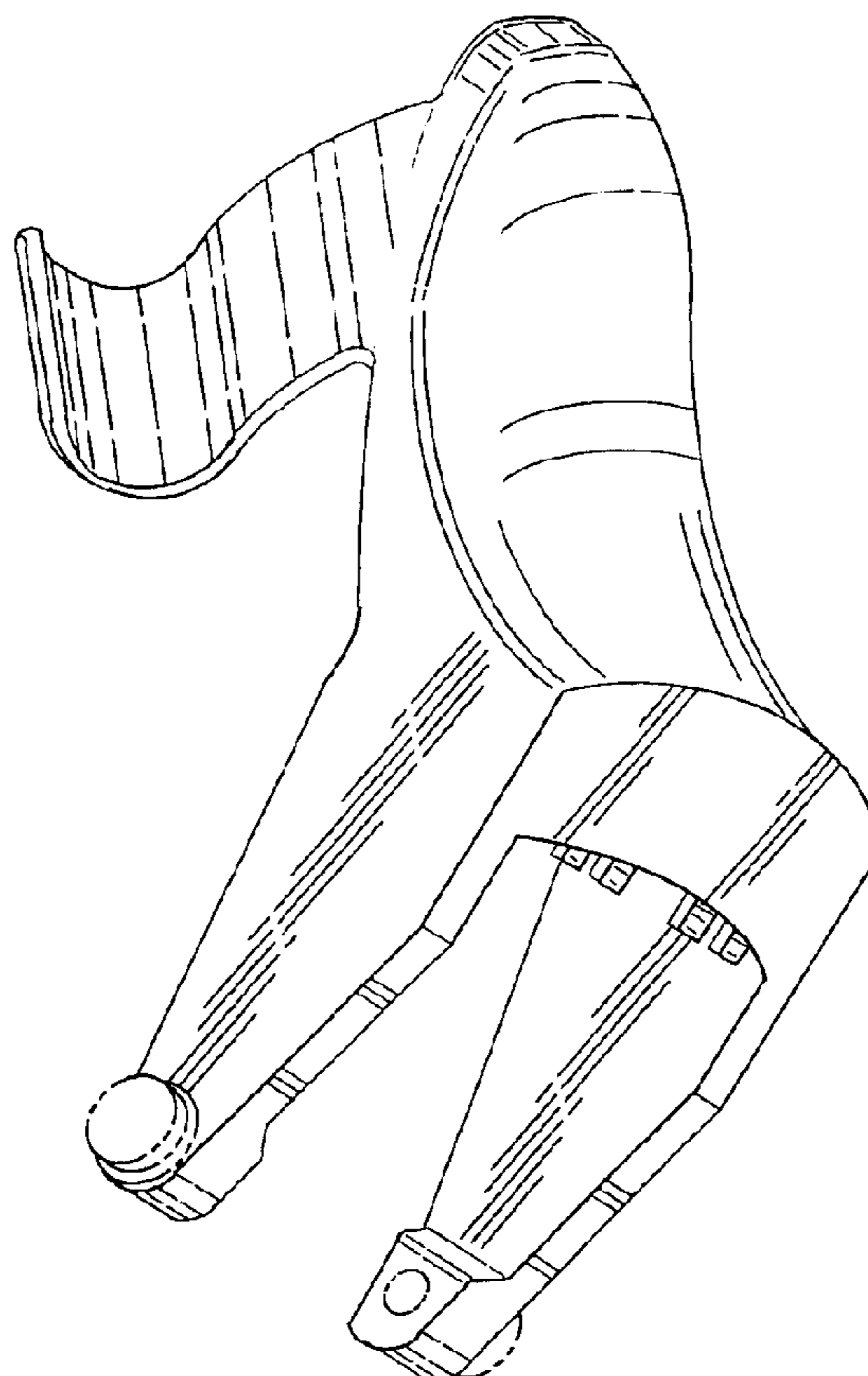

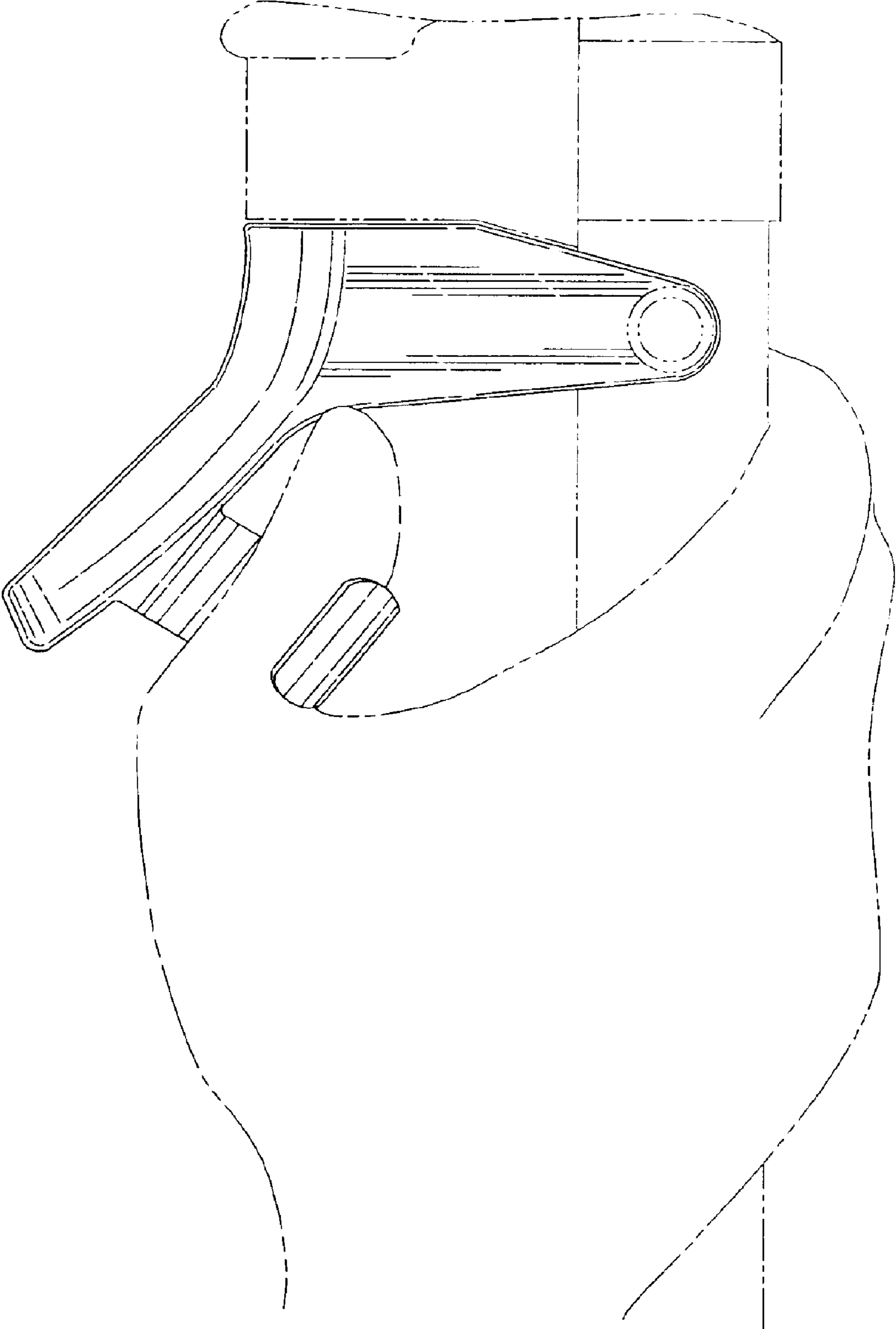

FIG. 1

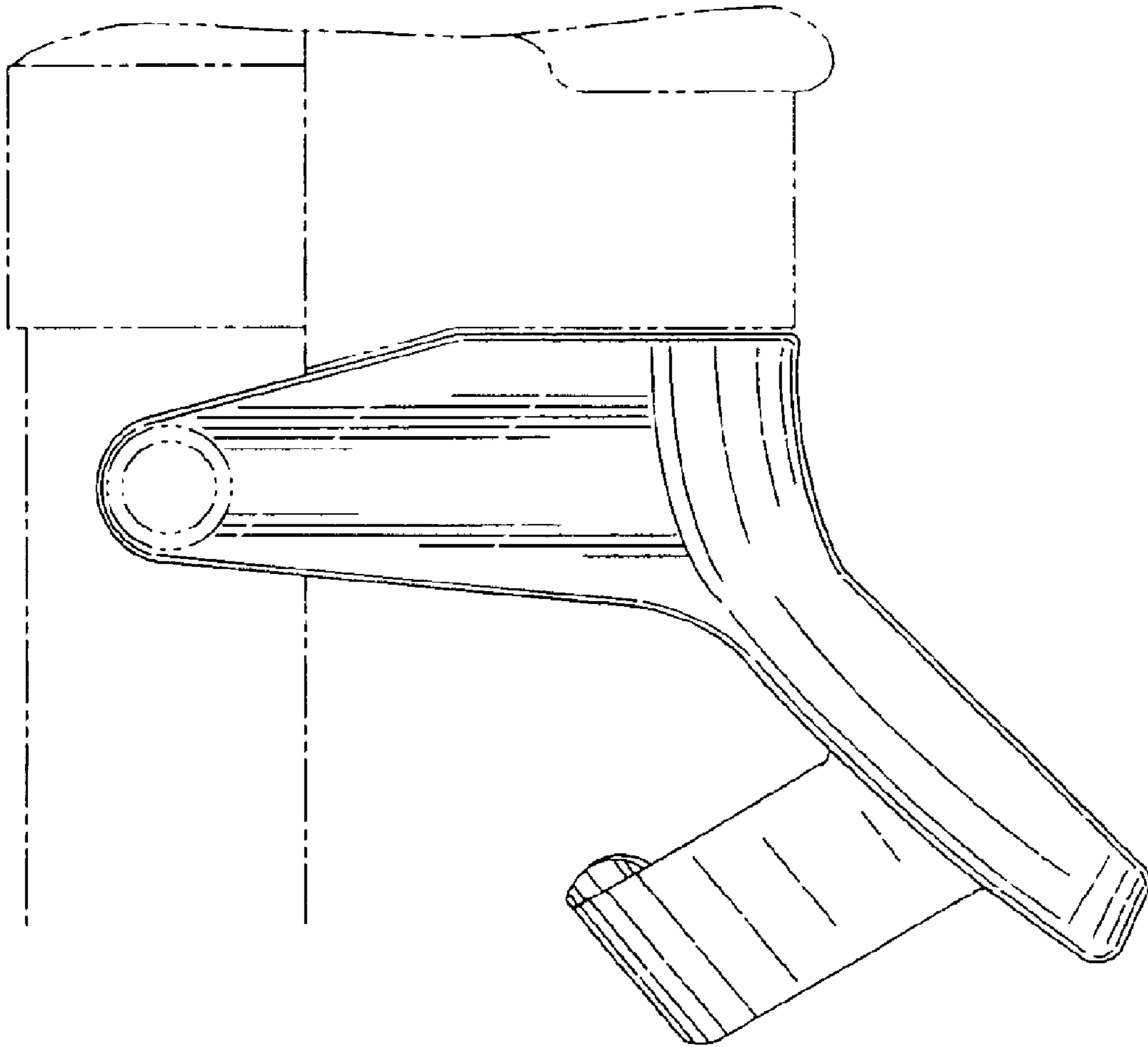

FIG. 2

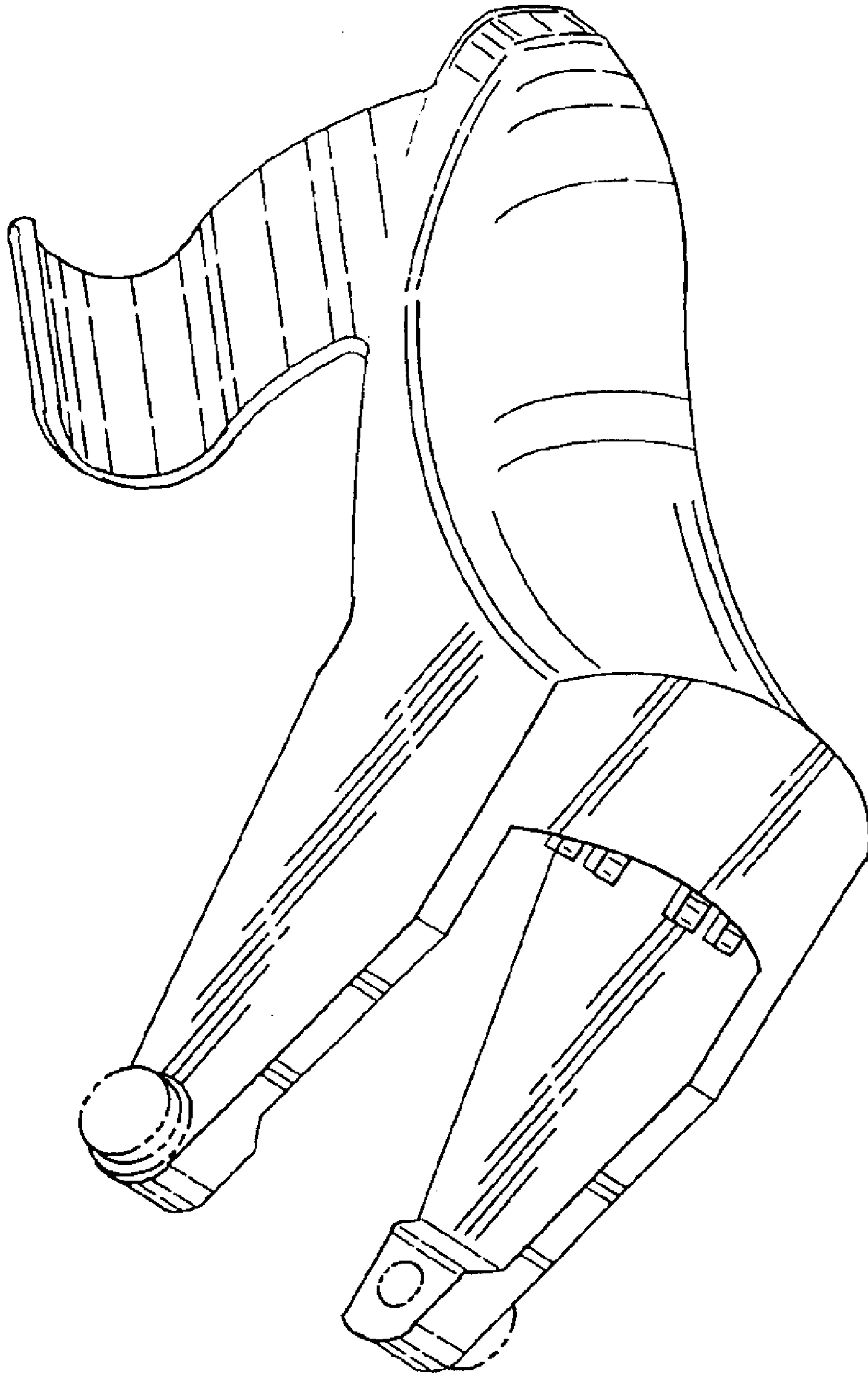

FIG. 3

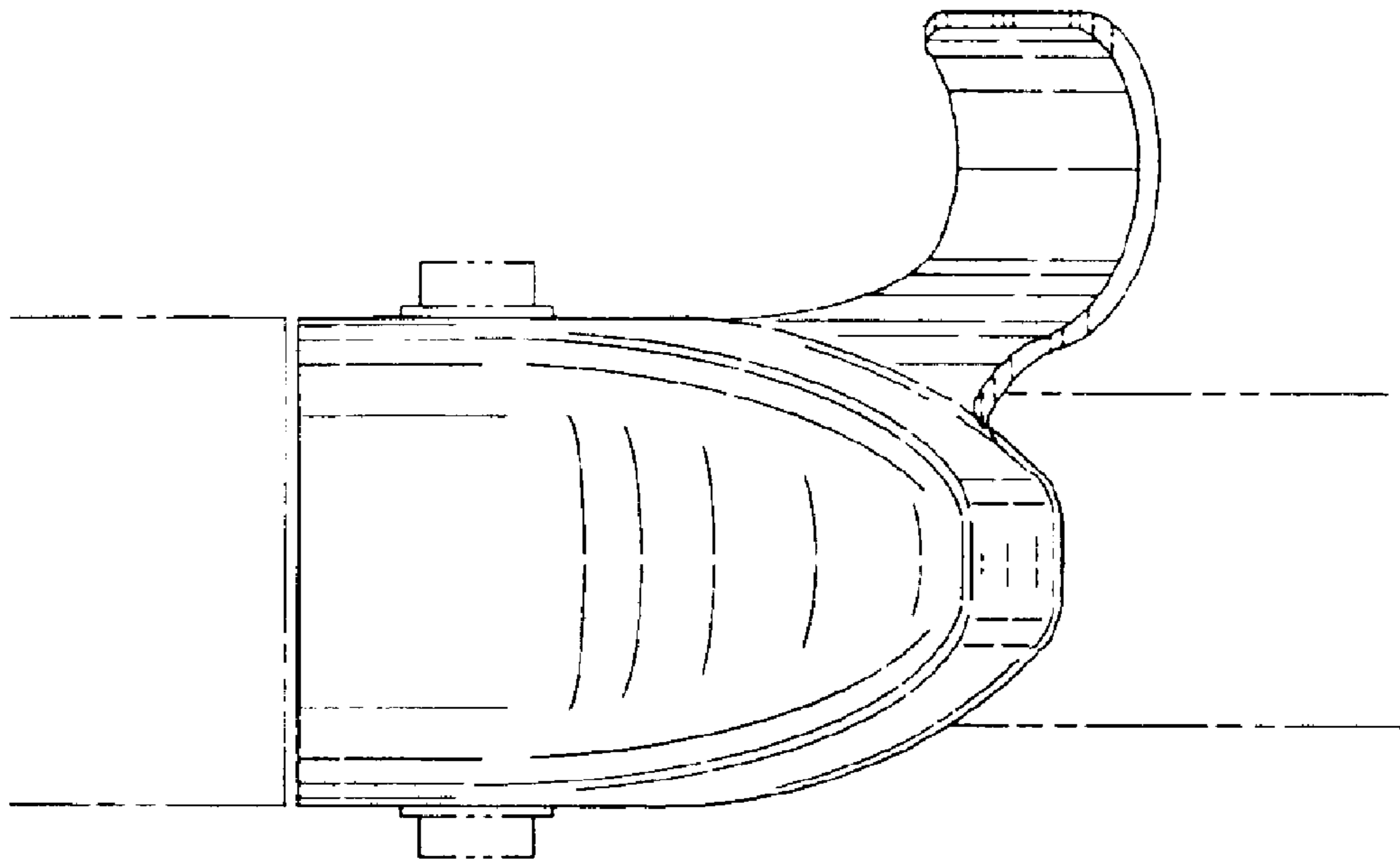

FIG. 4

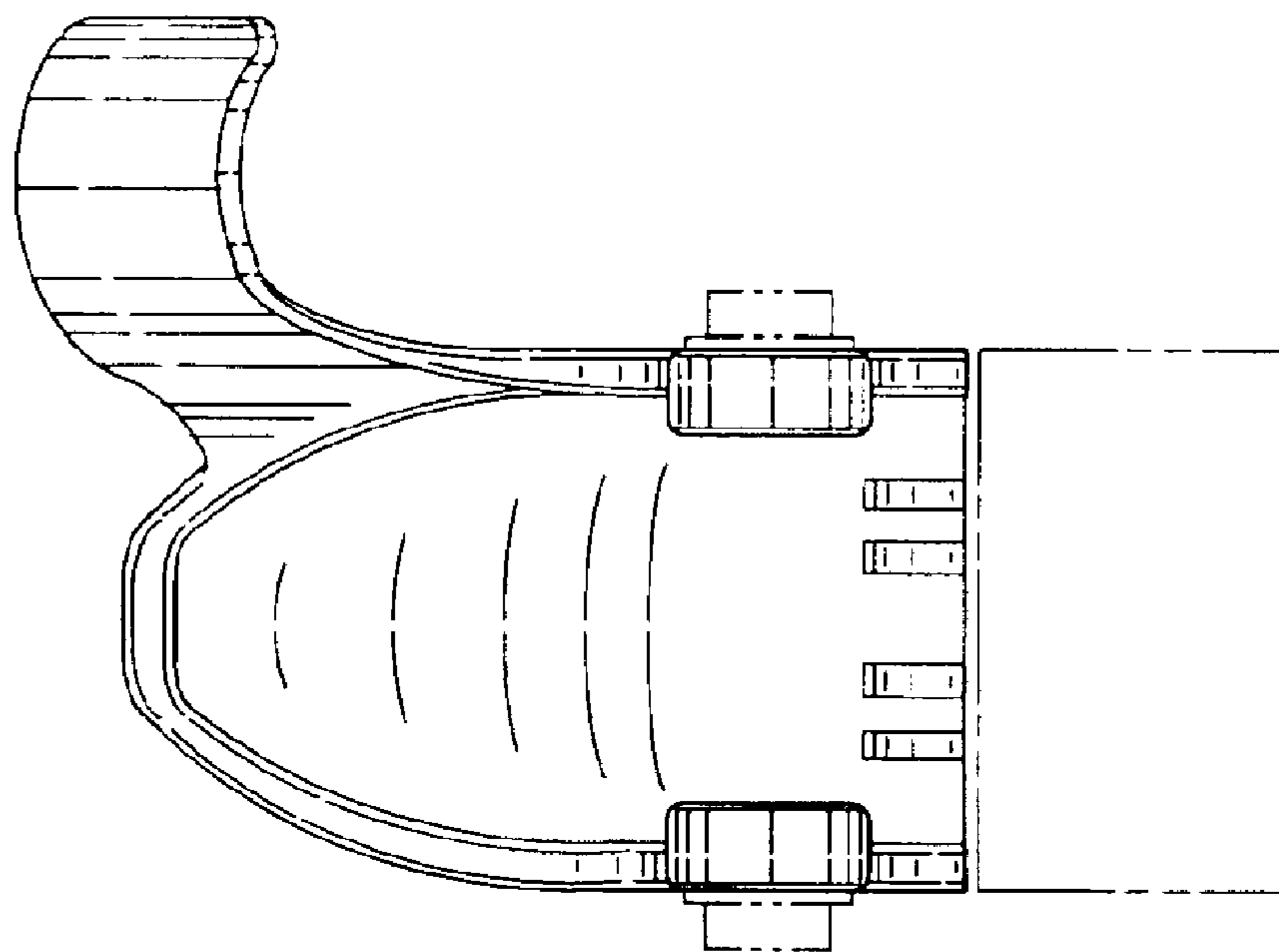

FIG. 5

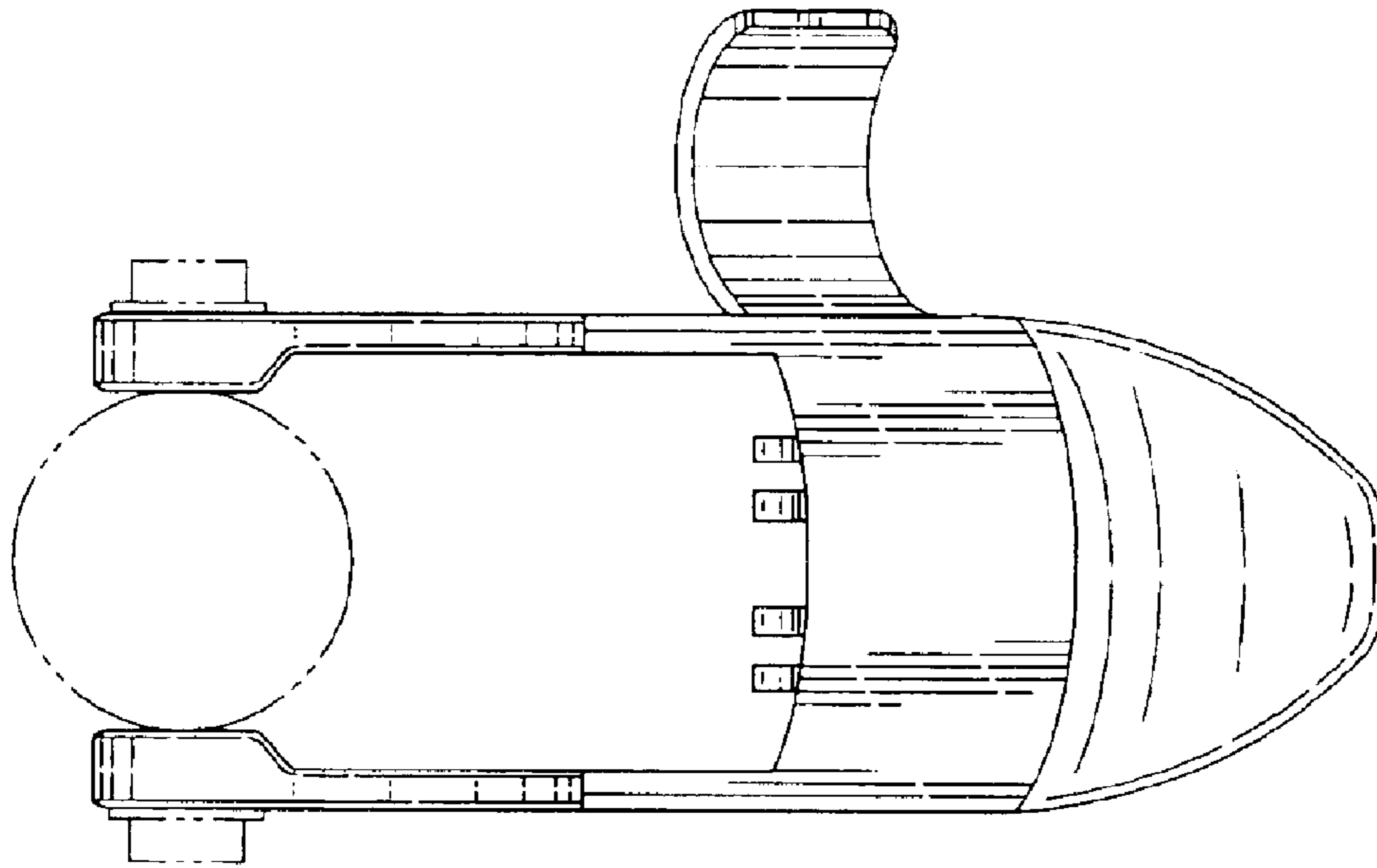

FIG. 6

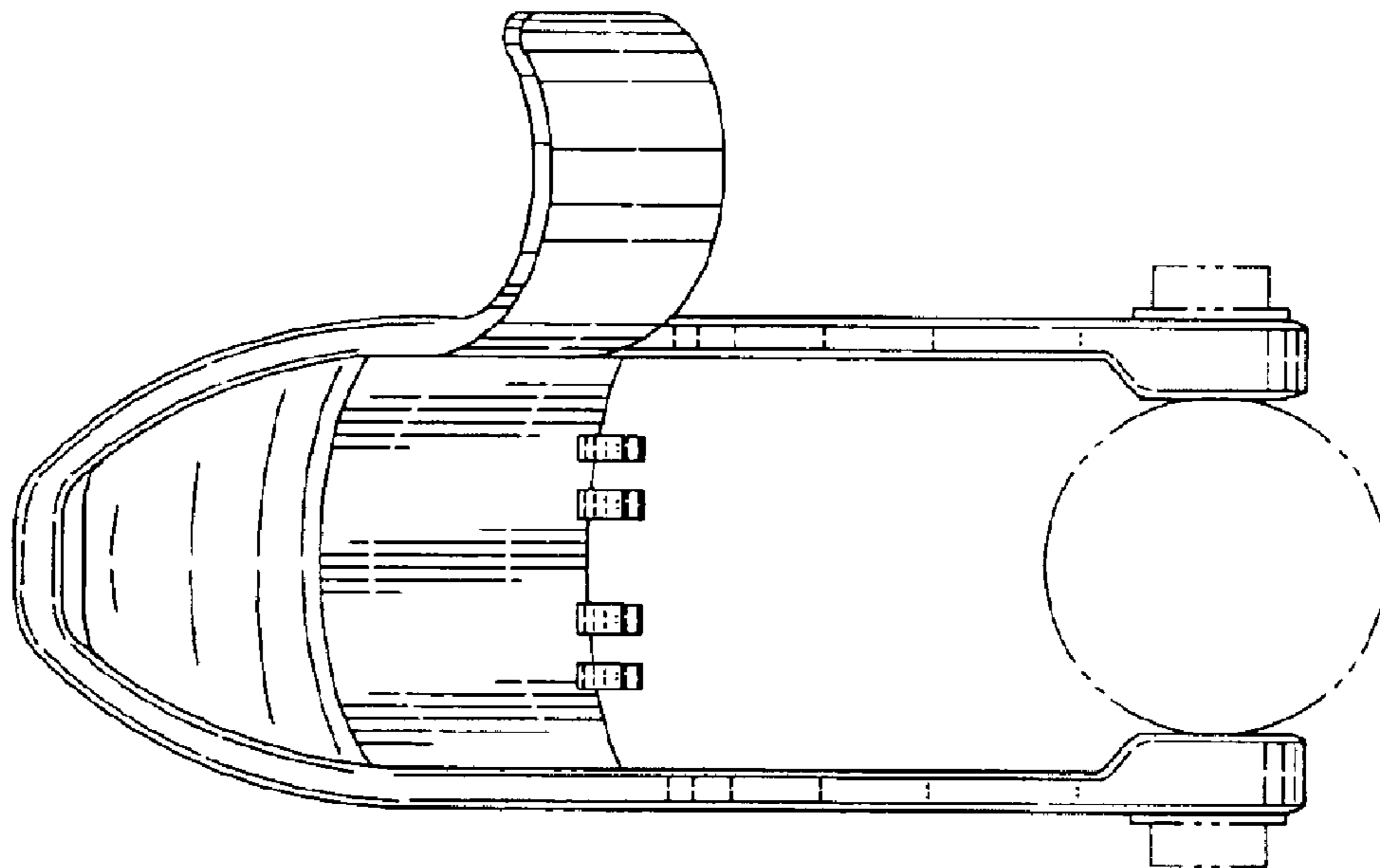

FIG. 7