



US00D518982S

(12) **United States Design Patent**
O'Hare

(10) **Patent No.:** **US D518,982 S**

(45) **Date of Patent:** **** Apr. 18, 2006**

(54) **PEDESTAL**

(75) Inventor: **Timothy M. O'Hare**, Oak Ridge, NC (US)

(73) Assignee: **Thomasville Furniture Industries, Inc.**, Thomasville, NC (US)

(**) Term: **14 Years**

(21) Appl. No.: **29/216,044**

(22) Filed: **Oct. 28, 2004**

(51) **LOC (8) Cl.** **06-06**

(52) **U.S. Cl.** **D6/498; D6/495**

(58) **Field of Classification Search** D6/480-489,
D6/495-499; 108/150, 153.1, 155, 156, 157.1,
108/161; 248/188, 188.1, 188.8, 188.9
See application file for complete search history.

(56) **References Cited**

U.S. PATENT DOCUMENTS

| | | | | | |
|------------|---|---------|---------------|-------|--------|
| D78,457 S | * | 5/1929 | Ekvall | | D6/451 |
| D448,213 S | | 9/2001 | O'Hare et al. | | D6/480 |
| D457,357 S | * | 5/2002 | Vaaler | | D6/480 |
| D460,883 S | | 7/2002 | Stanton | | D6/486 |
| D464,828 S | * | 10/2002 | Vaaler | | D6/480 |
| D470,343 S | | 2/2003 | Stanton | | D6/480 |
| D494,782 S | | 8/2004 | Stanton | | D6/486 |

OTHER PUBLICATIONS

Lane Oct. 28, 1965, p. 61, table.*
Round Pedestal Table, Grand Classics Collection brochure,
Thomasville Furniture Industries, Inc., p. 17, 1993.

Commander's Dining Table, River Roads Collection brochure, Thomasville Furniture Industries, Inc., p. 11, 1998.
Double Pedestal Table, Villa Capri Collection brochure, Thomasville Furniture Industries, Inc., p. 7, date unknown, available as of the filing date.
Double Pedestal Dining Table, Villa Soleil Collection brochure, Thomasville Furniture Industries, Inc., p. 14, 2003.
Regency Brass Inlaid and Brass-Mounted Rosewood Cente Table, Christie's London, Nov. 30, 2000.

* cited by examiner

Primary Examiner—Janice E. Seeger

(74) *Attorney, Agent, or Firm*—Womble Carlyle Sandridge & Rice, PLLC

(57) **CLAIM**

The ornamental design for a pedestal, as shown and described.

DESCRIPTION

FIG. 1 is a perspective view of a pedestal showing my new design;

FIG. 2 is a side elevational view, the opposite side being a mirror image thereof; and,

FIG. 3 is an end elevational view, the opposite end being a mirror image thereof.

The views of the pedestal not shown form no part of the claimed design. The broken lines depicting a round table top and feet represent environmental elements only and form no part of the claimed design.

1 Claim, 3 Drawing Sheets

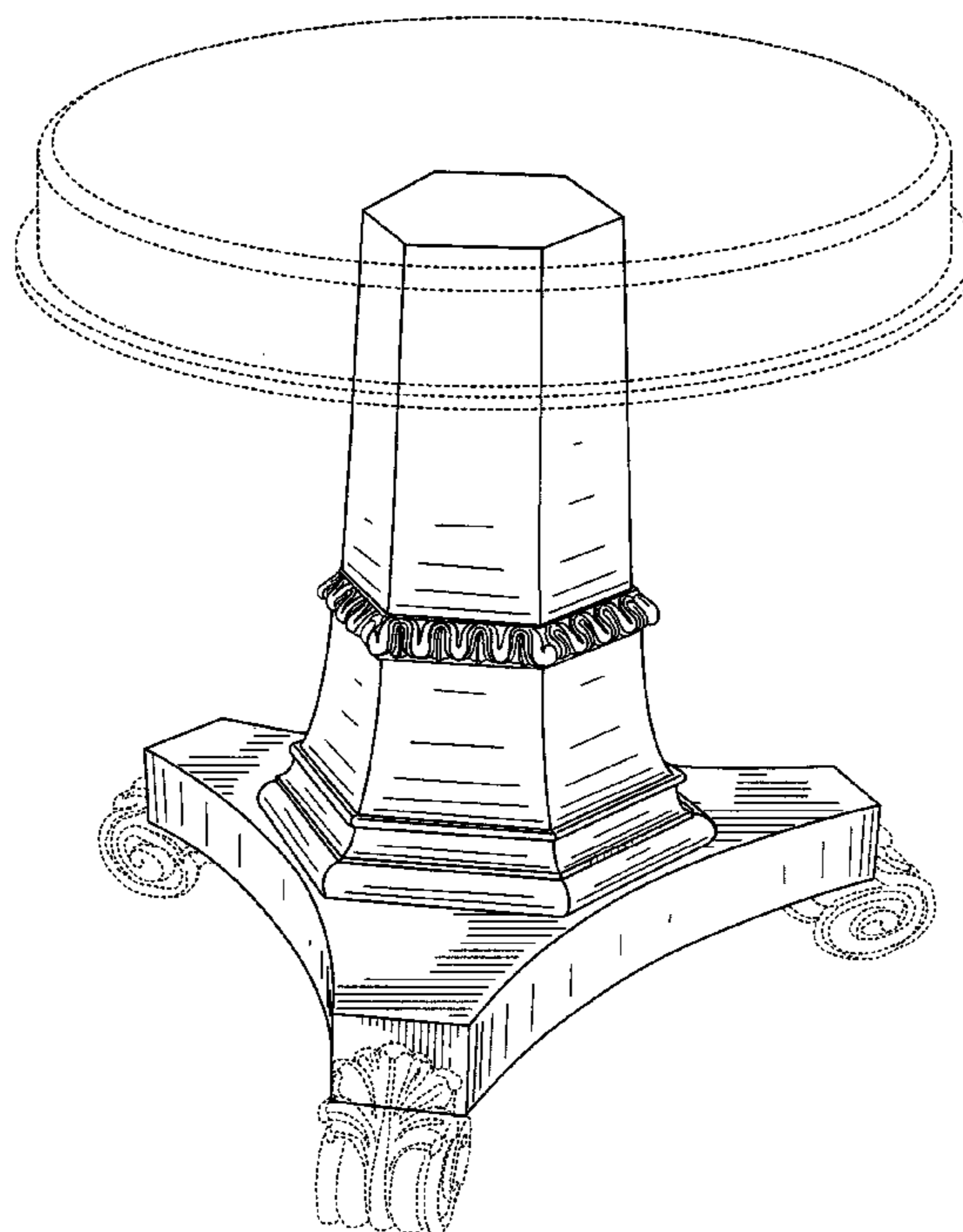

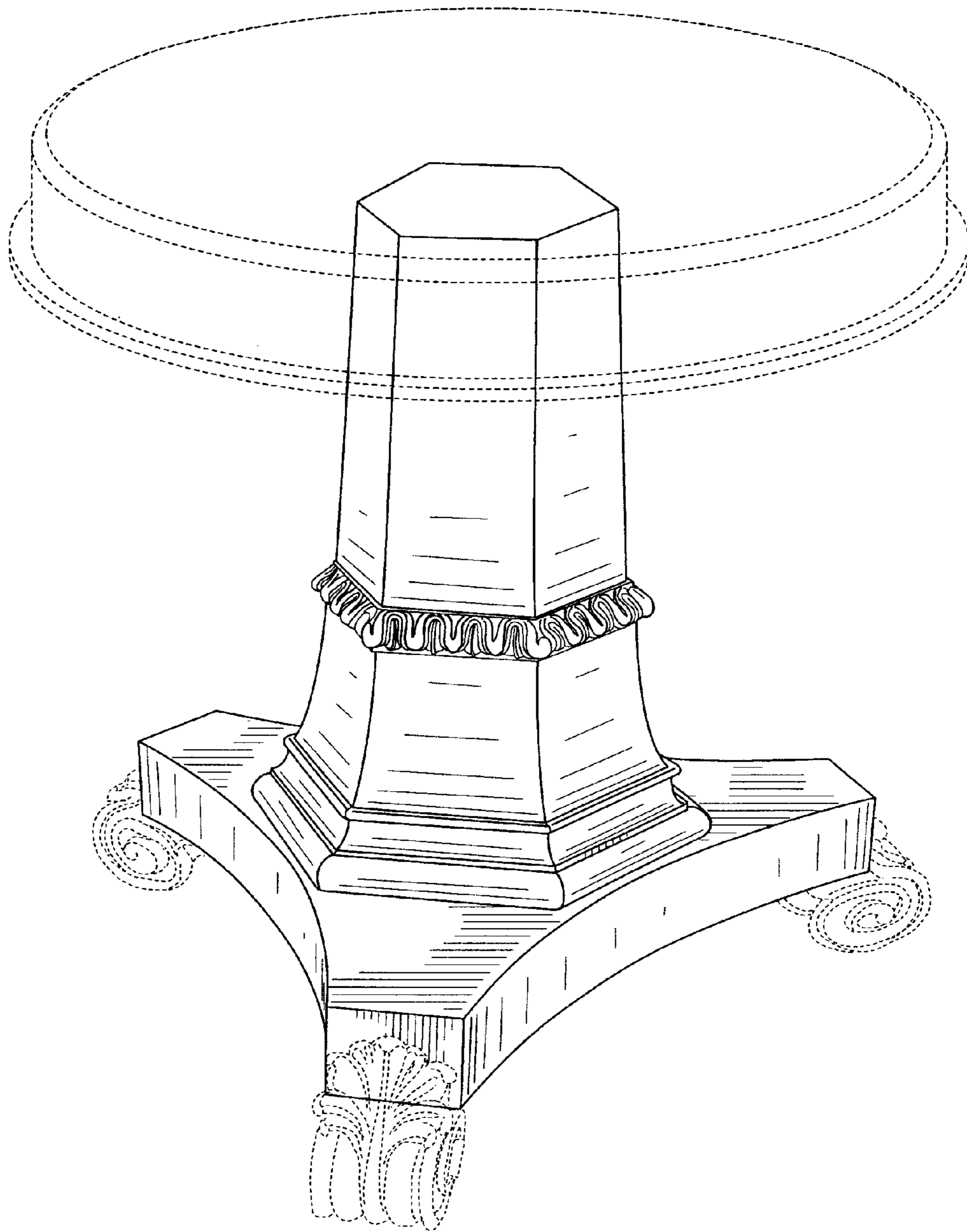

FIG. 1

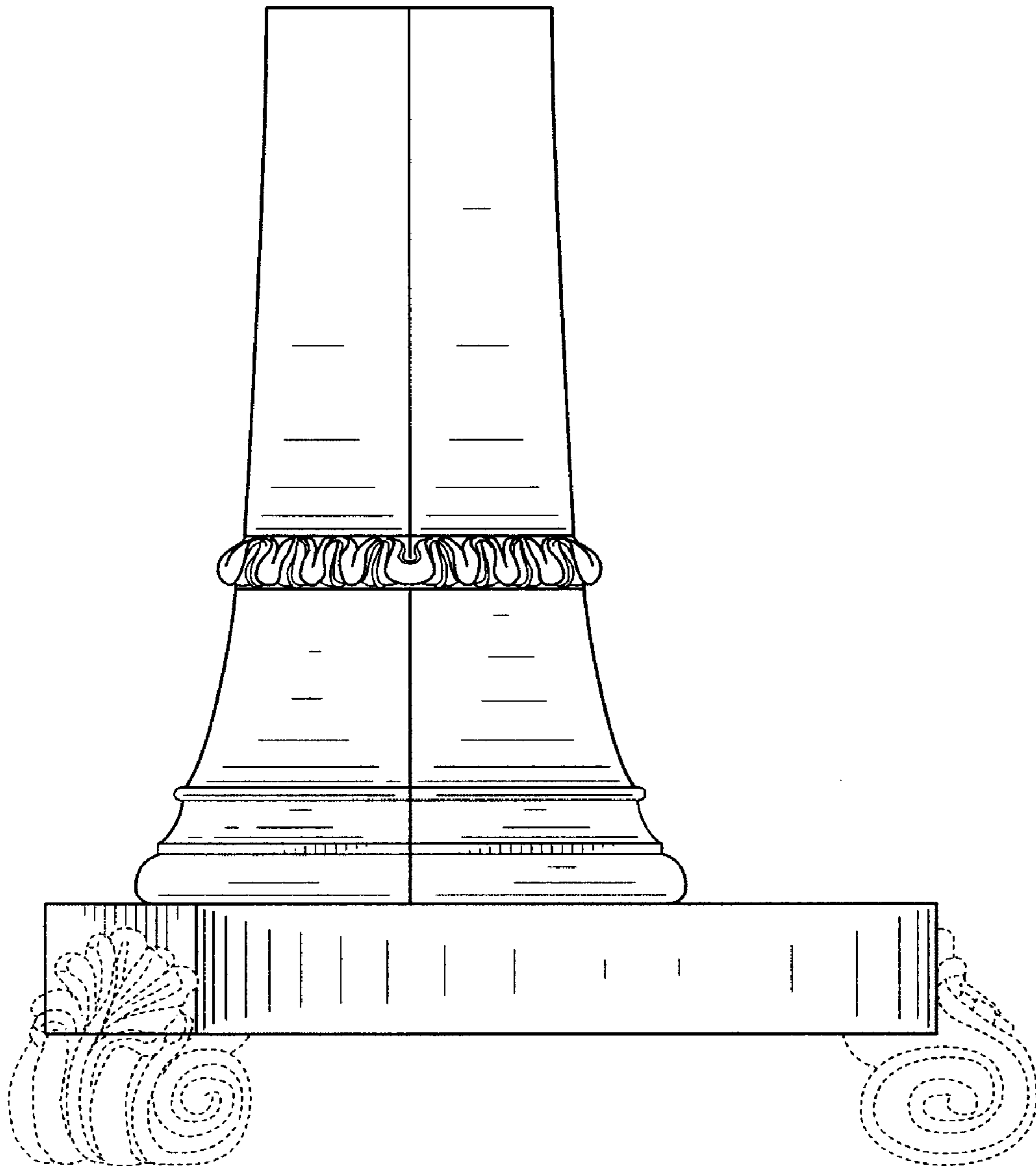

FIG. 2

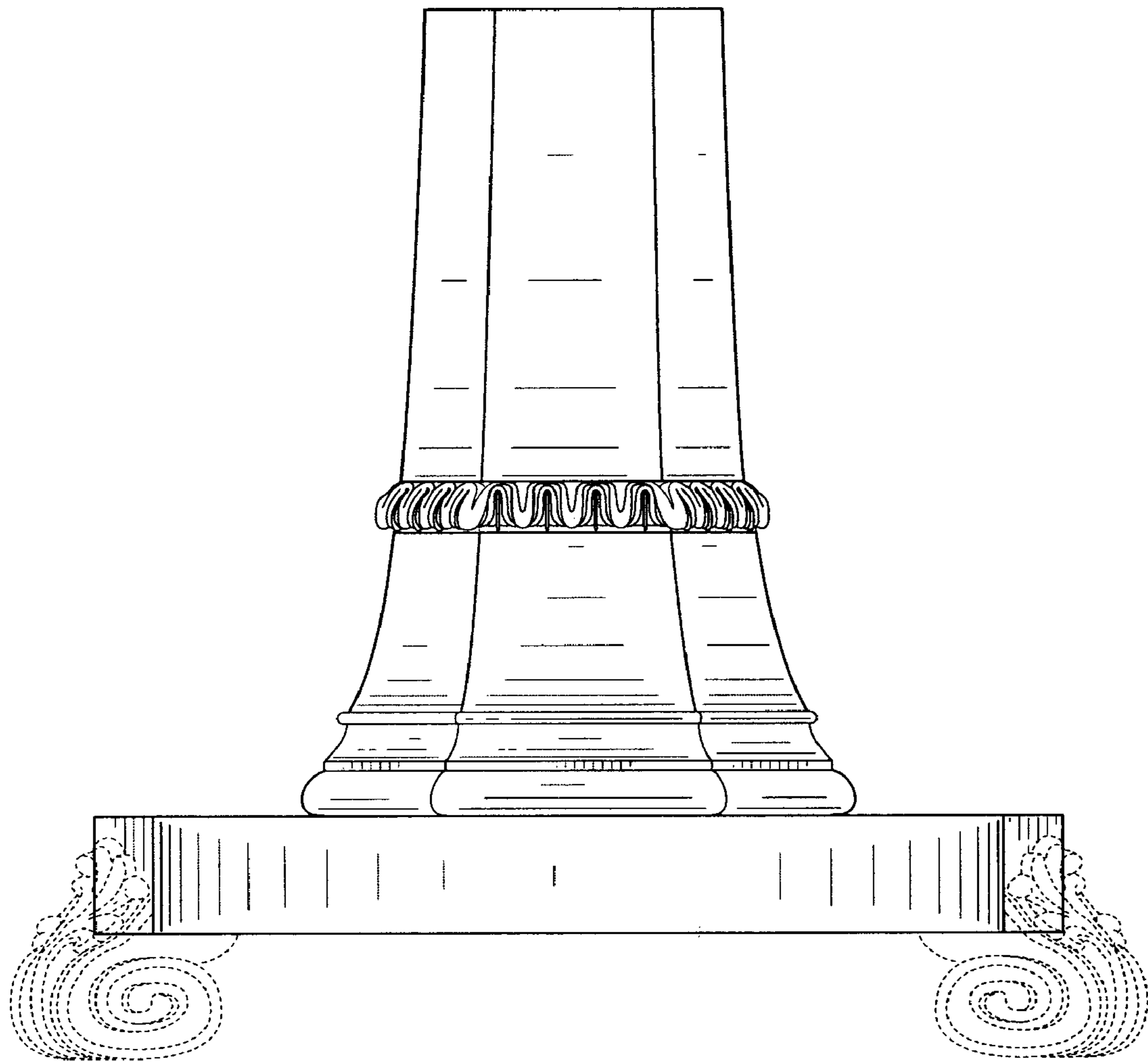

FIG. 3