



US00D518961S

(12) **United States Design Patent**
Armstrong

(10) **Patent No.:** **US D518,961 S**

(45) **Date of Patent:** **** Apr. 18, 2006**

(54) **SHOULDER STRAP FOR A MUSICAL INSTRUMENT, A CASE, A BAG OR THE LIKE**

6,712,614 B1 * 3/2004 Henderson 434/203

FOREIGN PATENT DOCUMENTS

GB 2277627 A * 11/1994

WO WO 94/12965 * 6/1994

* cited by examiner

Primary Examiner—Sandra S. Snapp

(74) *Attorney, Agent, or Firm*—Clayton R. Johnson

(76) **Inventor:** **Timothy D. Armstrong**, 18066 Waco Dr. NW., Anoka, MN (US) 55303

(**) **Term:** **14 Years**

(21) **Appl. No.:** **29/214,039**

(22) **Filed:** **Sep. 27, 2004**

(51) **LOC (8) Cl.** **03-01**

(52) **U.S. Cl.** **D3/327**

(58) **Field of Classification Search** D3/318–328, D3/201; D2/626, 639, 640; D18/6; D17/20; 190/115, 102; 150/107, 108; 224/257, 258, 224/264, 910, 643, 150; 206/315.1; 434/203
See application file for complete search history.

(57) **CLAIM**

The ornamental design for a shoulder strap for a musical instrument, a case, a bag or the like, as shown and described.

DESCRIPTION

FIG. 1 is a perspective view of a shoulder strap of my design for a musical instrument, a case, a bag or the like extended over one shoulder of a person supporting a musical instrument, the person and musical instrument not forming any part of the claimed design;

FIG. 2 is a perspective view of a shoulder strap of my design for a musical instrument, a case, a bag or the like extended over one shoulder of a person supporting a carrying case, the person, carrying case and snap fastener not forming any part of the claimed design;

FIG. 3 is a front elevation view of a shoulder strap of my design for a musical instrument, a case, a bag or the like;

FIG. 4 is a left side view thereof;

FIG. 5 is a rear elevation view thereof;

FIG. 6 is a right side view thereof;

FIG. 7 is a top plan view thereof; and,

FIG. 8 is a bottom plan view thereof.

The broken line showing of a human form in FIGS. 1 and 2, the guitar in FIG. 1 and the snap fastener in FIG. 2 form no part of the claimed design.

(56) **References Cited**

U.S. PATENT DOCUMENTS

D181,754 S	*	12/1957	Schott	D18/6
3,731,401 A	*	5/1973	Kojima	434/203
D235,460 S	*	6/1975	Lovelace et al.	D3/327
D247,931 S	*	5/1978	Naysmith	D29/122
4,210,093 A	*	7/1980	Baker	116/222
D302,607 S	*	8/1989	Krebs et al.	D29/122
D325,470 S	*	4/1992	Harms	D3/327
D337,197 S	*	7/1993	Krutsch et al.	D3/327
5,395,245 A	*	3/1995	Heinz	434/204
D408,435 S	*	4/1999	Gettings	D17/20
D409,648 S	*	5/1999	Gettings	D17/20
D415,785 S	*	10/1999	Gettings	D17/20
D423,782 S	*	5/2000	Ammerman et al.	D3/327
6,220,492 B1	*	4/2001	Huang	224/264
D448,170 S	*	9/2001	Ammerman et al.	D3/327
6,561,415 B2	*	5/2003	Grant	235/61 R

1 Claim, 2 Drawing Sheets

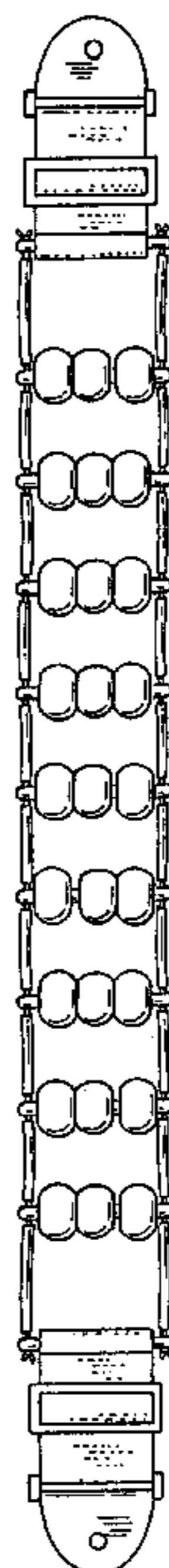

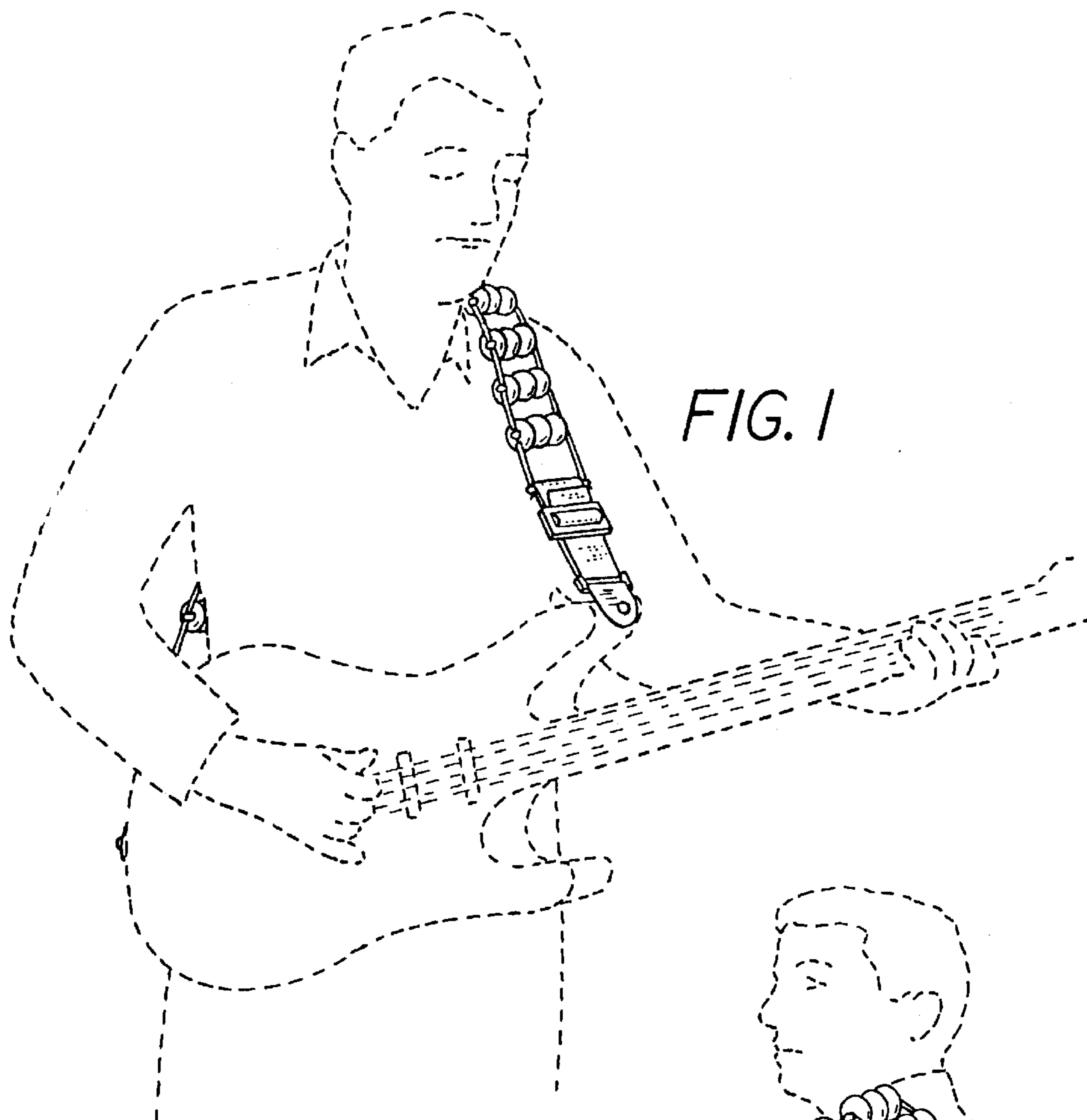

FIG. 2

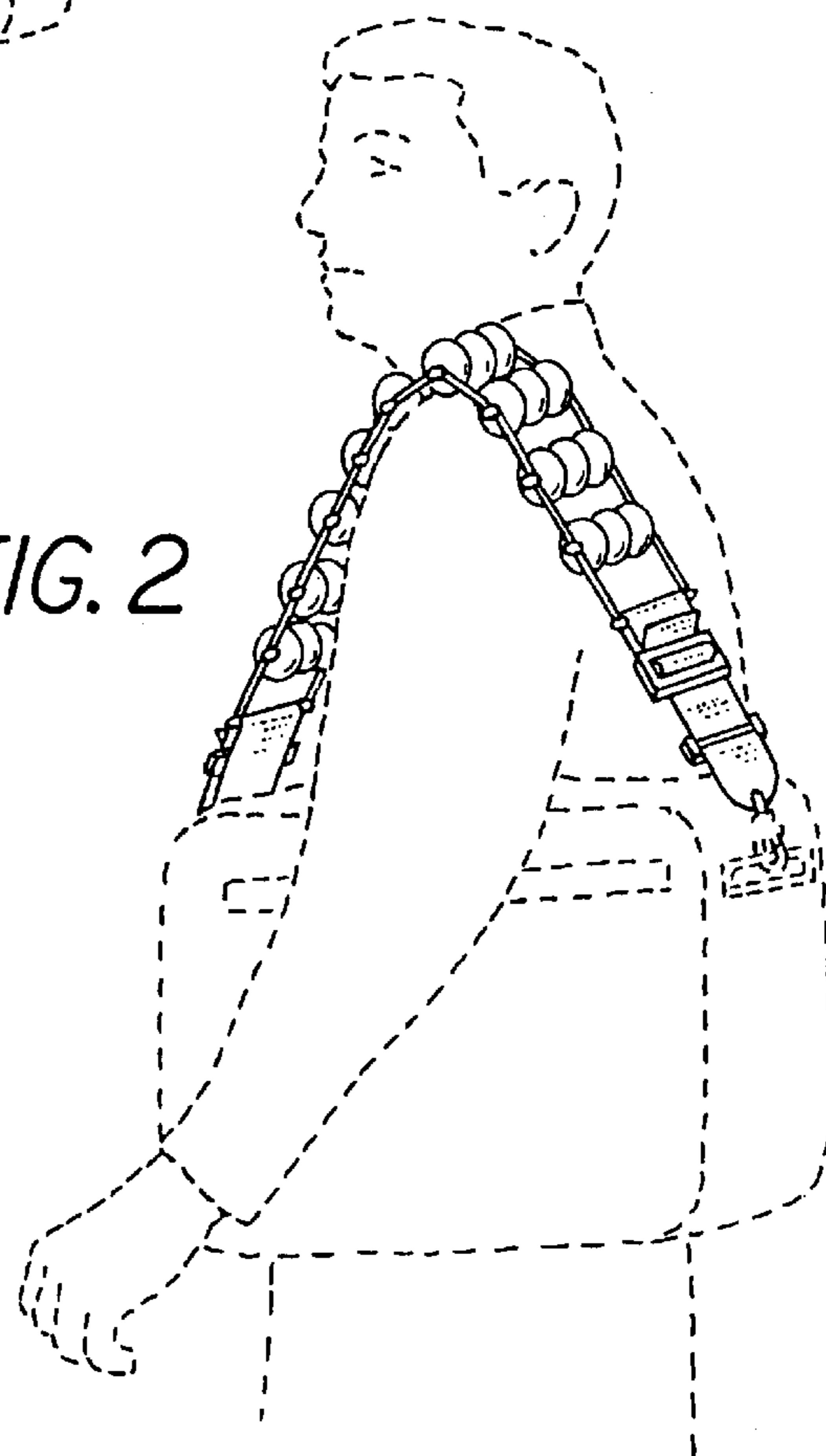

FIG. 3

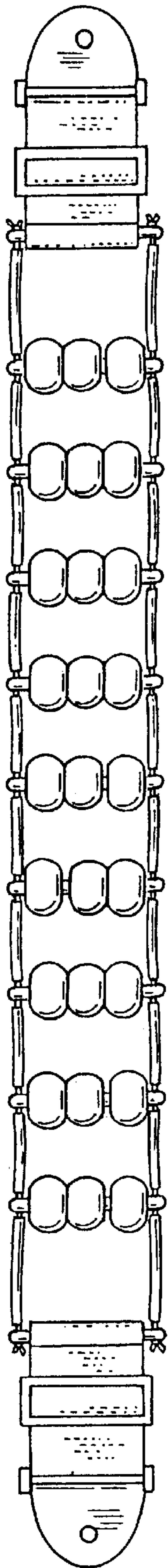

FIG. 4

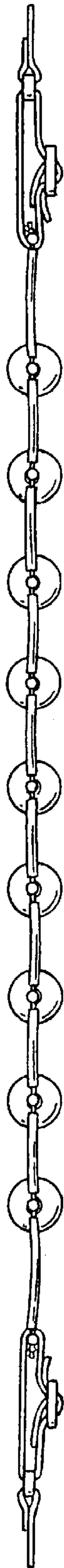

FIG. 5

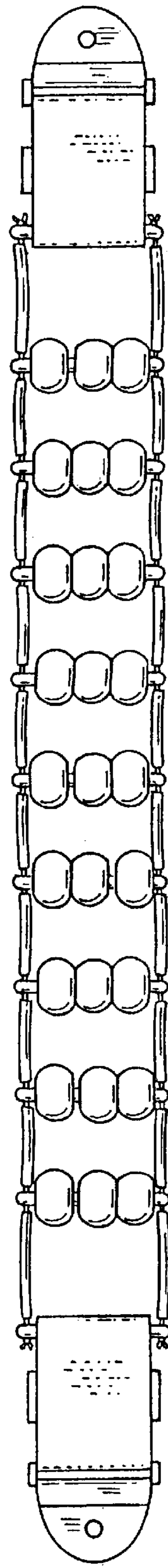

FIG. 6



FIG. 7



FIG. 8

