



US00D518760S

(12) **United States Design Patent**
Johnson

(10) **Patent No.:** **US D518,760 S**

(45) **Date of Patent:** **** Apr. 11, 2006**

(54) **MIDFRAME COVER FOR A MOTORCYCLE**

(75) Inventor: **Keith E. Johnson**, Hudson, WI (US)

(73) Assignee: **Kuryakyn Holdings, Inc.**, Somerset, WI (US)

(**) Term: **14 Years**

(21) Appl. No.: **29/215,506**

(22) Filed: **Oct. 20, 2004**

(51) **LOC (8) Cl.** **12-11**

(52) **U.S. Cl.** **D12/126**

(58) **Field of Classification Search** D12/110,
D12/126, 114, 190, 223; 180/219, 225; 280/288.4,
280/304.3, 304.4

See application file for complete search history.

(56) **References Cited**

PUBLICATIONS

Custom Chrome 1998 catalog, Doss Chrome Seat Rail Covers for Dresser Models and Under-Seat Chrome Frame Covers on p. 15.57.*

* cited by examiner

Primary Examiner—Alan P. Douglas

Assistant Examiner—Linda Brooks

(74) *Attorney, Agent, or Firm*—Westman, Champlin & Kelly, P.A.

(57) **CLAIM**

The ornamental design for a midframe cover for a motorcycle, as shown and described.

DESCRIPTION

FIG. 1 is a right side view of a midframe cover for a motorcycle embodying my new design with a motorcycle midframe shown in dotted lines;

FIG. 2 is a top plan view;

FIG. 3 is a left side view thereof;

FIG. 4 is a rear elevational view thereof;

FIG. 5 is a front elevational view thereof;

FIG. 6 is a left side elevational view thereof; and,

FIG. 7 is a bottom plan view thereof, the dotted line representations form no part of the claimed design.

The broken line boundaries defining the edge of the circular openings form no part of the claim design.

1 Claim, 6 Drawing Sheets

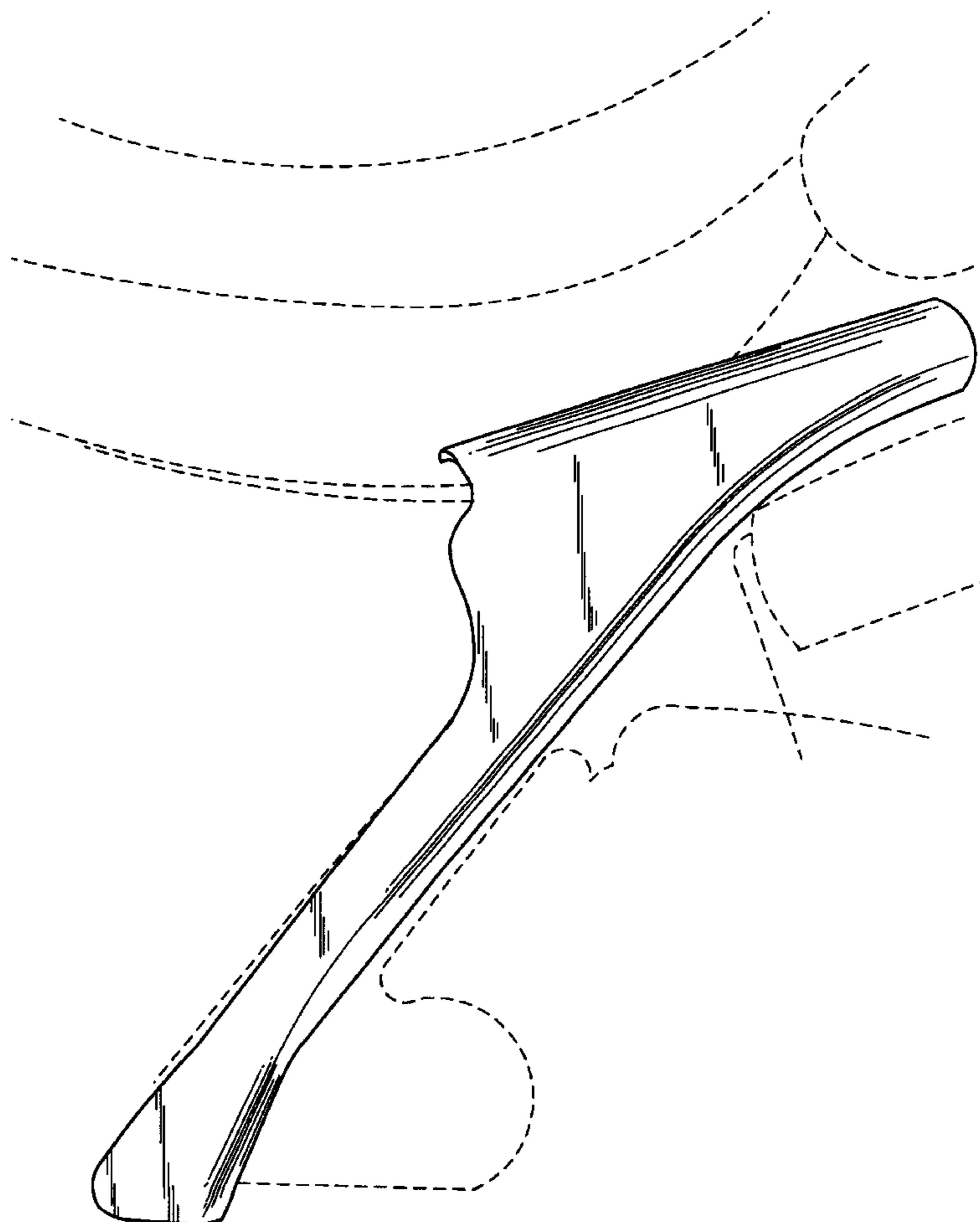

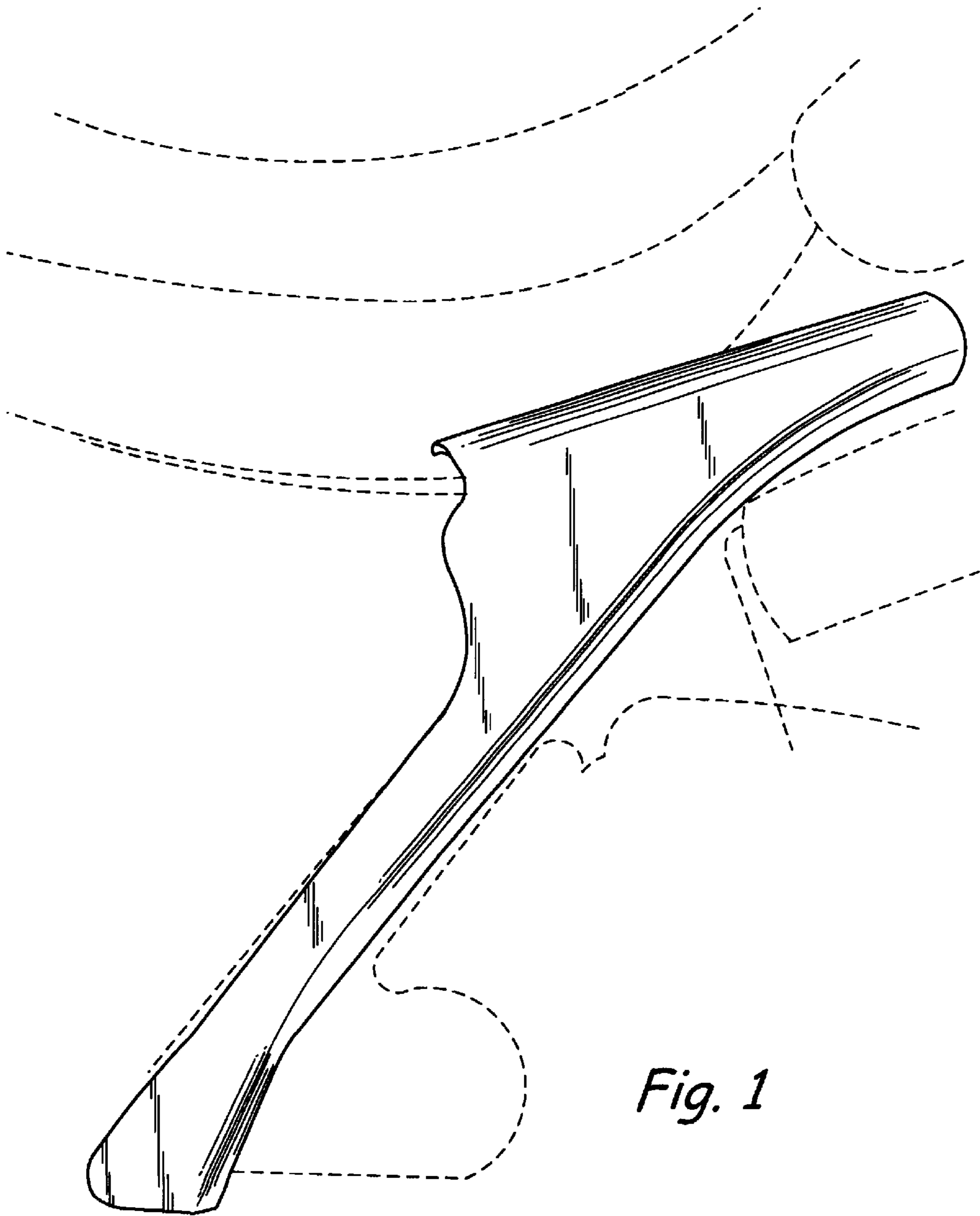

Fig. 1

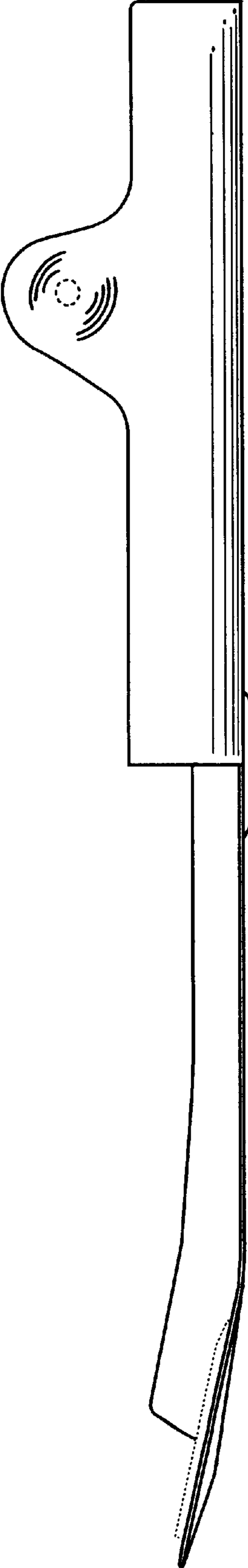

Fig. 2

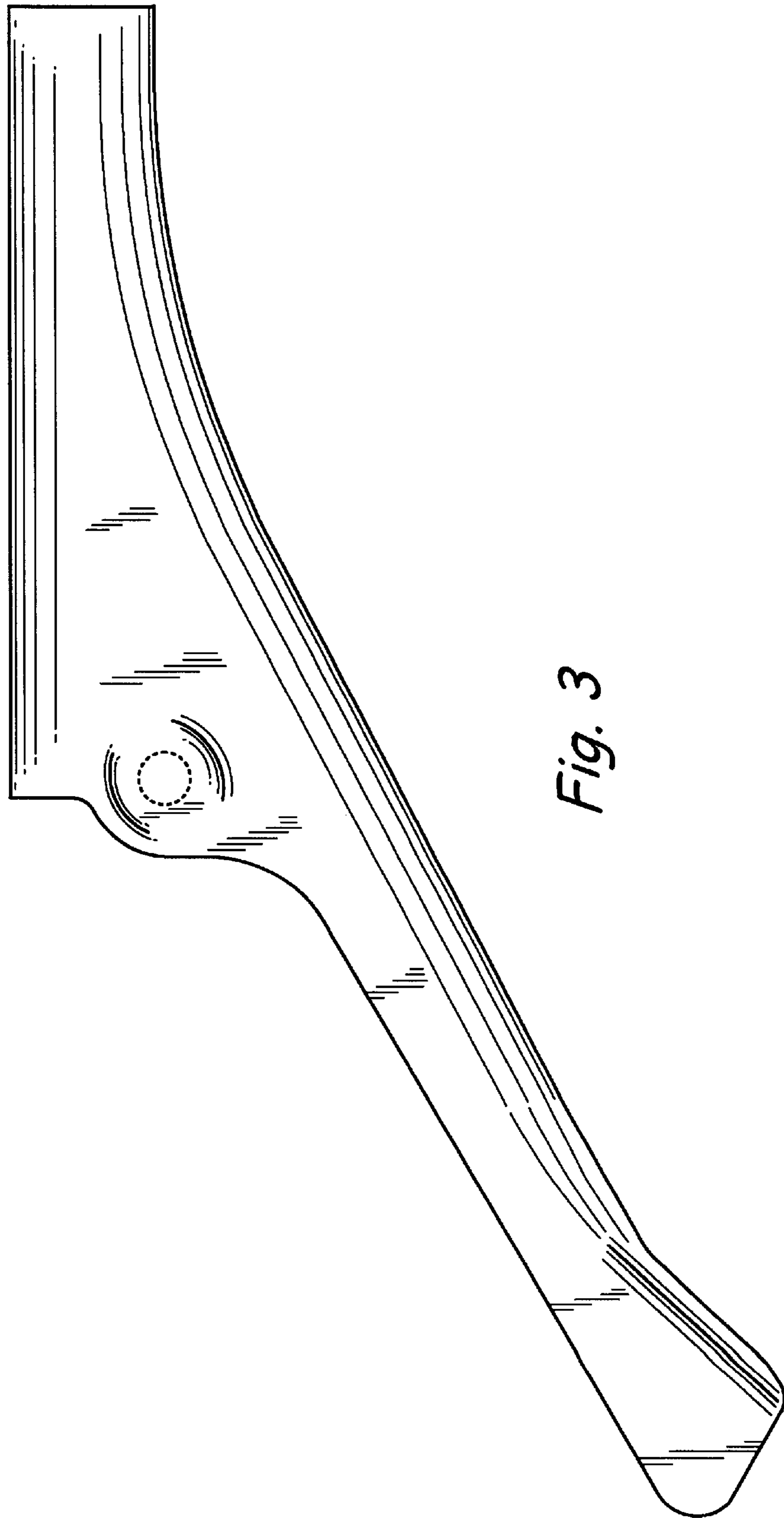

Fig. 3

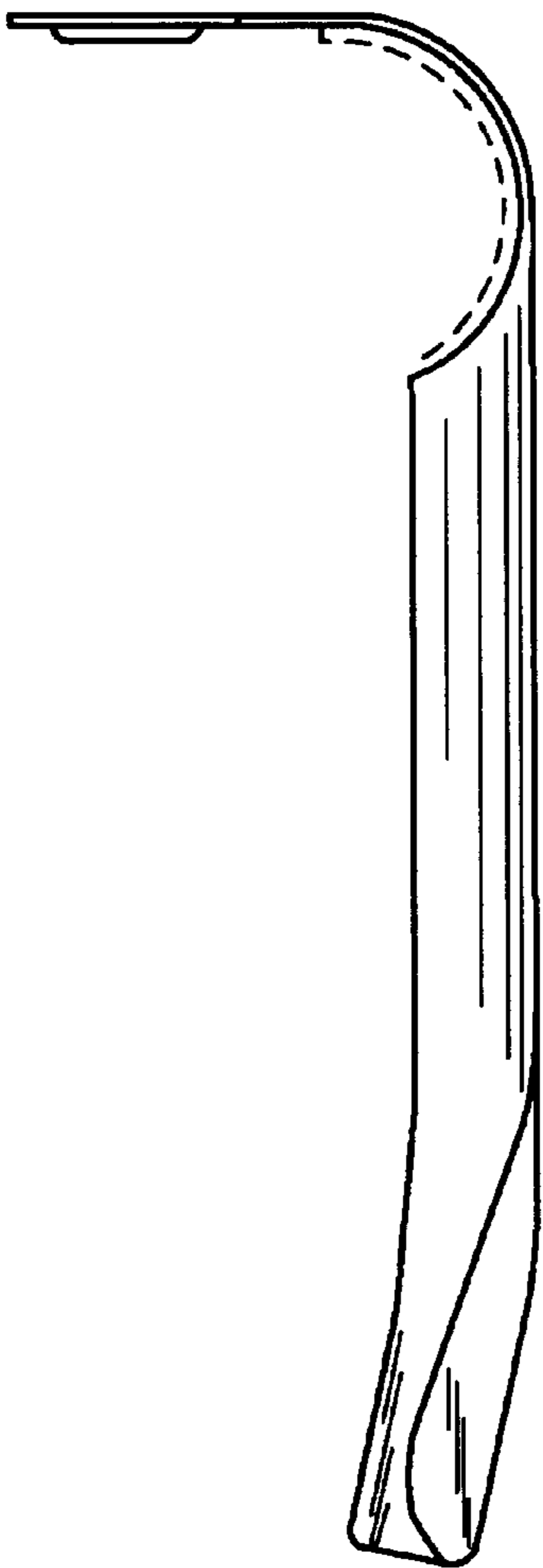

Fig. 4

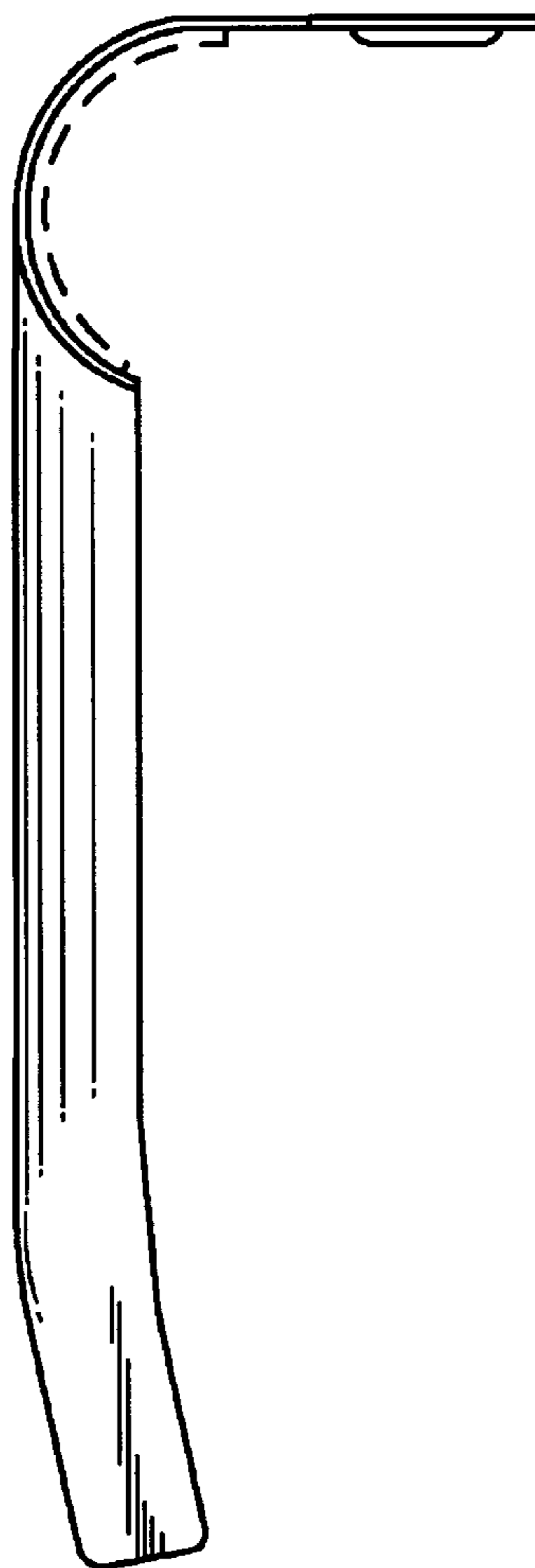

Fig. 5

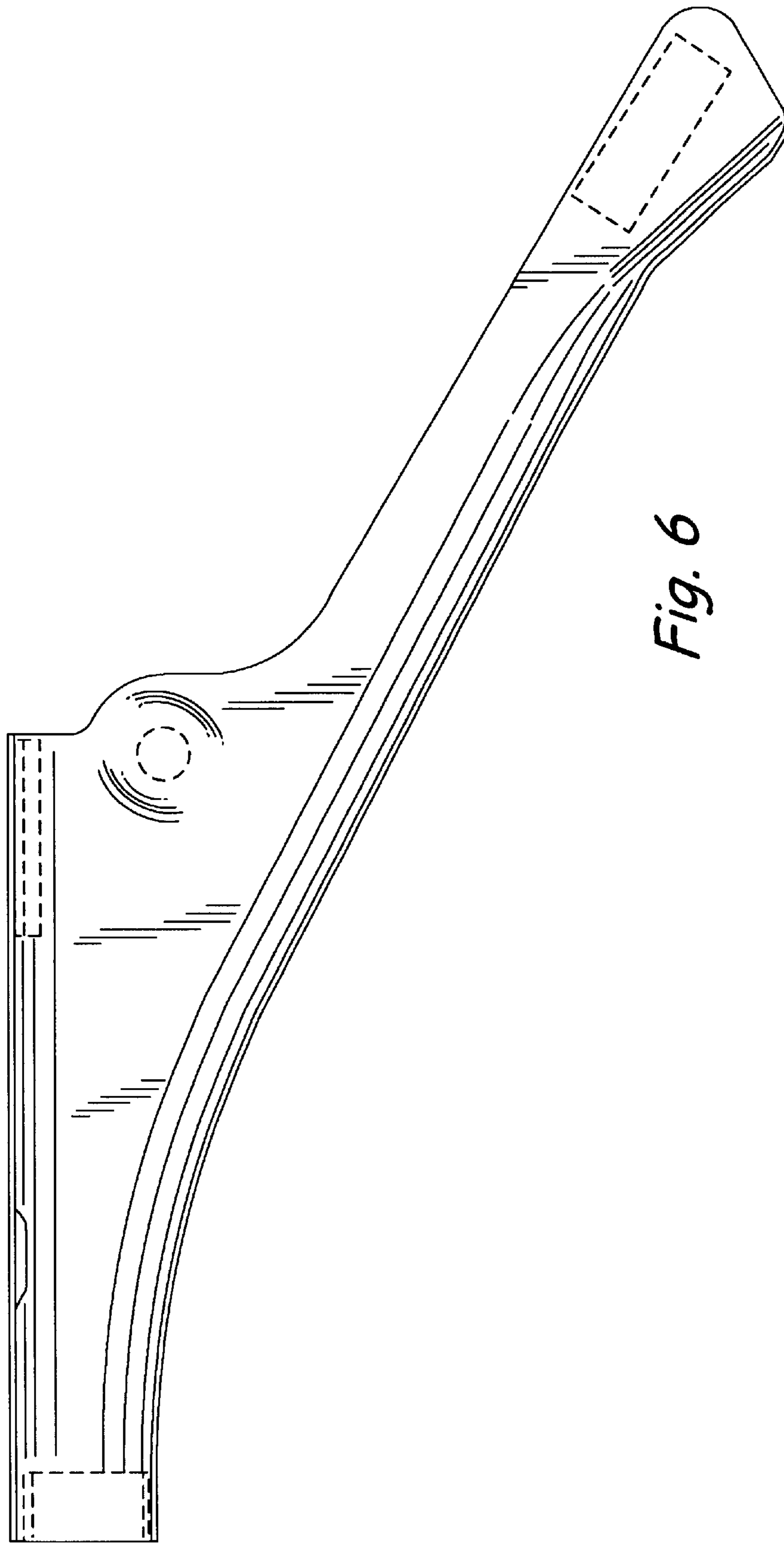

Fig. 6

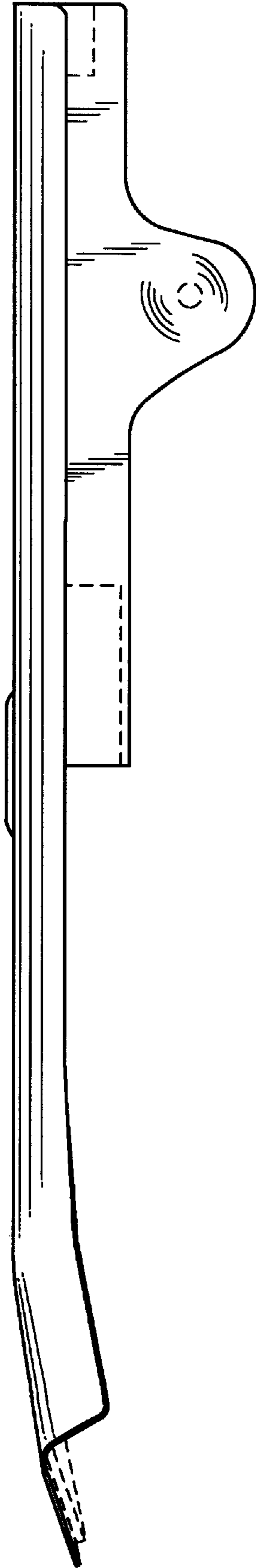

Fig. 7