



US00D518424S

(12) **United States Design Patent**  
**Clark et al.**

(10) **Patent No.:** **US D518,424 S**

(45) **Date of Patent:** **\*\* Apr. 4, 2006**

(54) **VEHICLE BUMPER**

(75) Inventors: **Gordon Clark**, Seattle, WA (US);  
**Gregory S. Hall**, Woodinville, WA  
(US); **Wayne K. Simons**, Kent, WA  
(US); **Steven H. Hovind**, Bellevue, WA  
(US); **Gerald J. Angelo**, Bellevue, WA  
(US); **Larry F. Gulan**, Seattle, WA  
(US)

(73) Assignee: **PACCAR Inc.**, Bellevue, WA (US)

(\*\*) Term: **14 Years**

(21) Appl. No.: **29/225,509**

(22) Filed: **Mar. 15, 2005**

(51) **LOC (8) Cl.** ..... **12-16**

(52) **U.S. Cl.** ..... **D12/169**

(58) **Field of Classification Search** ..... D12/90-92,  
D12/86, 169, 196, 163; 296/180.1, 180.2;  
293/102, 113, 115, 117, 120

See application file for complete search history.

(56) **References Cited**

U.S. PATENT DOCUMENTS

D411,140 S	6/1999	Meryman et al.	
D423,990 S	5/2000	Meryman et al.	
D475,663 S	* 6/2003	Chiang	D12/169
D475,664 S	* 6/2003	Chiang	D12/169
D478,027 S	* 8/2003	Chiang	D12/169
D478,028 S	* 8/2003	Chiang	D12/169
D483,707 S	* 12/2003	Satou	D12/169

D488,749 S	* 4/2004	Ikuma et al.	D12/169
D492,628 S	* 7/2004	Bond et al.	D12/169
D498,716 S	* 11/2004	Maeda et al.	D12/169

\* cited by examiner

*Primary Examiner*—Melody N. Brown

(74) *Attorney, Agent, or Firm*—Christensen O'Connor  
Johnson Kindness PLLC

(57) **CLAIM**

The ornamental design for a vehicle bumper, as shown and described.

**DESCRIPTION**

FIG. 1 is a front perspective view of a vehicle bumper showing our new design;

FIG. 2 is a front elevational view thereof;

FIG. 3 is a rear elevational view thereof;

FIG. 4 is a bottom plan view thereof;

FIG. 5 is a top plan view thereof;

FIG. 6 is a left side elevational view thereof;

FIG. 7 is a right side elevational view thereof;

FIG. 8 is a front perspective view of a second embodiment of a vehicle bumper showing our new design;

FIG. 9 is a front elevational view of FIG. 8;

FIG. 10 is a rear elevational view of FIG. 8;

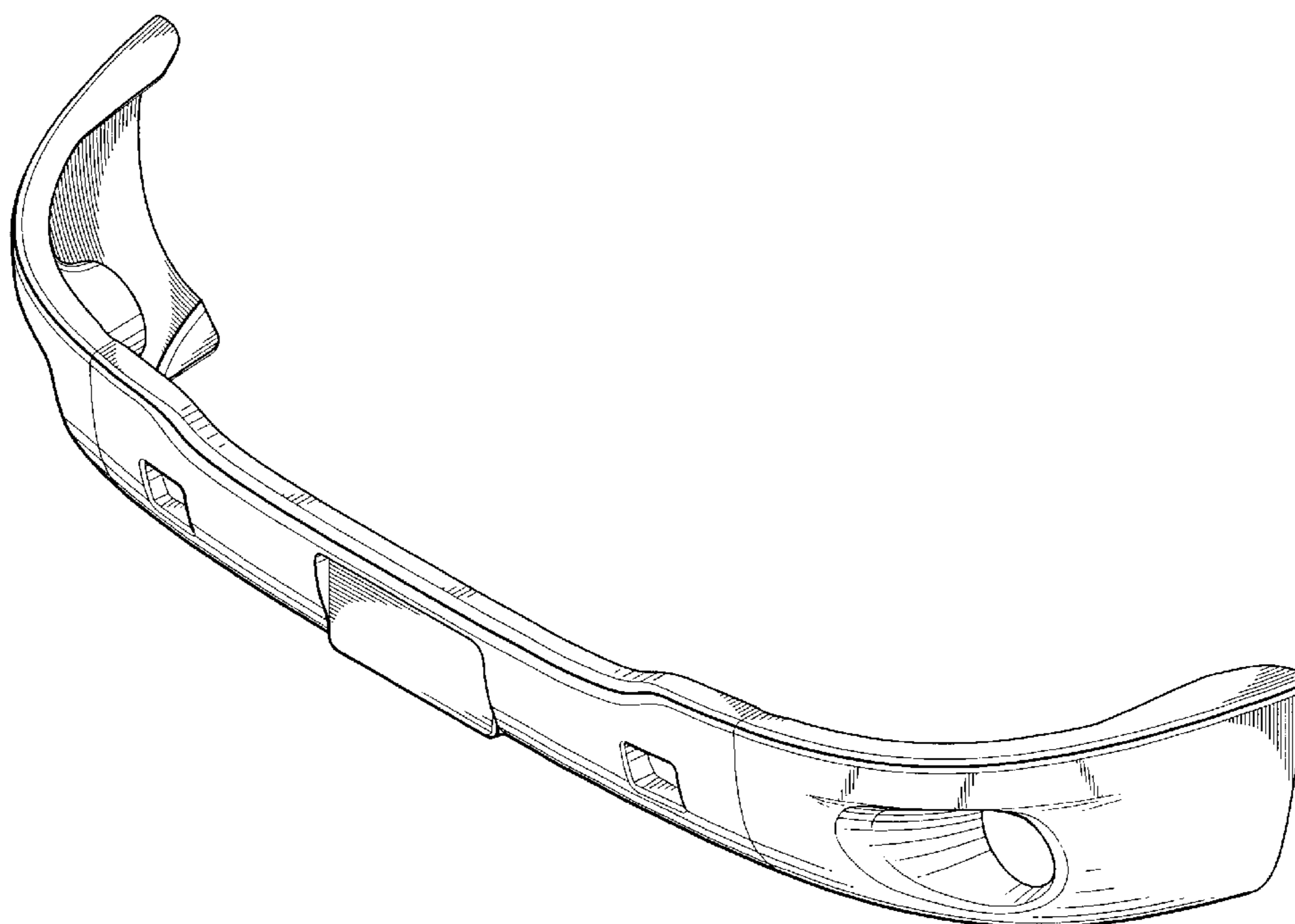
FIG. 11 is a top plan view of FIG. 8;

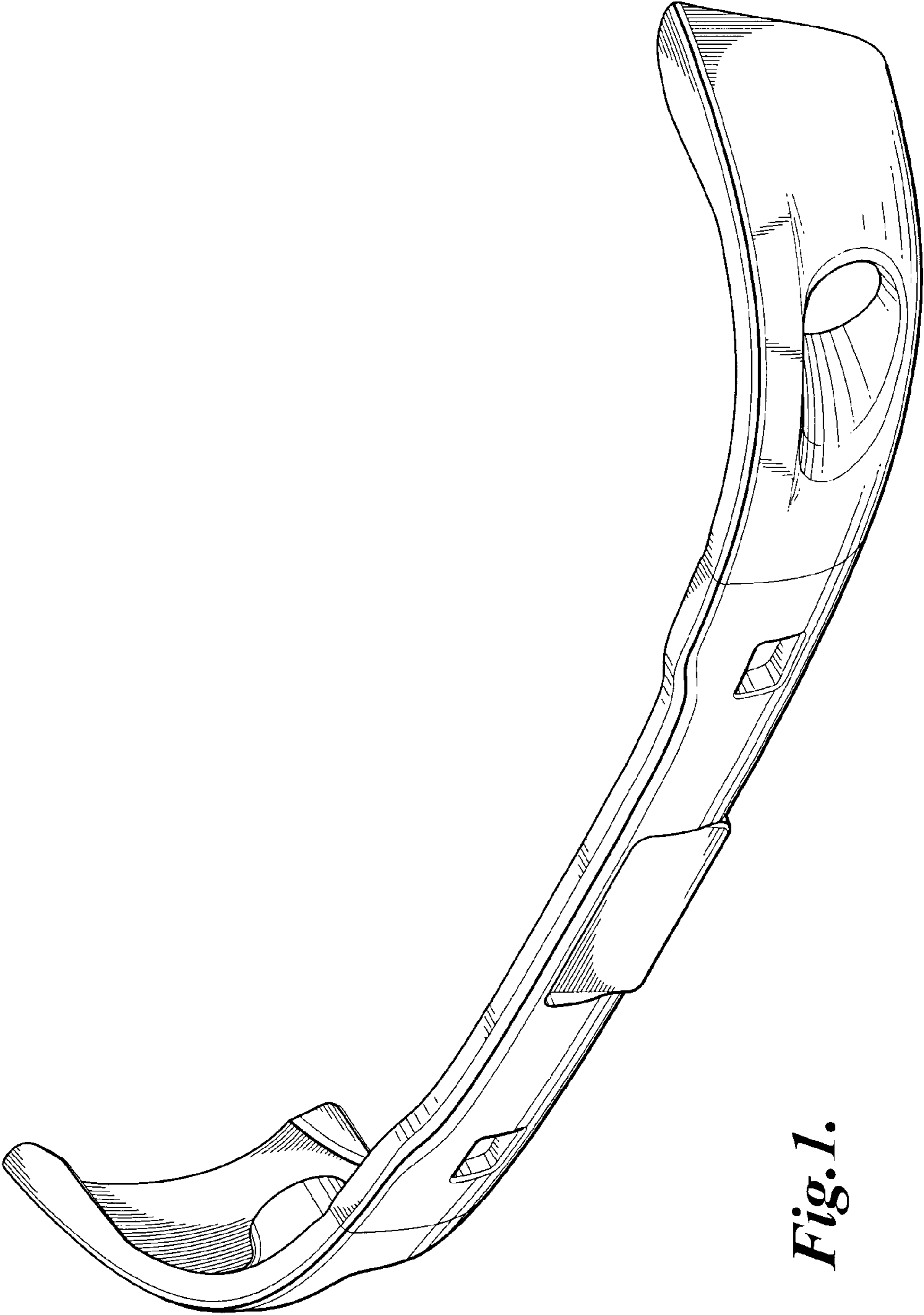
FIG. 12 is a bottom plan view of FIG. 8;

FIG. 13 is a left side elevational view of FIG. 8; and,

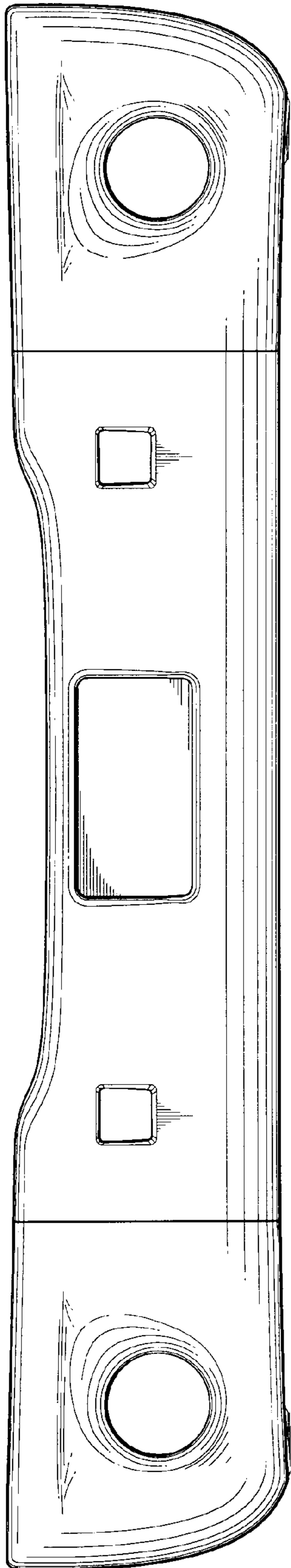
FIG. 14 is a right side elevational view of FIG. 8.

**1 Claim, 8 Drawing Sheets**

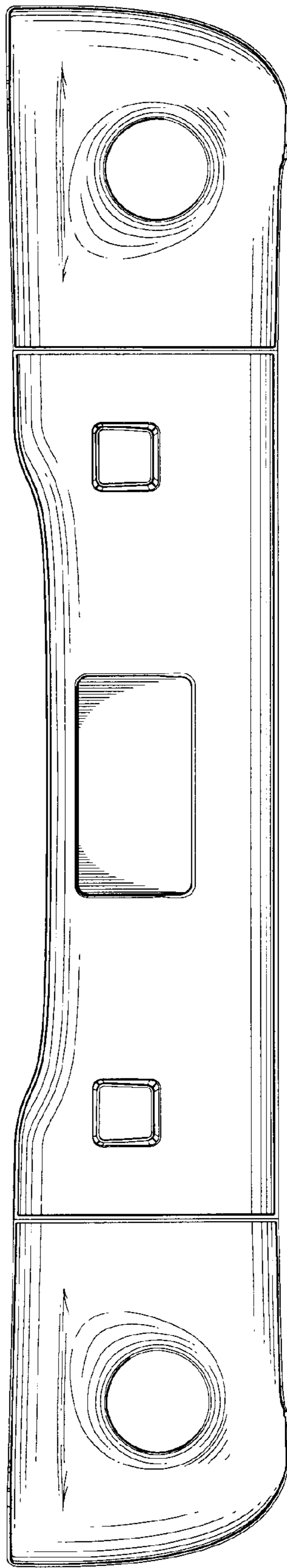




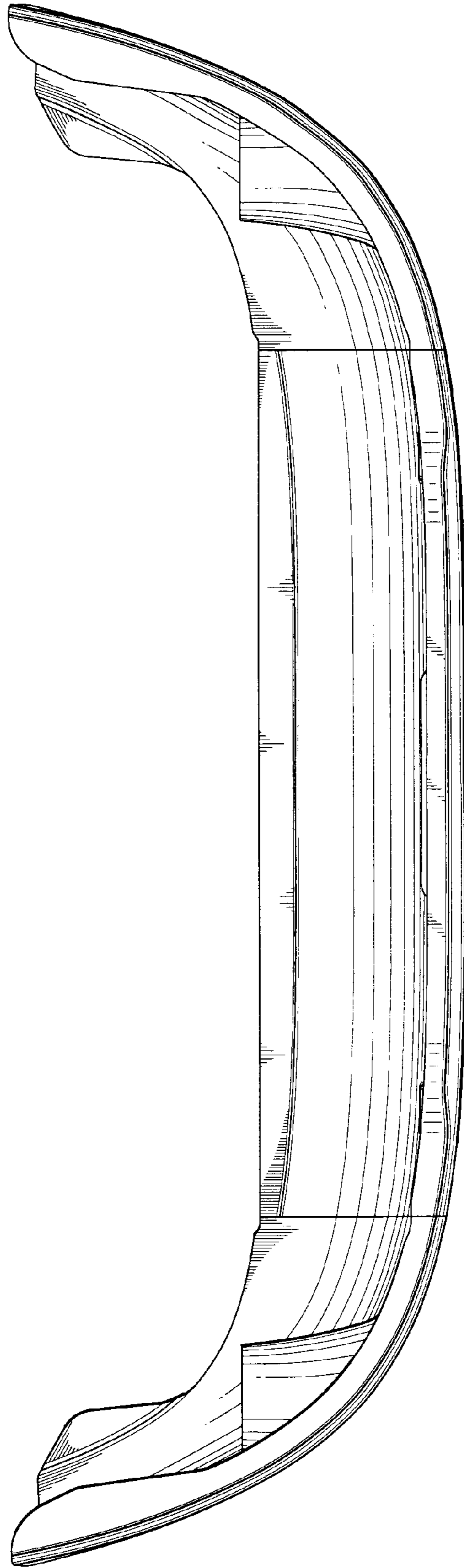
*Fig. 1.*



*Fig. 2.*

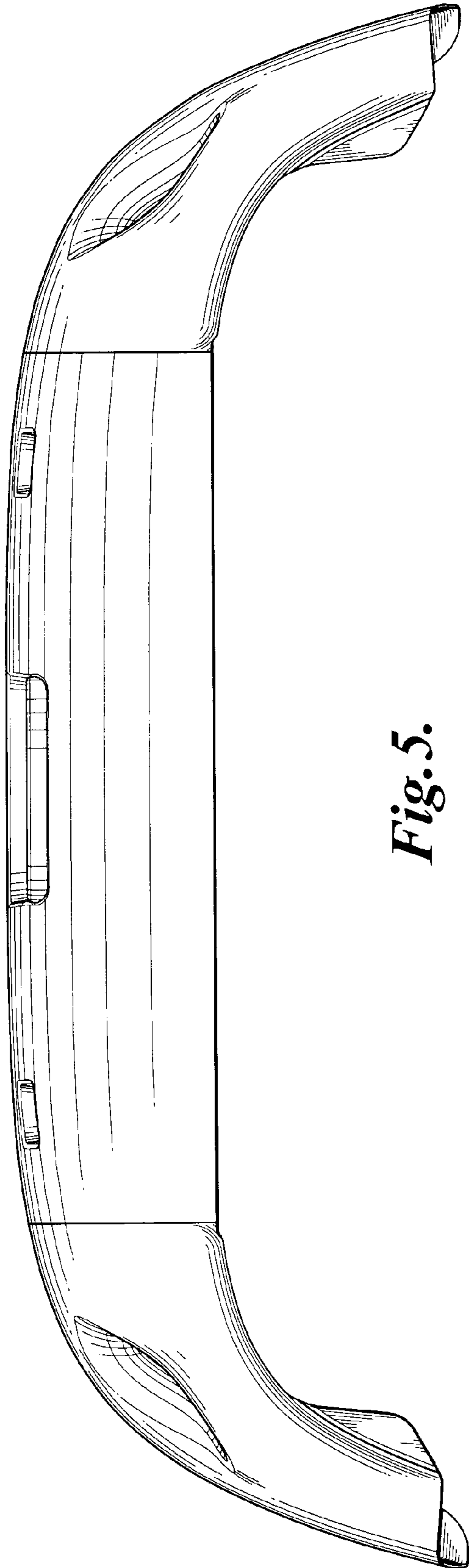


*Fig. 3.*

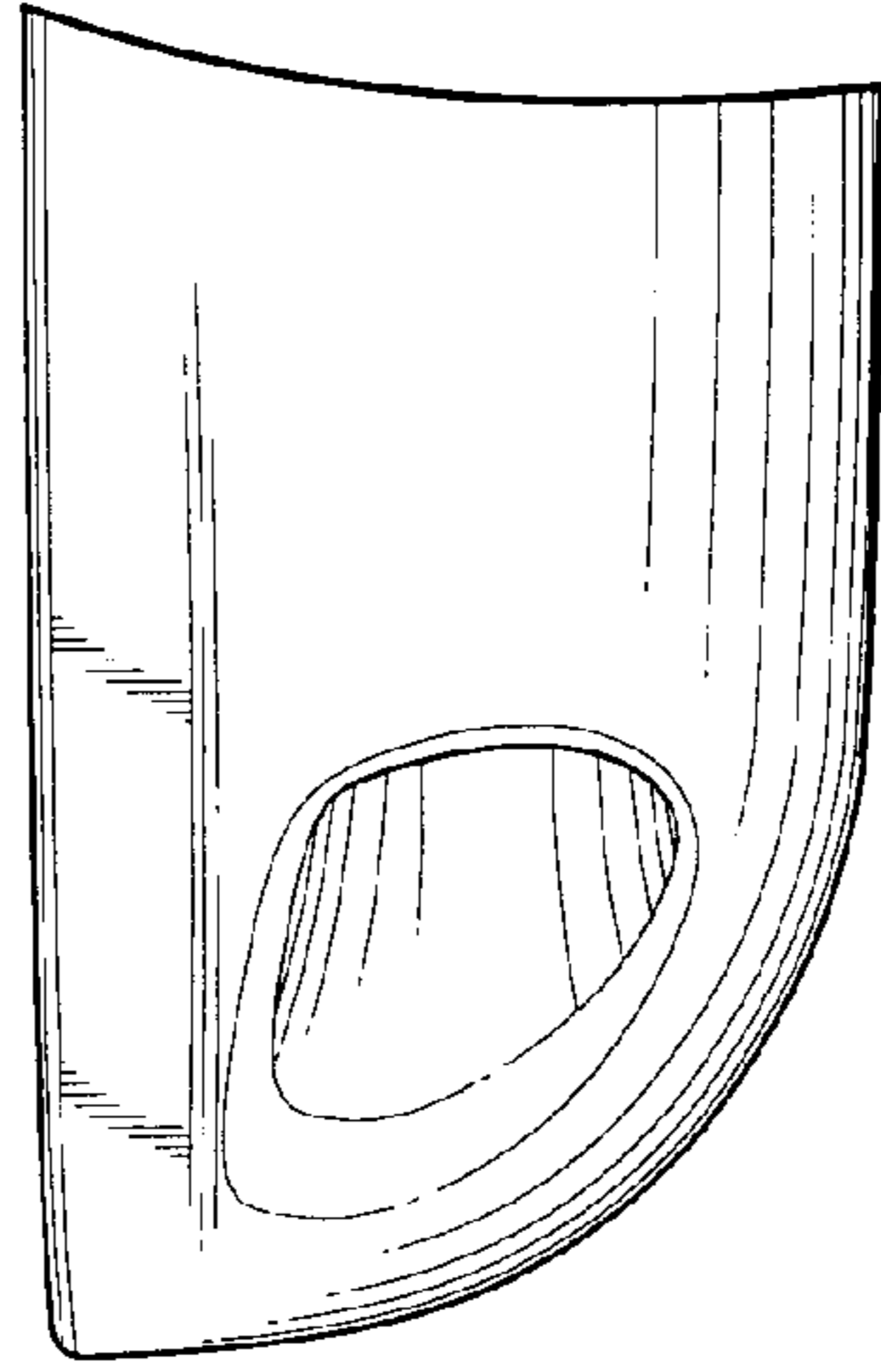


*Fig. 4.*

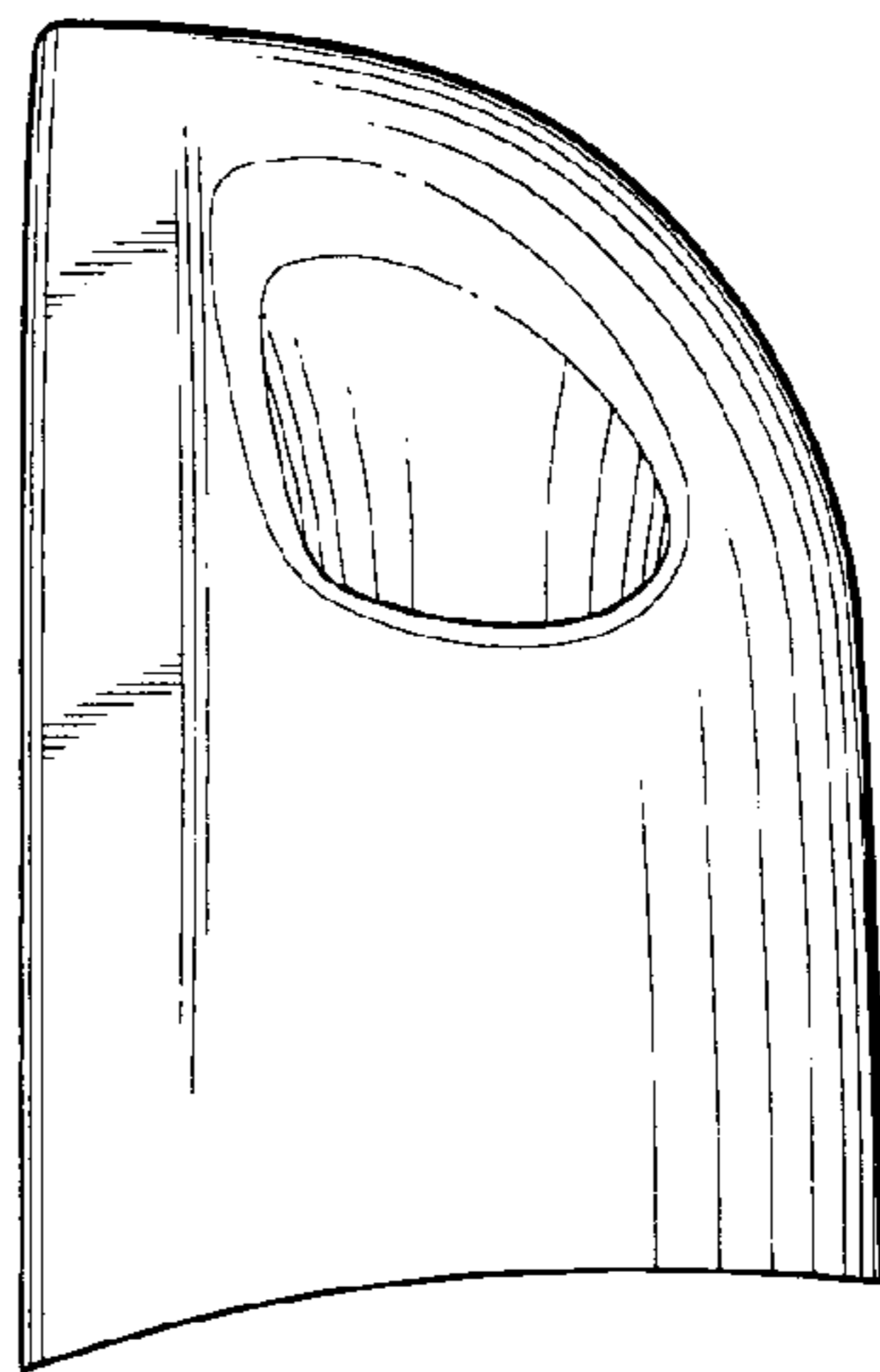




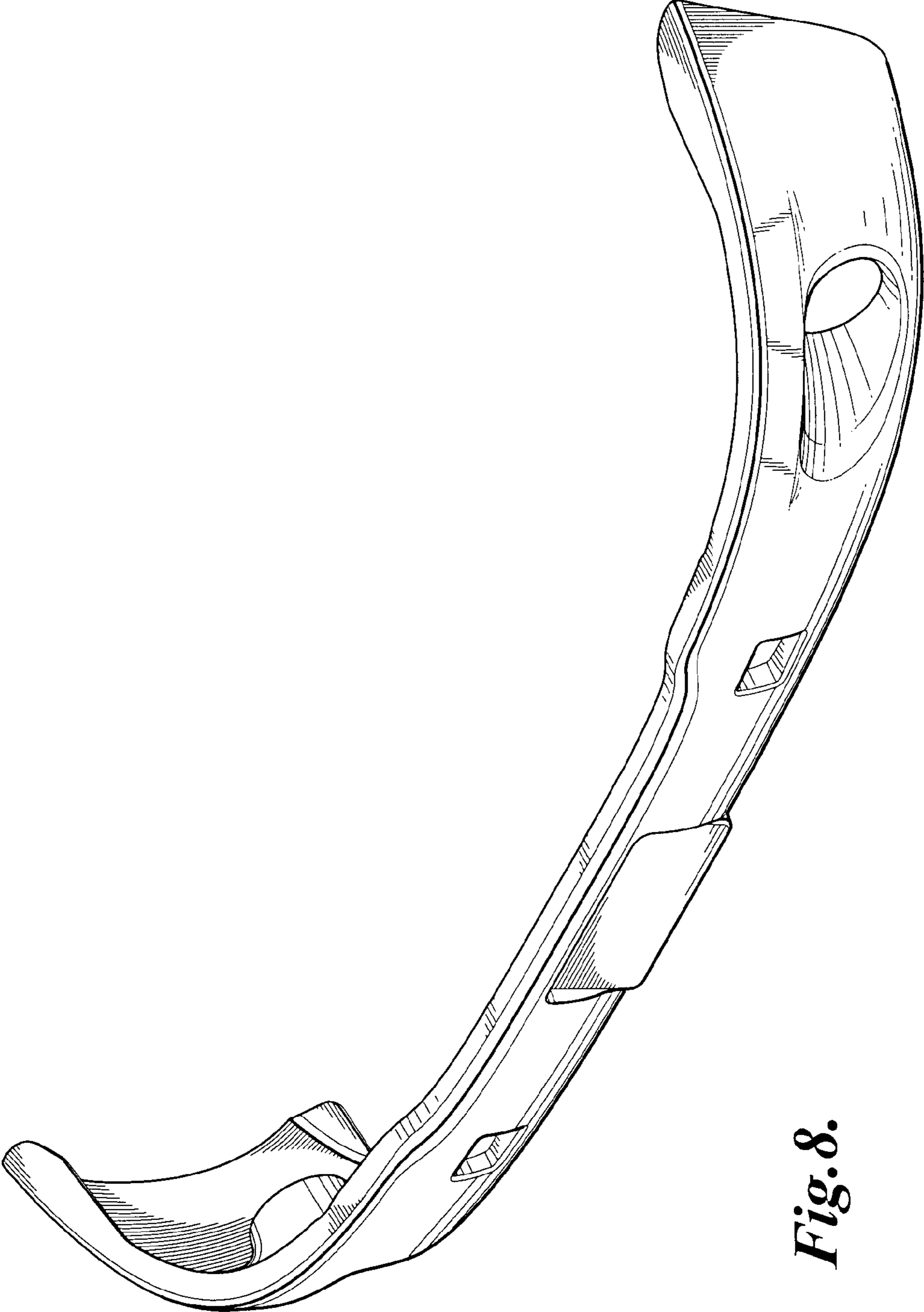
*Fig. 5.*



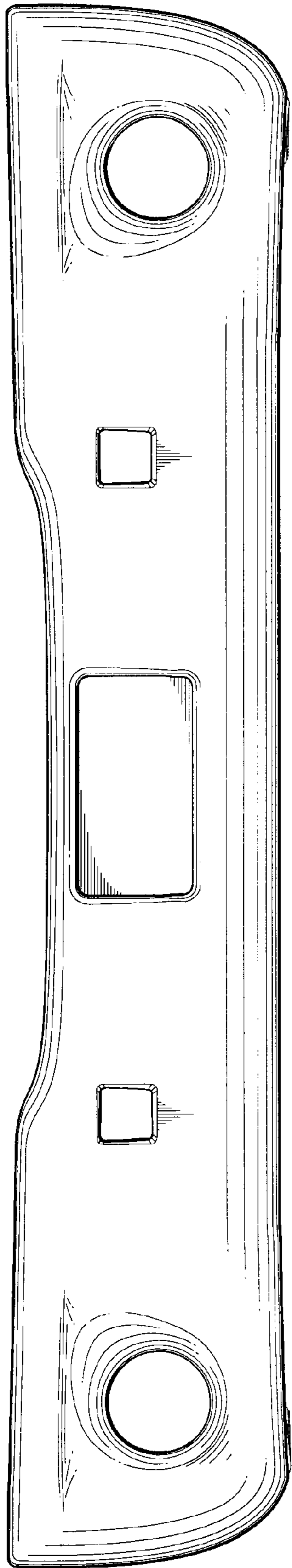
*Fig. 7.*



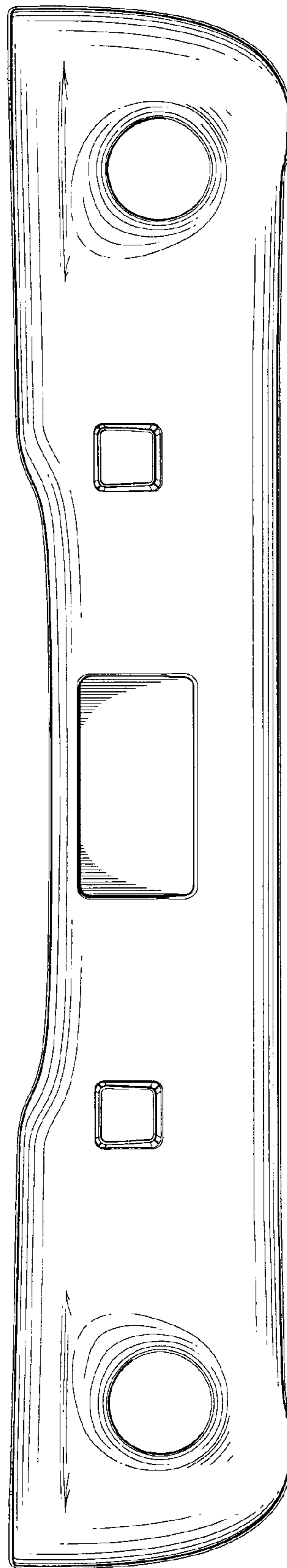
*Fig. 6.*



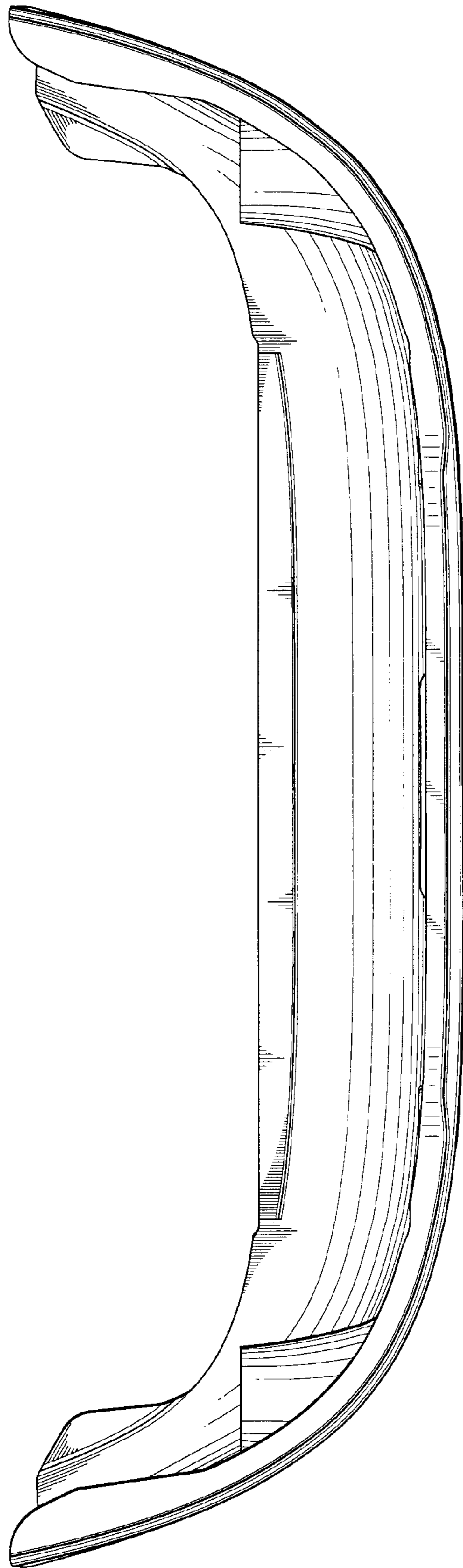
*Fig. 8.*



*Fig. 9.*

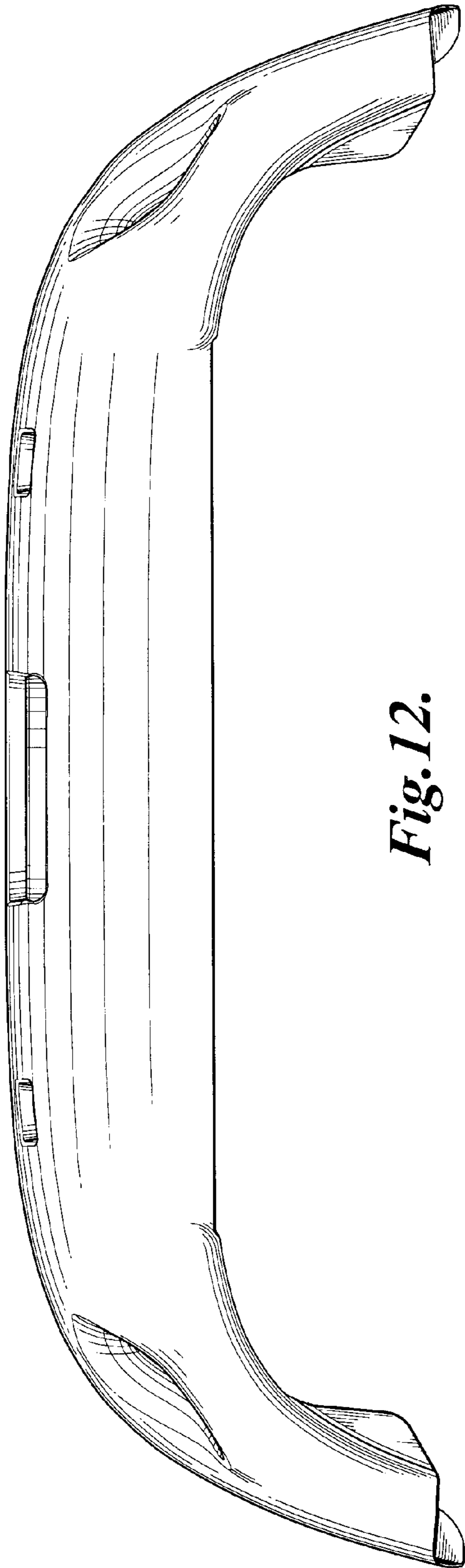


*Fig. 10.*

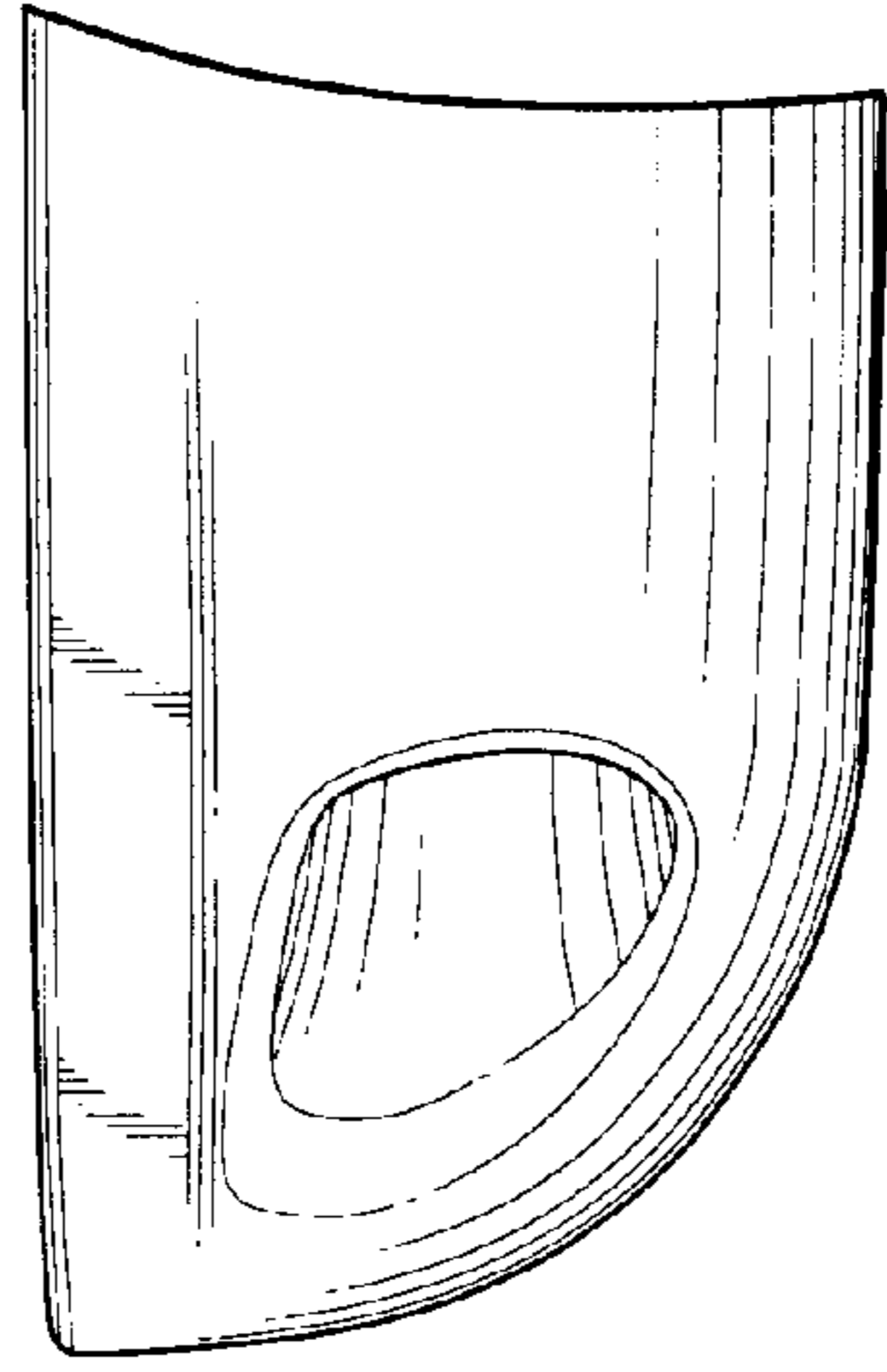


*Fig. 11.*

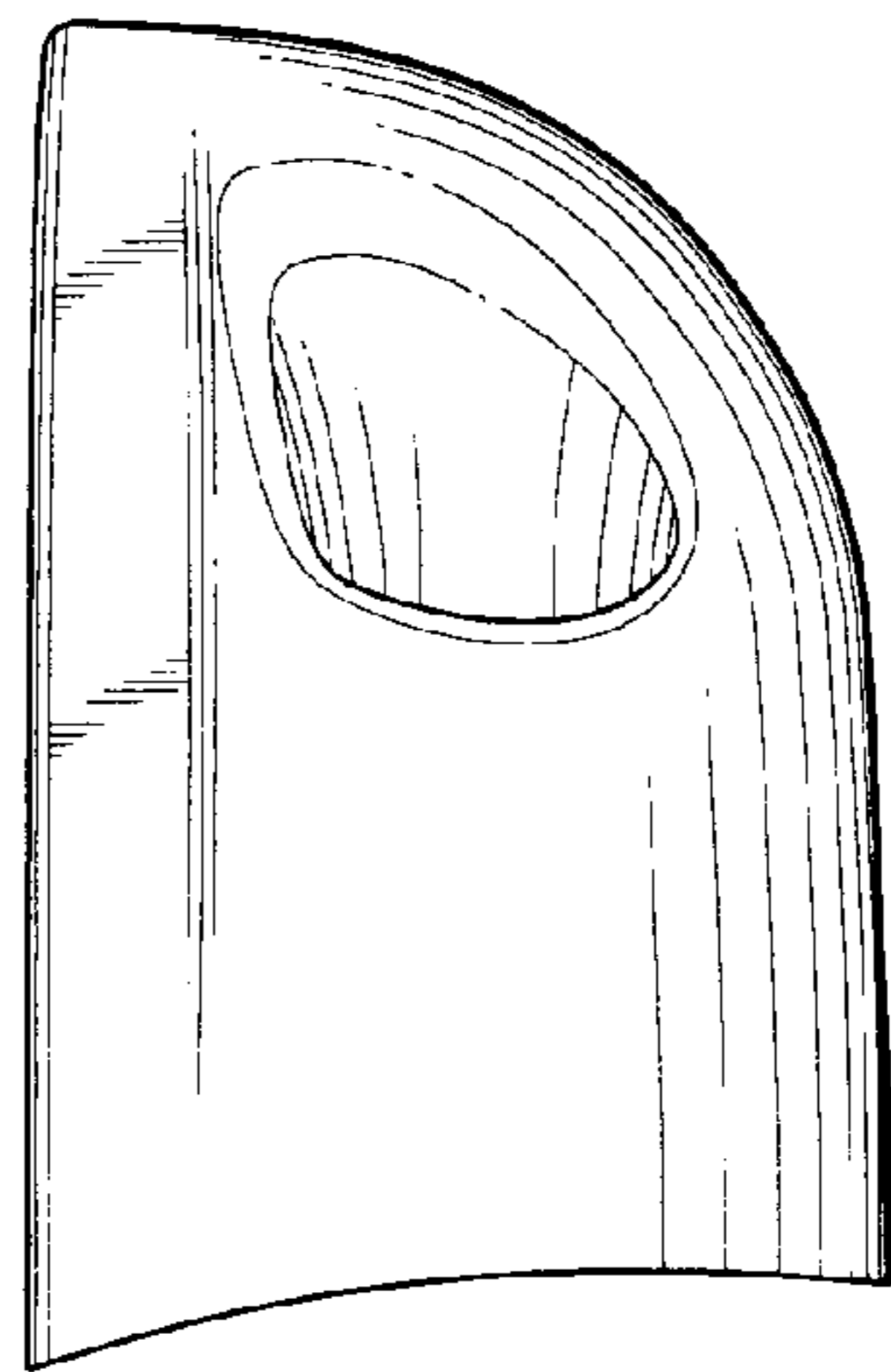




*Fig. 12.*



*Fig. 14.*



*Fig. 13.*

UNITED STATES PATENT AND TRADEMARK OFFICE  
**CERTIFICATE OF CORRECTION**

PATENT NO. : Des. 518,424 S  
APPLICATION NO. : 29/225509  
DATED : April 4, 2006  
INVENTOR(S) : G. Clark et al.

Page 1 of 1

It is certified that error appears in the above-identified patent and that said Letters Patent is hereby corrected as shown below:

On the Title Page:

Item (73) Assignee "**PACCAR Inc.,**" should read **--PACCAR Inc--**  
Pg. 1, col. 1

Signed and Sealed this

Seventeenth Day of October, 2006

A handwritten signature in black ink on a light gray dotted background. The signature reads "Jon W. Dudas" in a cursive style.

JON W. DUDAS

*Director of the United States Patent and Trademark Office*