



US00D518418S

(12) **United States Design Patent**
Hoffman

(10) **Patent No.:** **US D518,418 S**

(45) **Date of Patent:** **** Apr. 4, 2006**

(54) **AXLE SLIDER FOR A MOTORCYCLE**

(75) Inventor: **Harry Hoffman**, San Carlos, CA (US)

(73) Assignee: **Hoffman Metal Products Inc.**, San Carlos, CA (US)

(**) Term: **14 Years**

(21) Appl. No.: **29/217,632**

(22) Filed: **Nov. 17, 2004**

(51) **LOC (8) Cl.** **12-11**

(52) **U.S. Cl.** **D12/114**

(58) **Field of Classification Search** D12/110,
D12/117, 114, 126, 159, 160; D8/397, 399;
411/366.1, 403, 411, 427, 429; 474/116, 144;
280/288.4, 274, 275, 304.3, 6.16, 86.75;
301/110.5, 120, 122, 111.01–111.07; 74/607,
74/608

See application file for complete search history.

(56) **References Cited**

U.S. PATENT DOCUMENTS

444,517 A * 1/1891 Bock 301/122

D456,750 S * 5/2002 McWilliams et al. D12/114
2002/0180256 A1 * 12/2002 Reich 301/111.01

* cited by examiner

Primary Examiner—Alan P. Douglas

Assistant Examiner—Linda Brooks

(74) *Attorney, Agent, or Firm*—Perkins Coie LLP

(57) **CLAIM**

I claim the ornamental design for an axle slider for a motorcycle, as shown and described.

DESCRIPTION

FIG. 1 is a perspective view of an axle slider for a motorcycle;

FIG. 2 is an enlarged elevational view at an angle thereof;

FIG. 3 is an enlarged front elevational view thereof; and,

FIG. 4 is an enlarged side elevational view thereof.

The broken line showing of the environment is for illustration purposes only and forms no part of the claimed design.

The broken lines which define the boundaries of the claimed design form no part thereof.

1 Claim, 4 Drawing Sheets

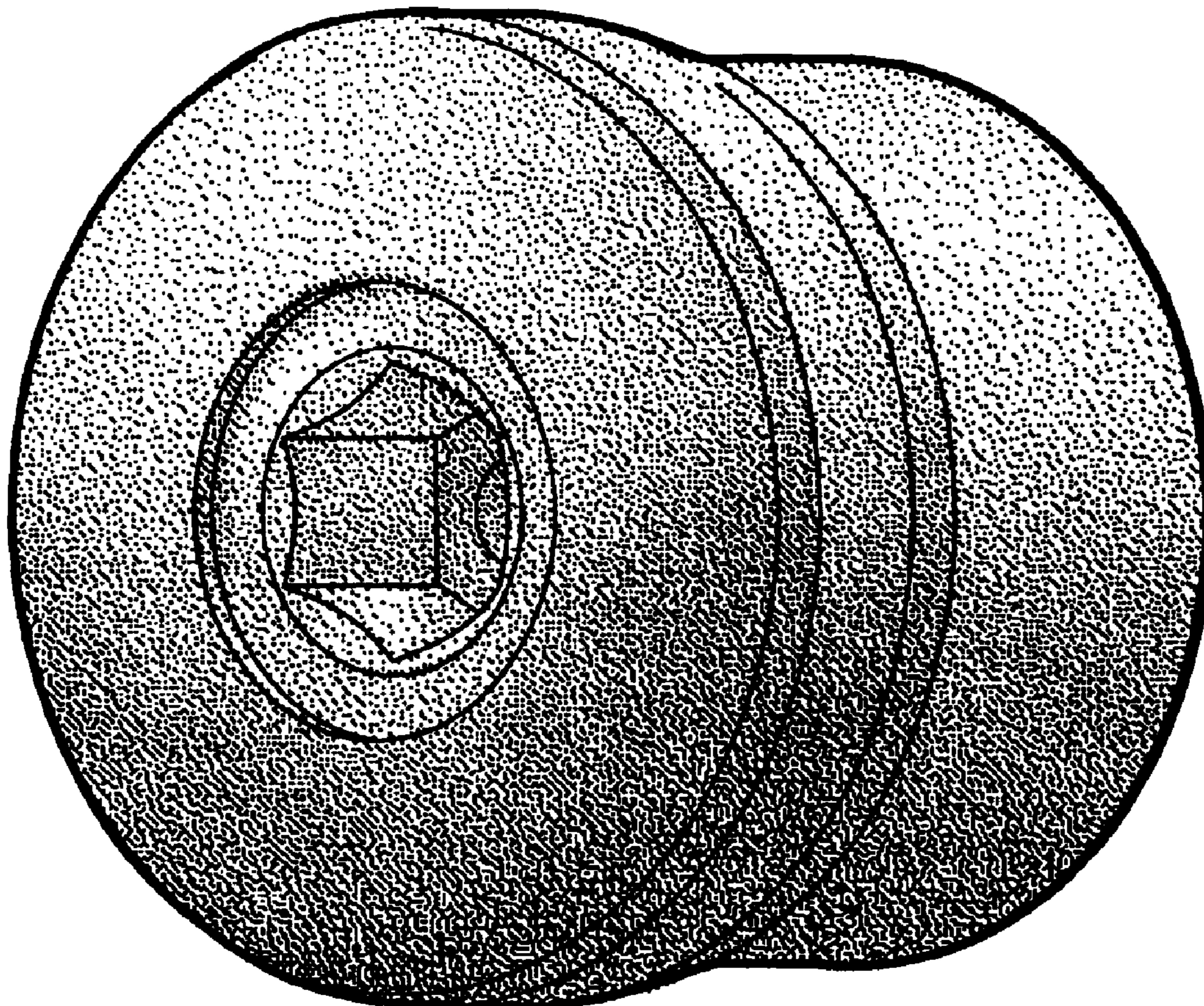

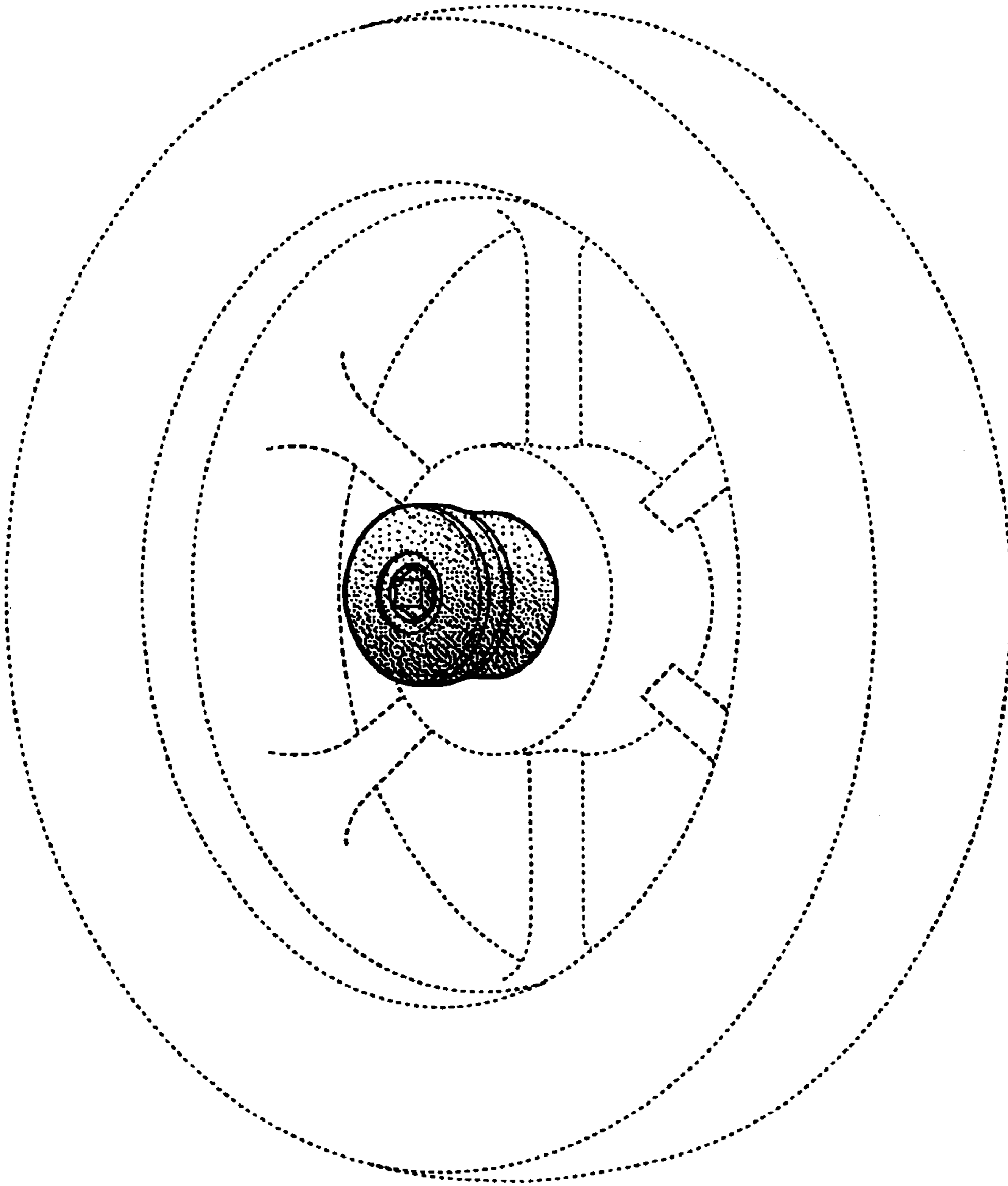

Fig. 1

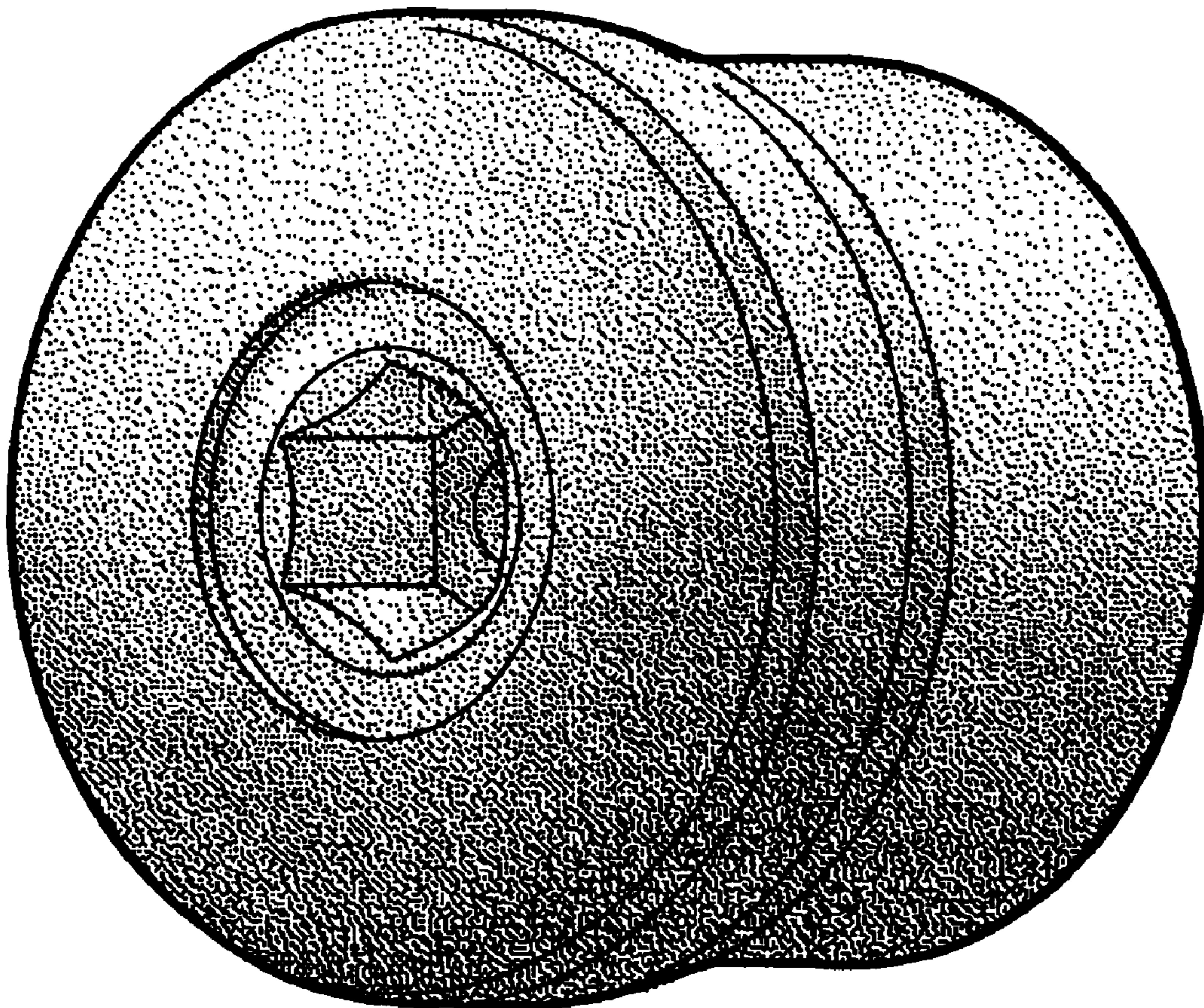

Fig. 2

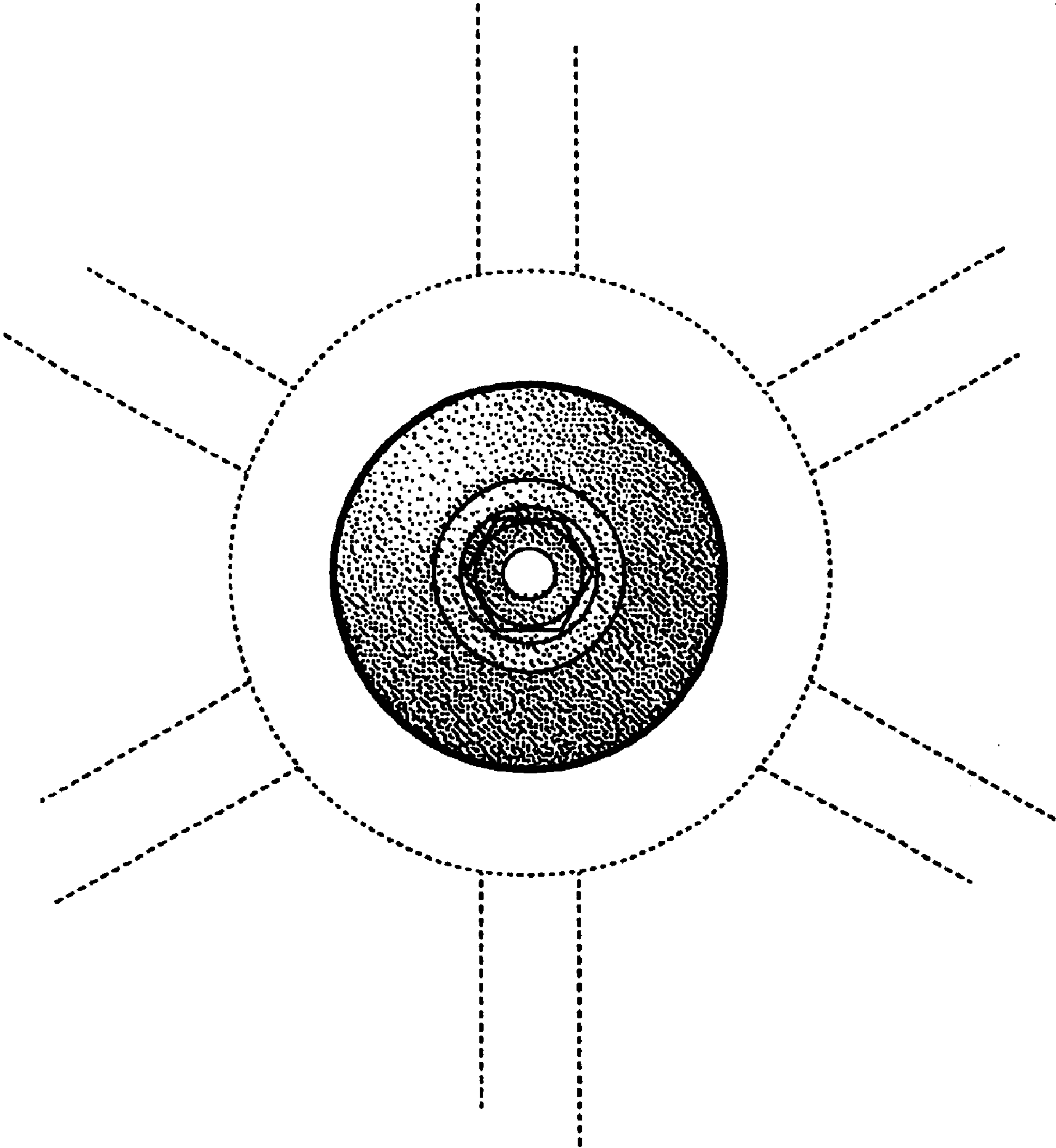

Fig. 3

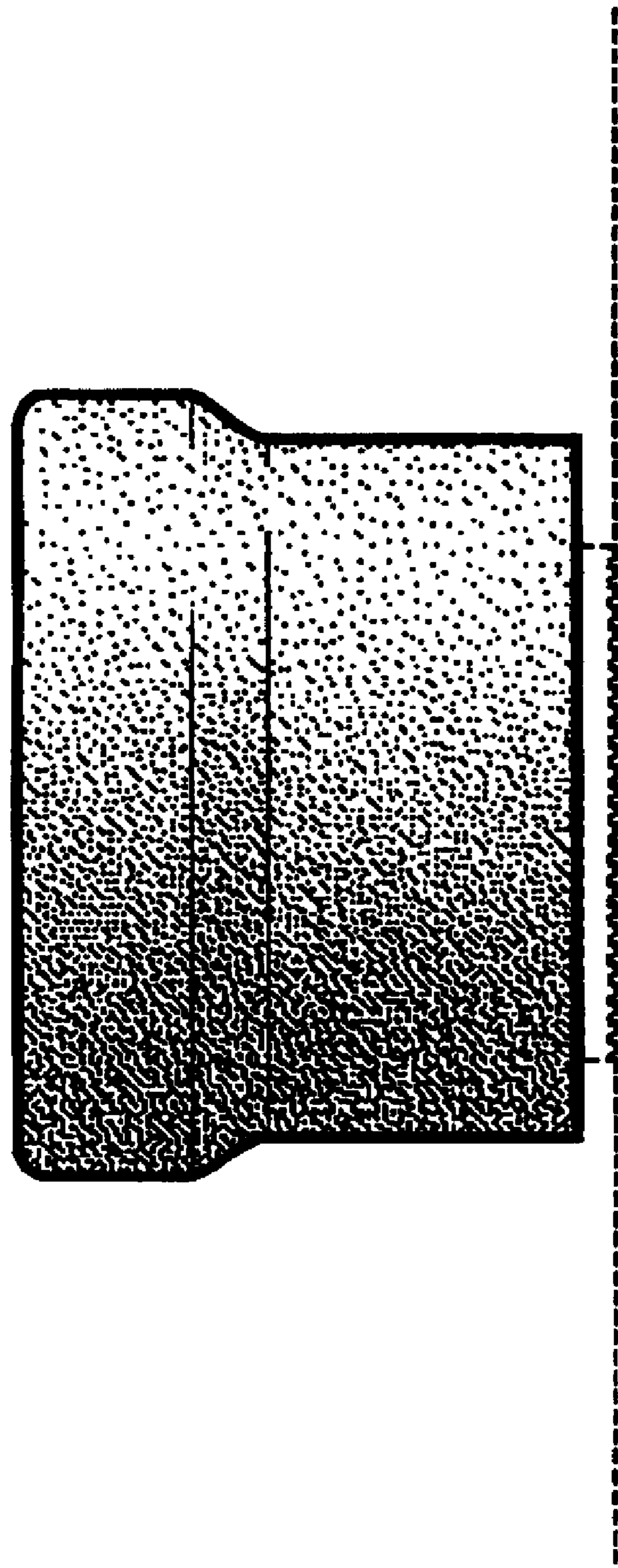

Fig. 4