



US00D517997S

(12) **United States Design Patent** (10) **Patent No.:** **US D517,997 S**  
**Disbennett et al.** (45) **Date of Patent:** **\*\* Mar. 28, 2006**

(54) **FUSED DISTRIBUTION BLOCK**

(75) Inventors: **Scott Disbennett**, Lake Mary, FL (US);  
**Edward T. Robertson**, Port Orange, FL (US)

(73) Assignee: **Metra Electronics Corporation**, Holly Hill, FL (US)

(\*\*) Term: **14 Years**

(21) Appl. No.: **29/222,513**

(22) Filed: **Feb. 2, 2005**

(51) **LOC (8) Cl.** ..... **13-03**

(52) **U.S. Cl.** ..... **D13/161**

(58) **Field of Classification Search** ..... D13/160,  
D13/161, 178; 337/181, 186, 196, 199, 205,  
337/213; 361/600, 626, 642, 646, 833, 834,  
361/809, 835; 439/76.12, 621, 622, 698,  
439/830, 831, 832

See application file for complete search history.

(56) **References Cited**

**U.S. PATENT DOCUMENTS**

5,167,541	A	*	12/1992	Alves et al.	439/622
5,618,209	A		4/1997	Lin et al.	439/621
D381,010	S		7/1997	Ansley	D13/178
5,648,749	A		7/1997	Lin et al.	337/205
D406,111	S	*	2/1999	Awbrey	D13/178
D406,569	S	*	3/1999	Awbrey et al.	D13/178
6,004,159	A		12/1999	Liang	439/621
6,162,097	A		12/2000	Liang	439/621
D442,148	S	*	5/2001	Renne et al.	D13/178
6,309,253	B1	*	10/2001	Tsai	439/621
6,753,754	B1	*	6/2004	Black et al.	337/215

**OTHER PUBLICATIONS**

2003 Tsunami Premium Installation Accessories Catalog, pp. cover, 16–24, published Feb. 2003.

2004 Tsunami Premium Installation Accessories Catalog, pp. cover, 18–28, published Feb. 2004.

2003 Raptor Installation Accessories Catalog, pp. cover, 8–11, published Feb. 2003.

\* cited by examiner

*Primary Examiner*—Stella Reid  
*Assistant Examiner*—Selina Sikder

(74) *Attorney, Agent, or Firm*—Fitzpatrick, Cella, Harper & Scinto

(57) **CLAIM**

We claim the ornamental design for a fused distribution block, as shown and described.

**DESCRIPTION**

FIG. 1 is a left-front perspective view of a first embodiment of a fused distribution block showing our new design;

FIG. 2 is a front elevation of FIG. 1;

FIG. 3 is a rear elevation of FIG. 1;

FIG. 4 is a left side elevation of FIG. 1;

FIG. 5 is a right side elevation of FIG. 1;

FIG. 6 is a top plan view of FIG. 1;

FIG. 7 is a bottom plan view of FIG. 1;

FIG. 8 is a left-front perspective view of FIG. 1 showing the hinged access cover open;

FIG. 9 is a left-front perspective view of a second embodiment of a fused distribution block showing our new design;

FIG. 10 is a front elevation of FIG. 9;

FIG. 11 is a rear elevation of FIG. 9;

FIG. 12 is a left side elevation of FIG. 9;

FIG. 13 is a right side elevation of FIG. 9;

FIG. 14 is a top plan view of FIG. 9;

FIG. 15 is a bottom plan view of FIG. 9;

FIG. 16 is a left-front perspective view of FIG. 9 showing the hinged access cover open;

FIG. 17 is a perspective view of a third embodiment of a fused distribution block showing our new design;

FIG. 18 is a front elevation of FIG. 17;

FIG. 19 is a rear elevation of FIG. 17;

FIG. 20 is a left side elevation of FIG. 17;

FIG. 21 is a right side elevation of FIG. 17;

FIG. 22 is a top plan view of FIG. 17;

FIG. 23 is a bottom plan view of FIG. 17;

FIG. 24 is a left-front perspective view of FIG. 17 showing the hinged access cover open;

FIG. 25 is a left-front perspective view of a fourth embodiment of a fused distribution block showing our new design;

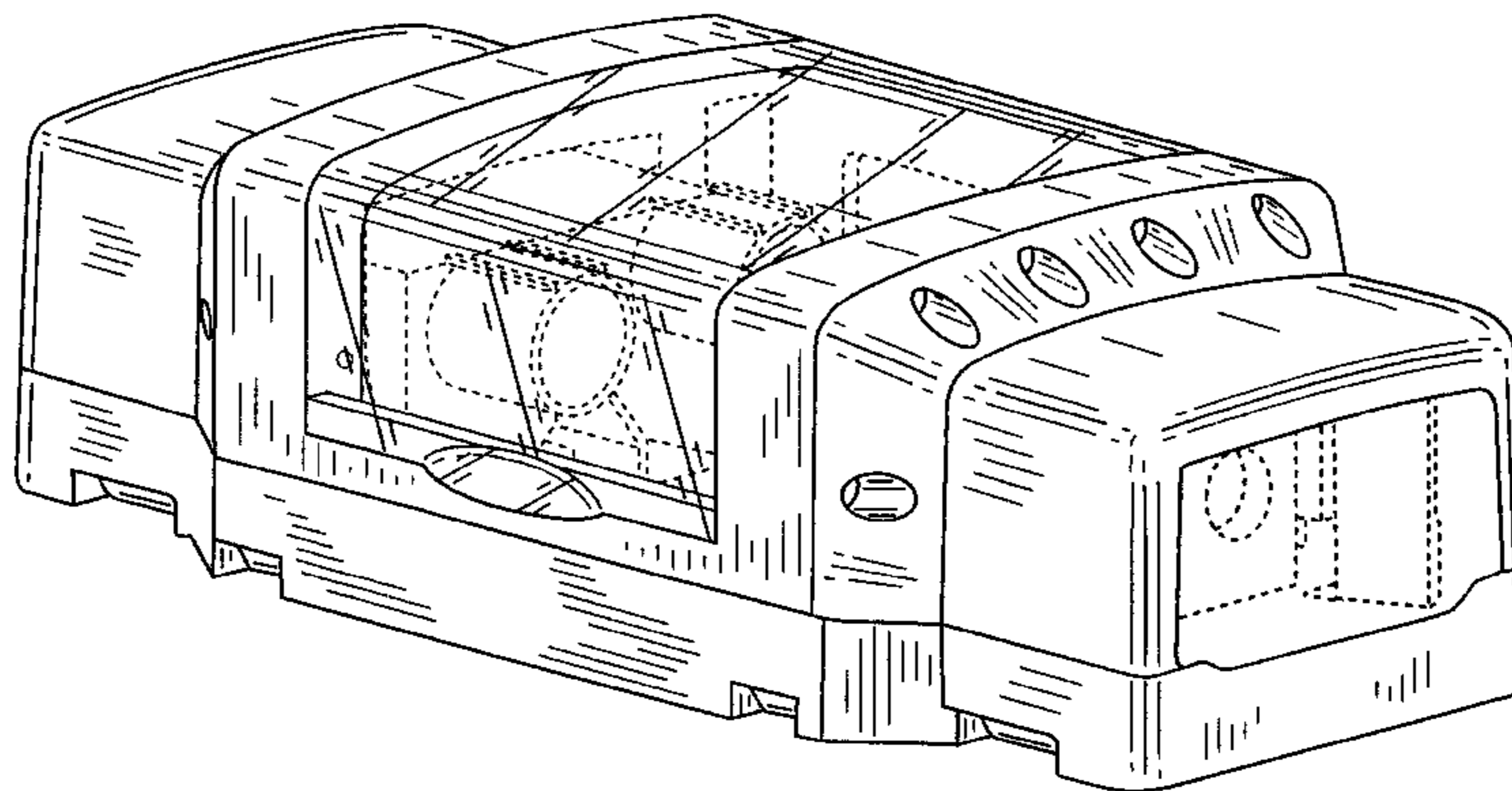
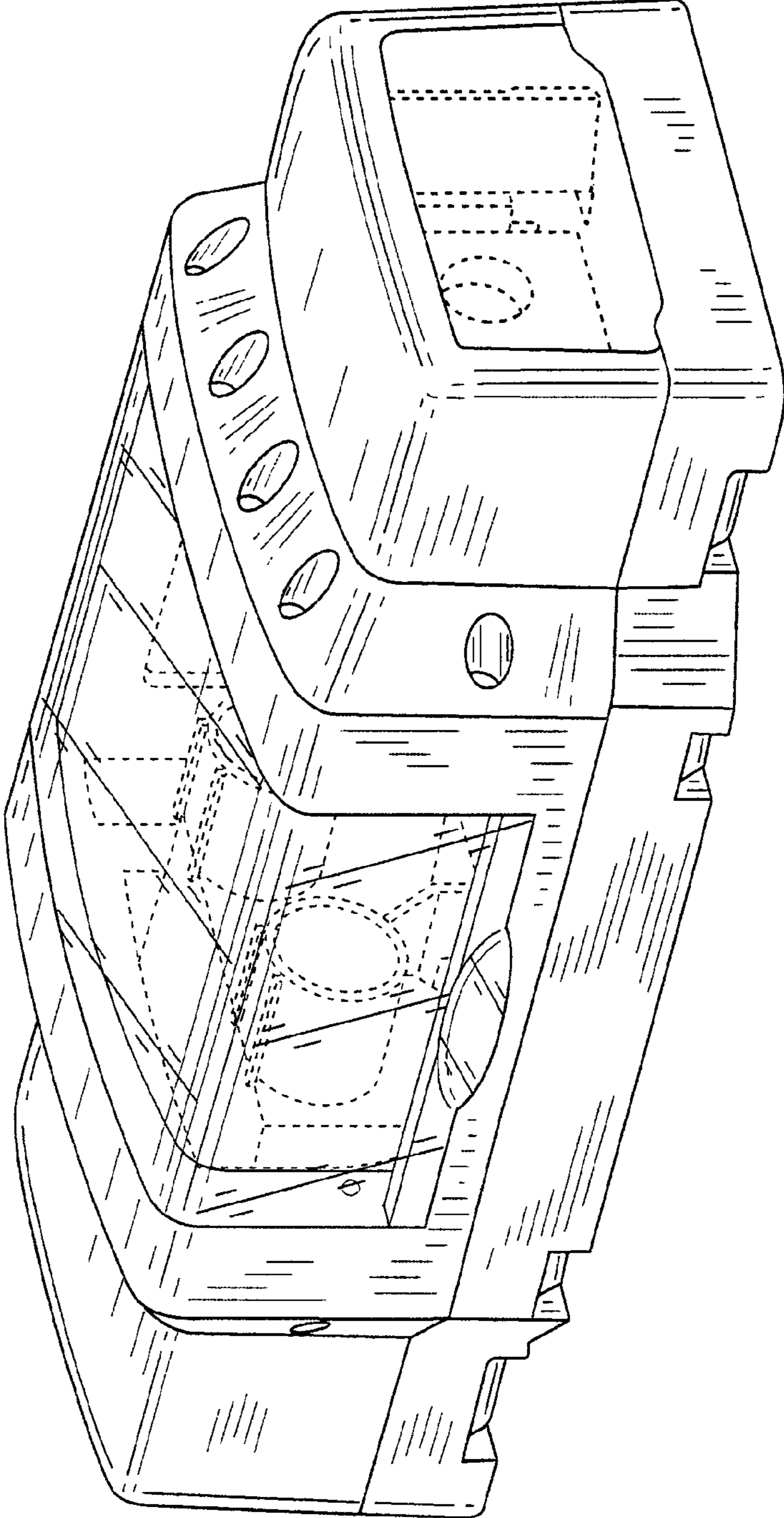


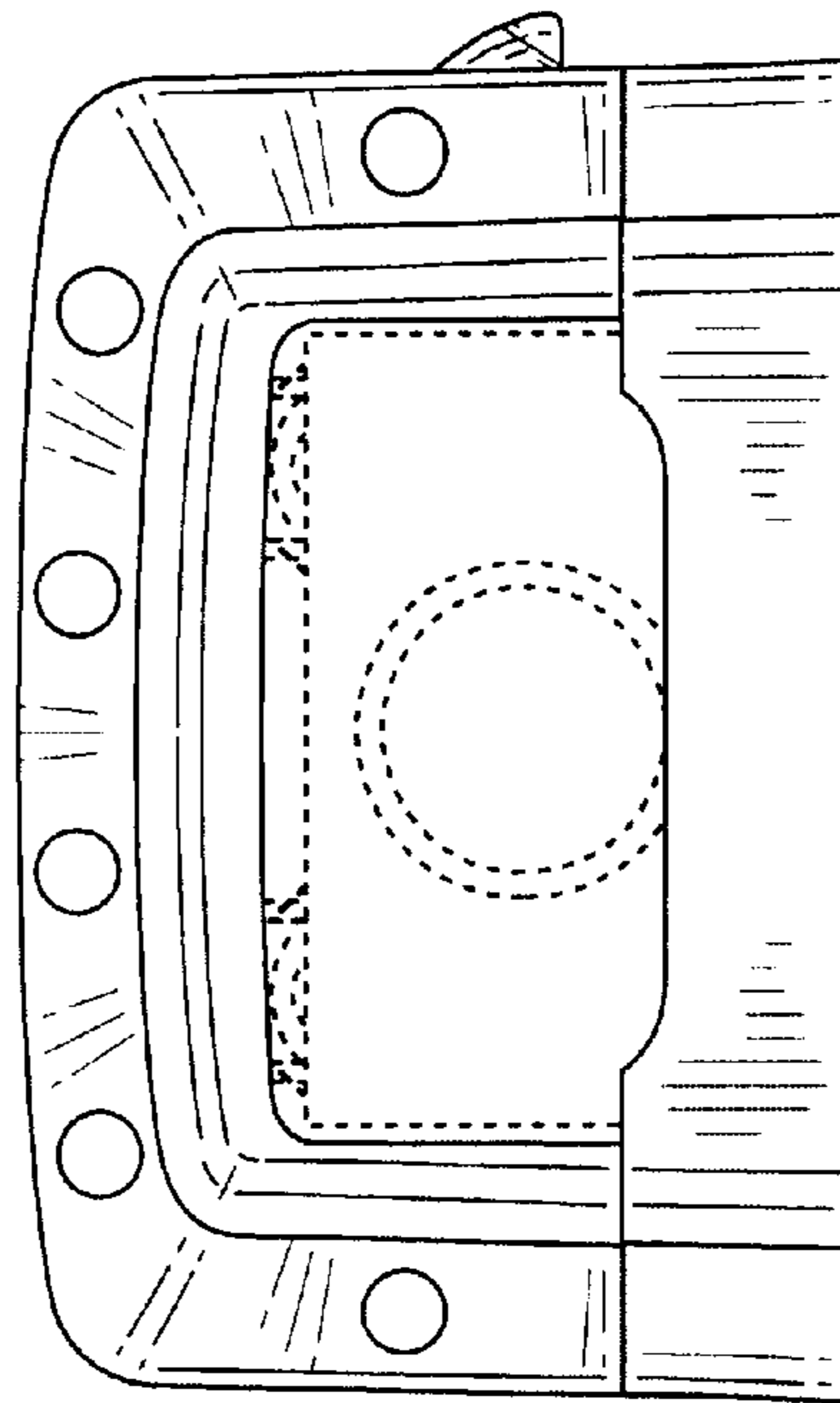
FIG. 26 is a front elevation of FIG. 25;  
FIG. 27 is a rear elevation of FIG. 25;  
FIG. 28 is a left side elevation of FIG. 25;  
FIG. 29 is a right side elevation of FIG. 25;  
FIG. 30 is a top plan view of FIG. 25;  
FIG. 31 is a bottom plan view of FIG. 25;  
FIG. 32 is a left-front perspective view of FIG. 25 showing the hinged access cover open;  
FIG. 33 is a left-front perspective view of a fifth embodiment of a fused distribution block showing our new design;  
FIG. 34 is a front elevation of FIG. 33;

FIG. 35 is a rear elevation of FIG. 33;  
FIG. 36 is a left side elevation of FIG. 33;  
FIG. 37 is a right side elevation of FIG. 33;  
FIG. 38 is a top plan view of FIG. 33;  
FIG. 39 is a bottom plan view of FIG. 33; and,  
FIG. 40 is a left-front perspective view of FIG. 33 showing the hinged access cover open.  
The broken line showing of the environment is for illustrative purpose only and forms no part of the claimed design.

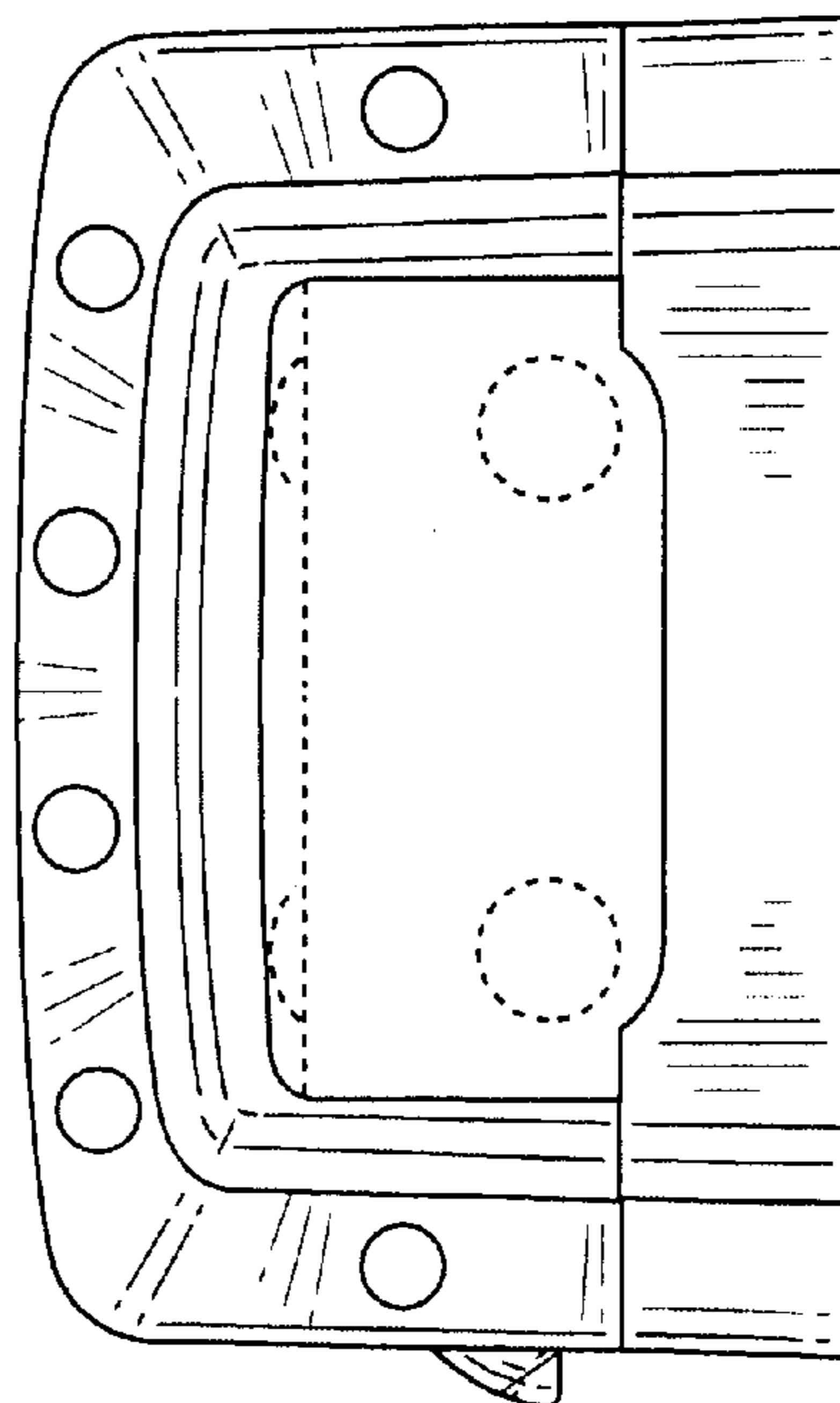
**1 Claim, 30 Drawing Sheets**



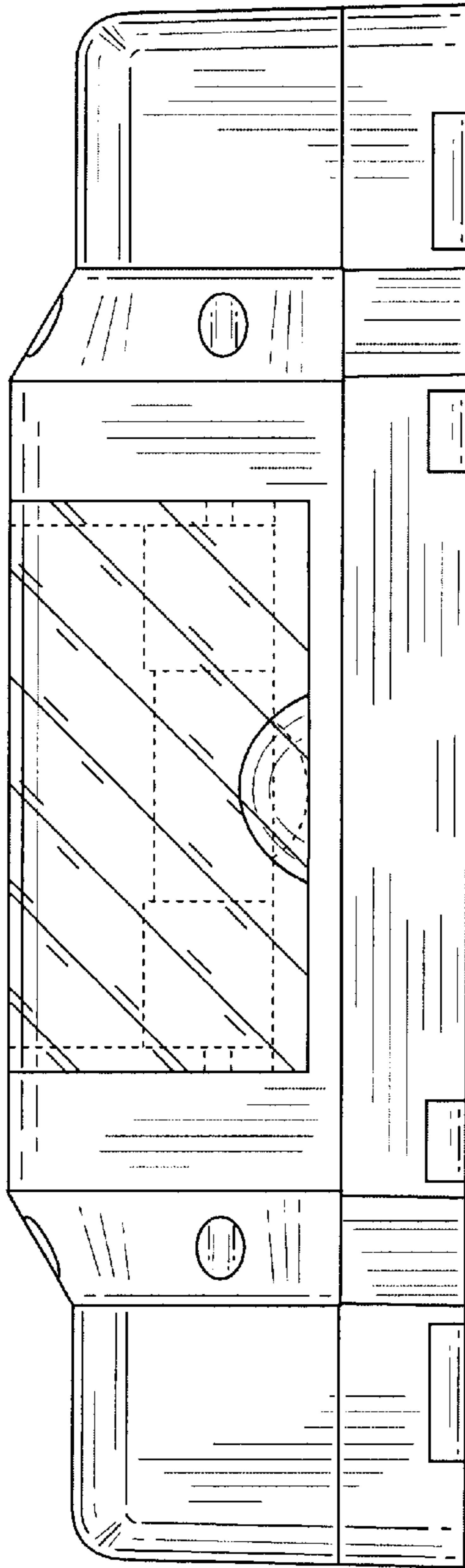
**FIG. 1**



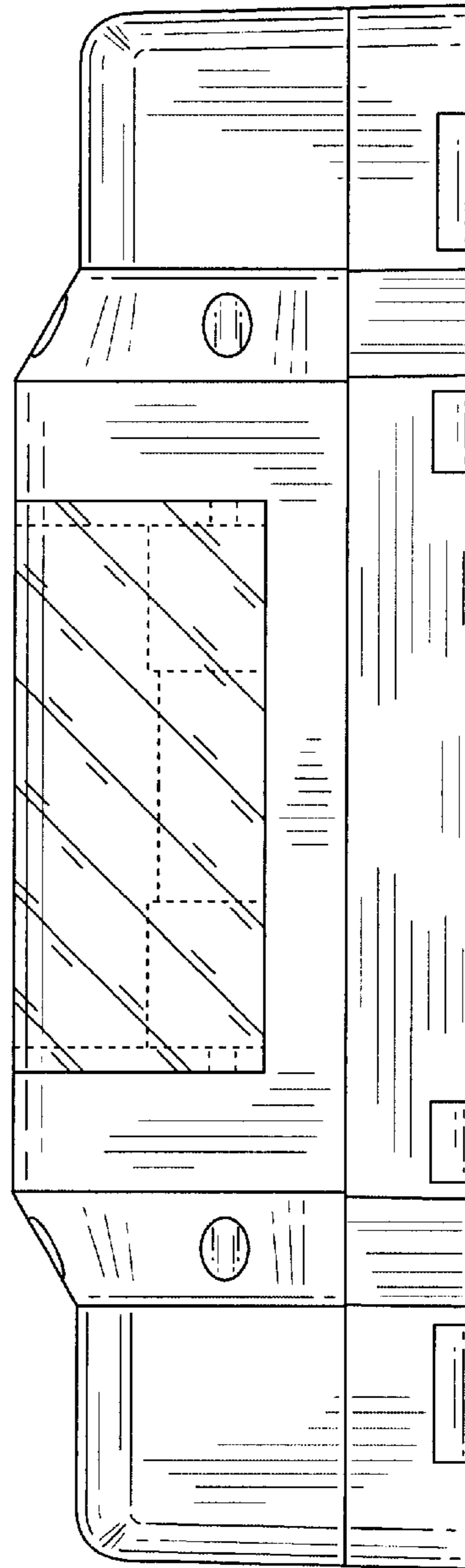
**FIG. 3**



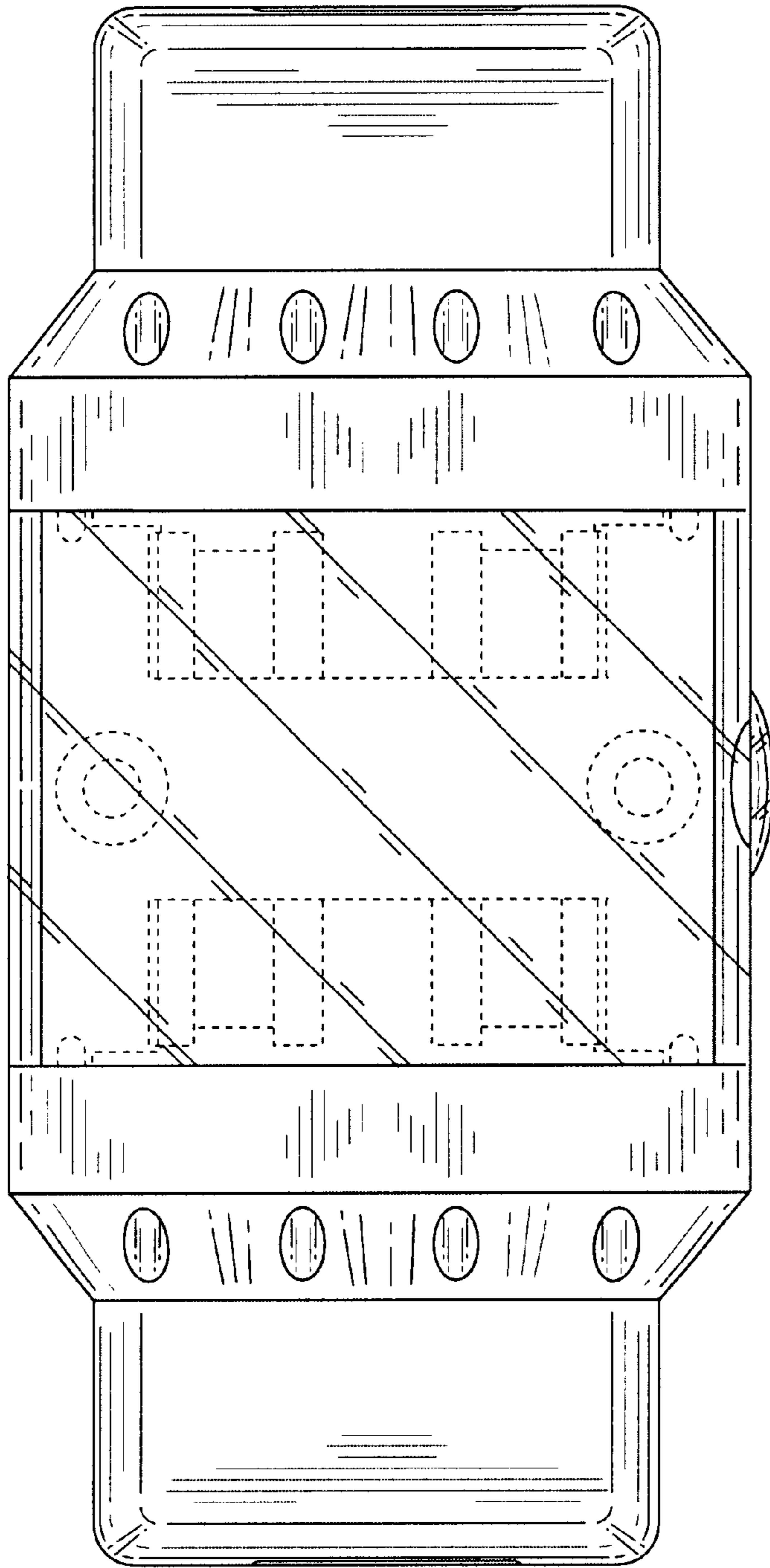
**FIG. 2**



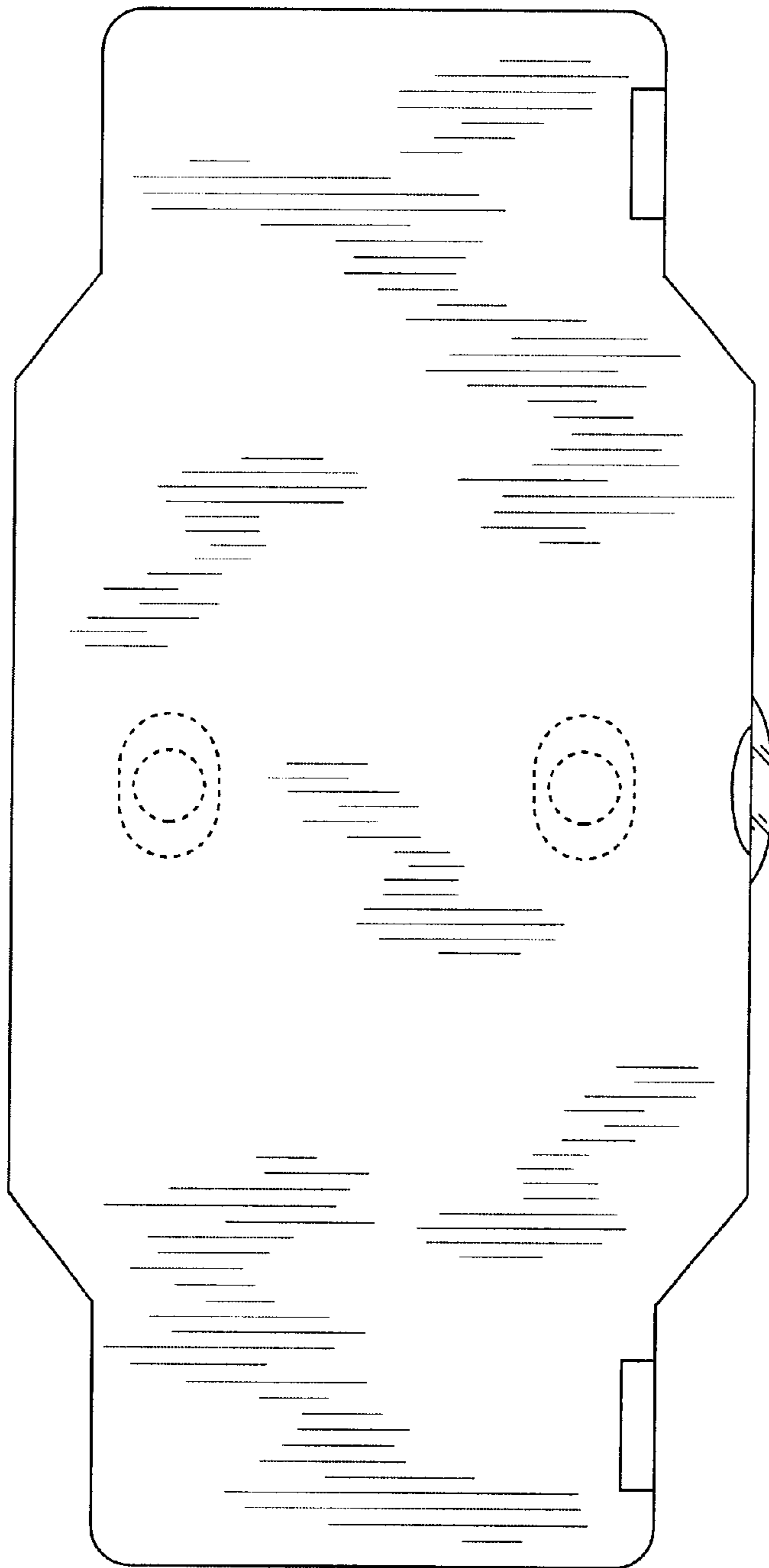
**FIG. 4**



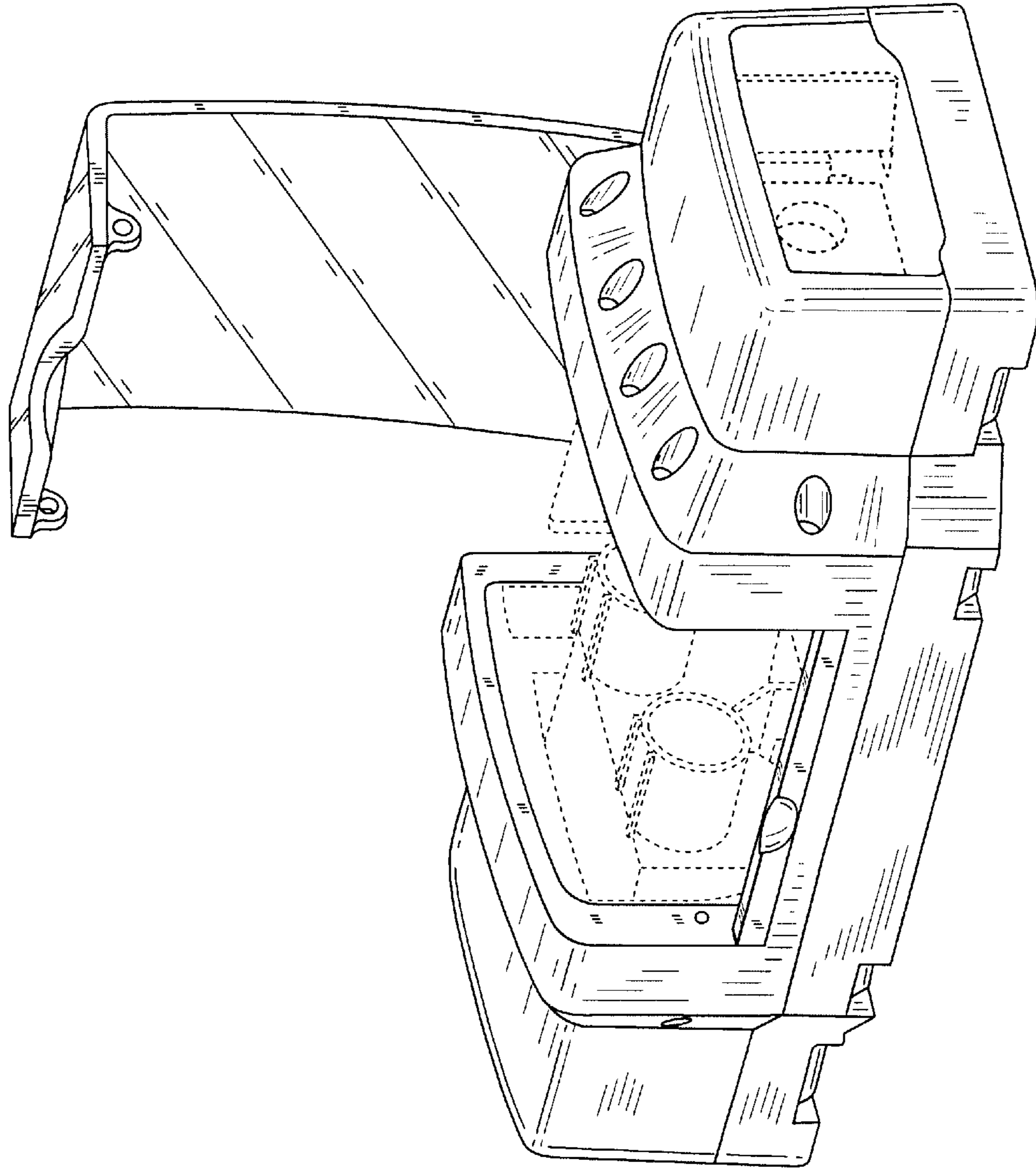
**FIG. 5**



**FIG. 6**

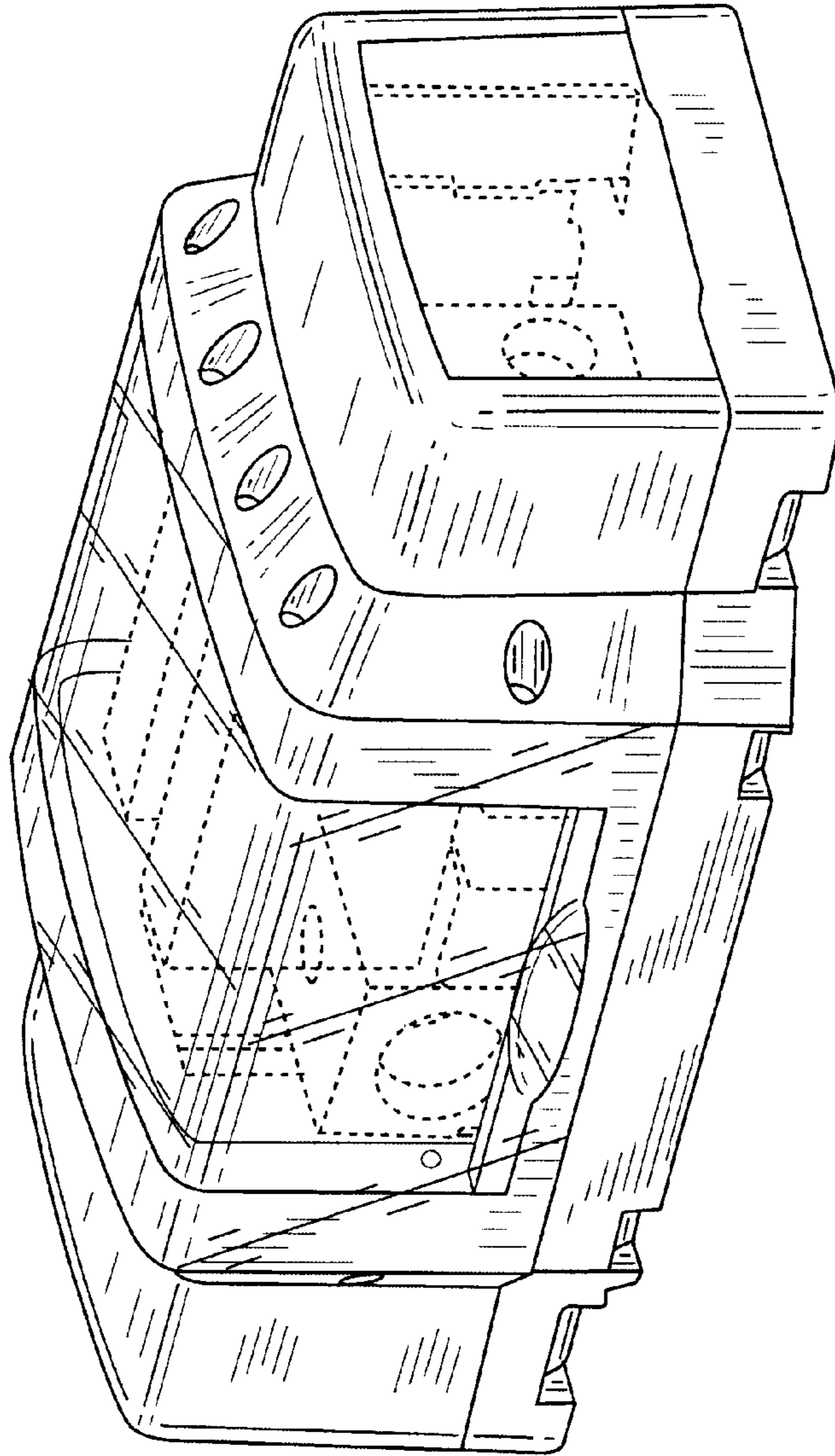


**FIG. 7**

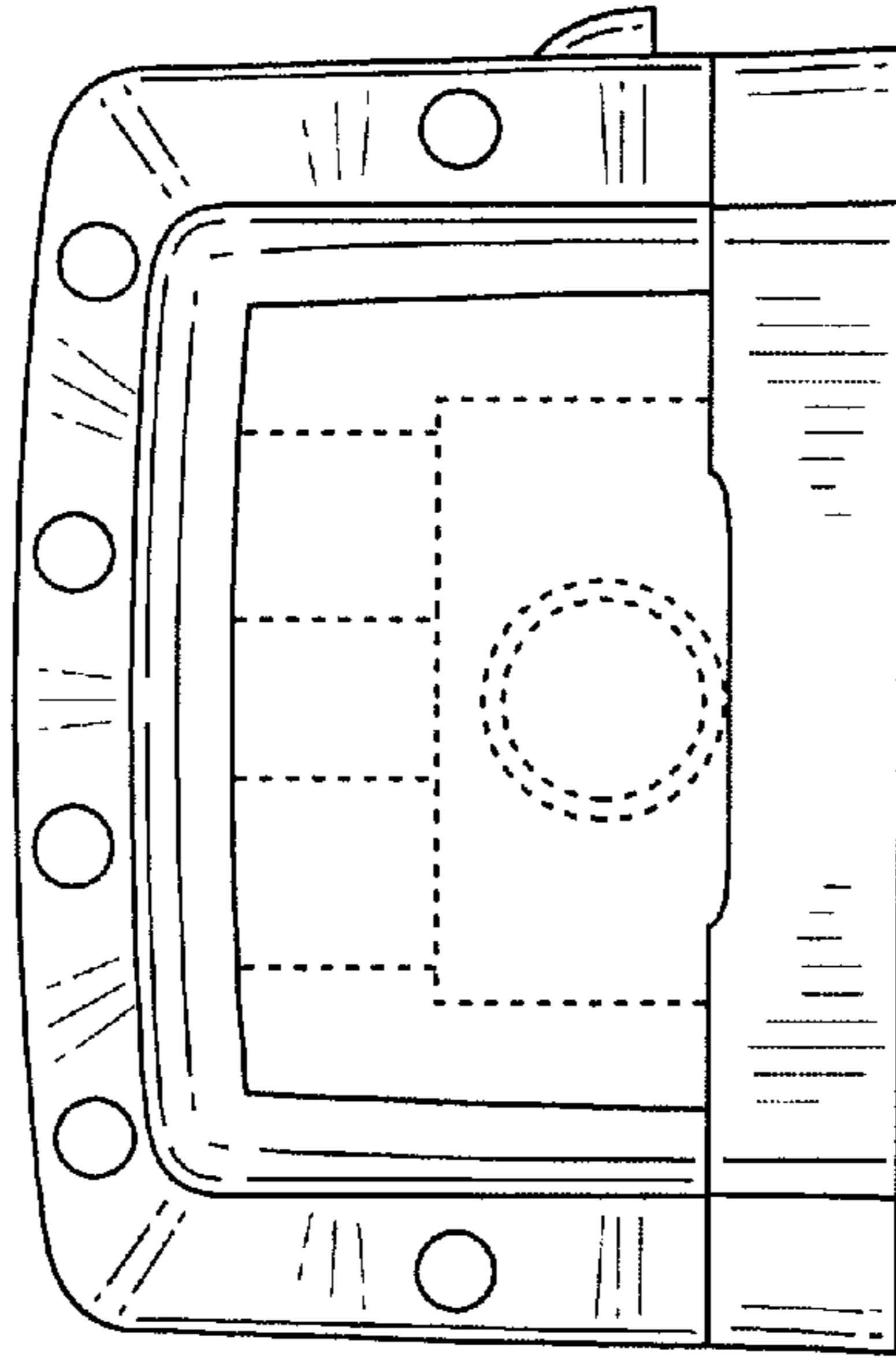


**FIG. 8**

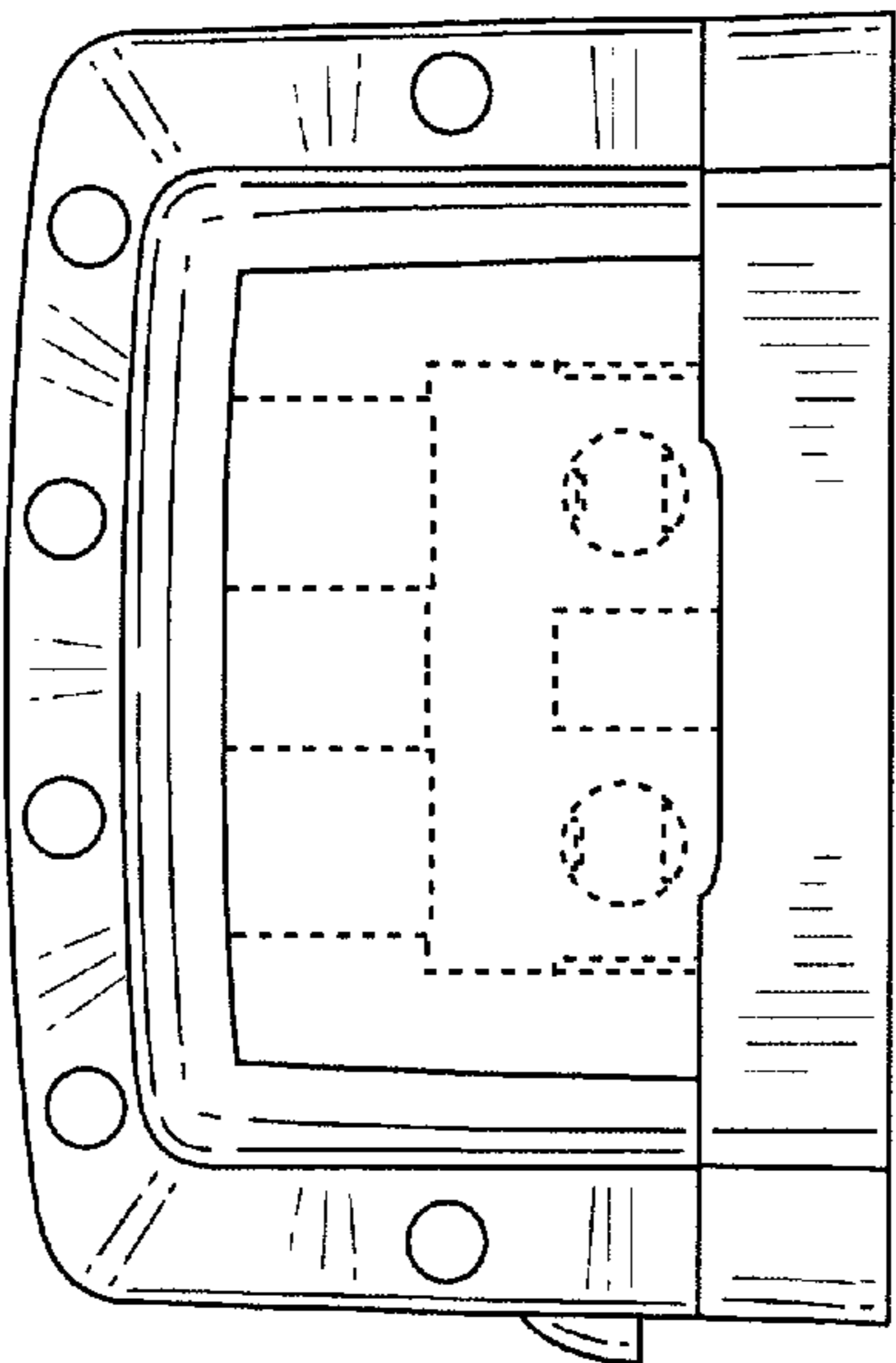




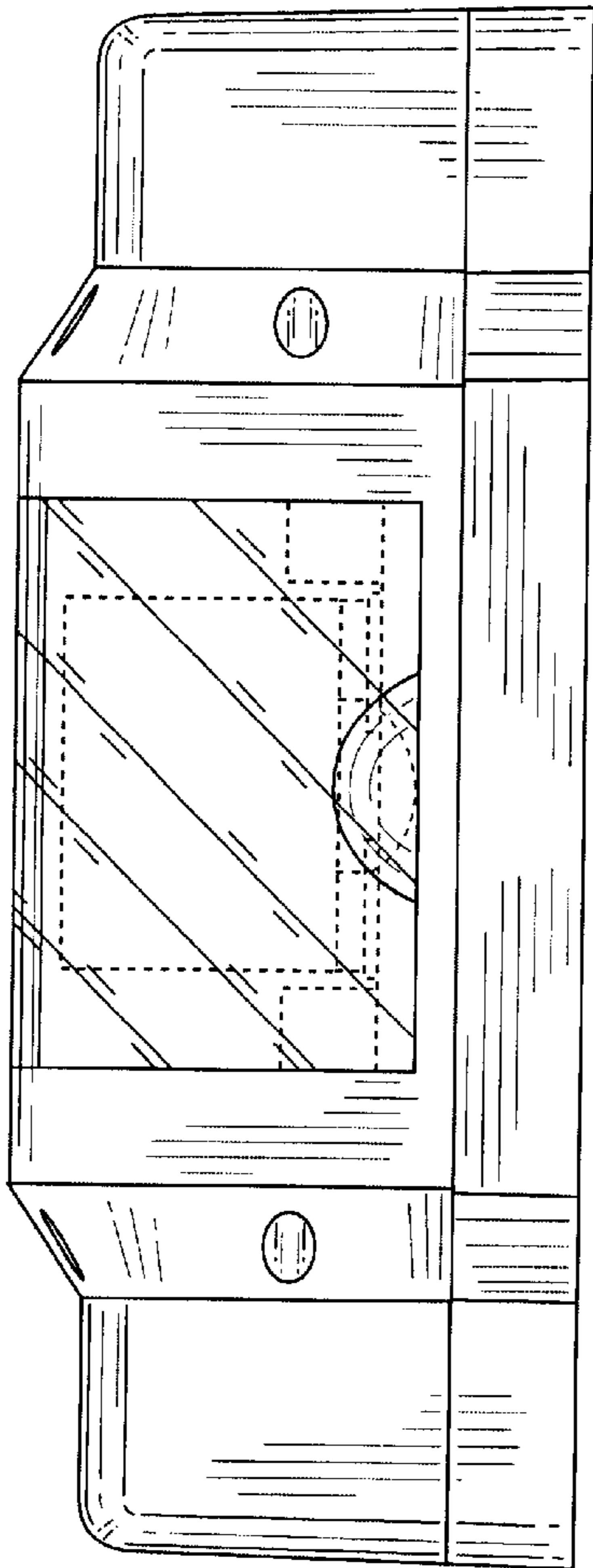
**FIG. 9**



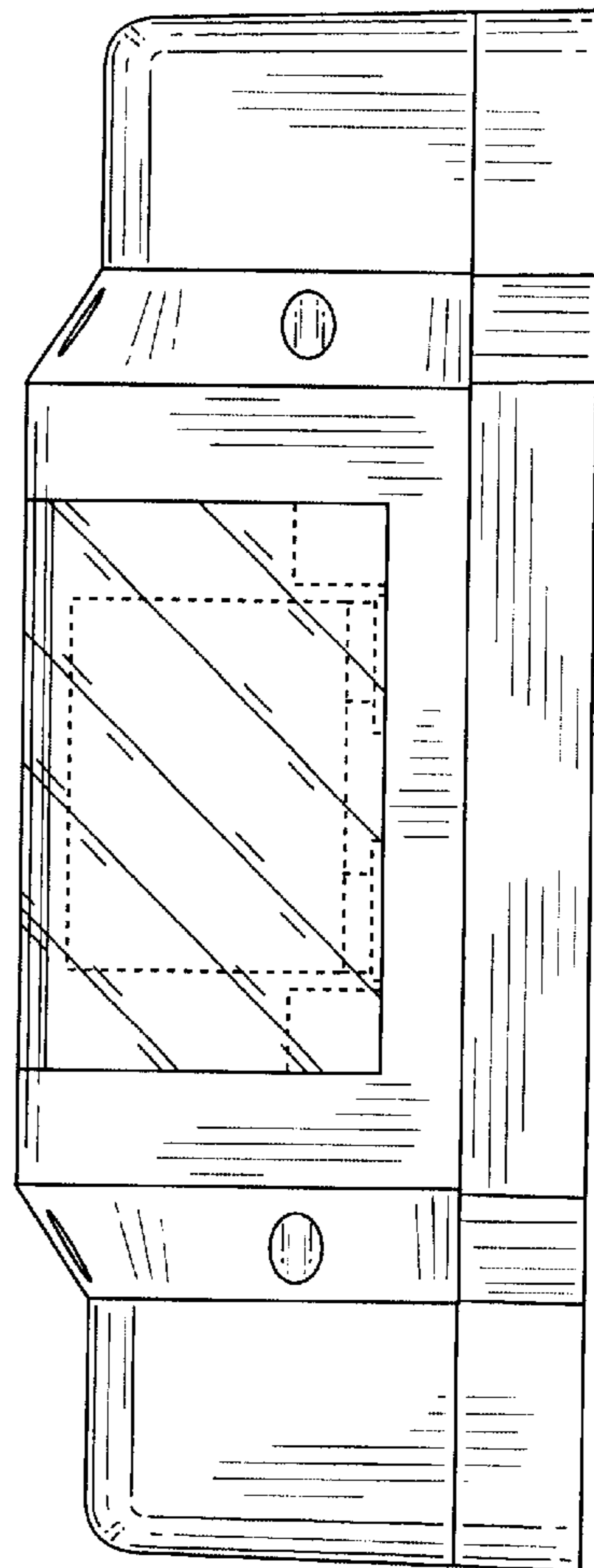
**FIG. 11**



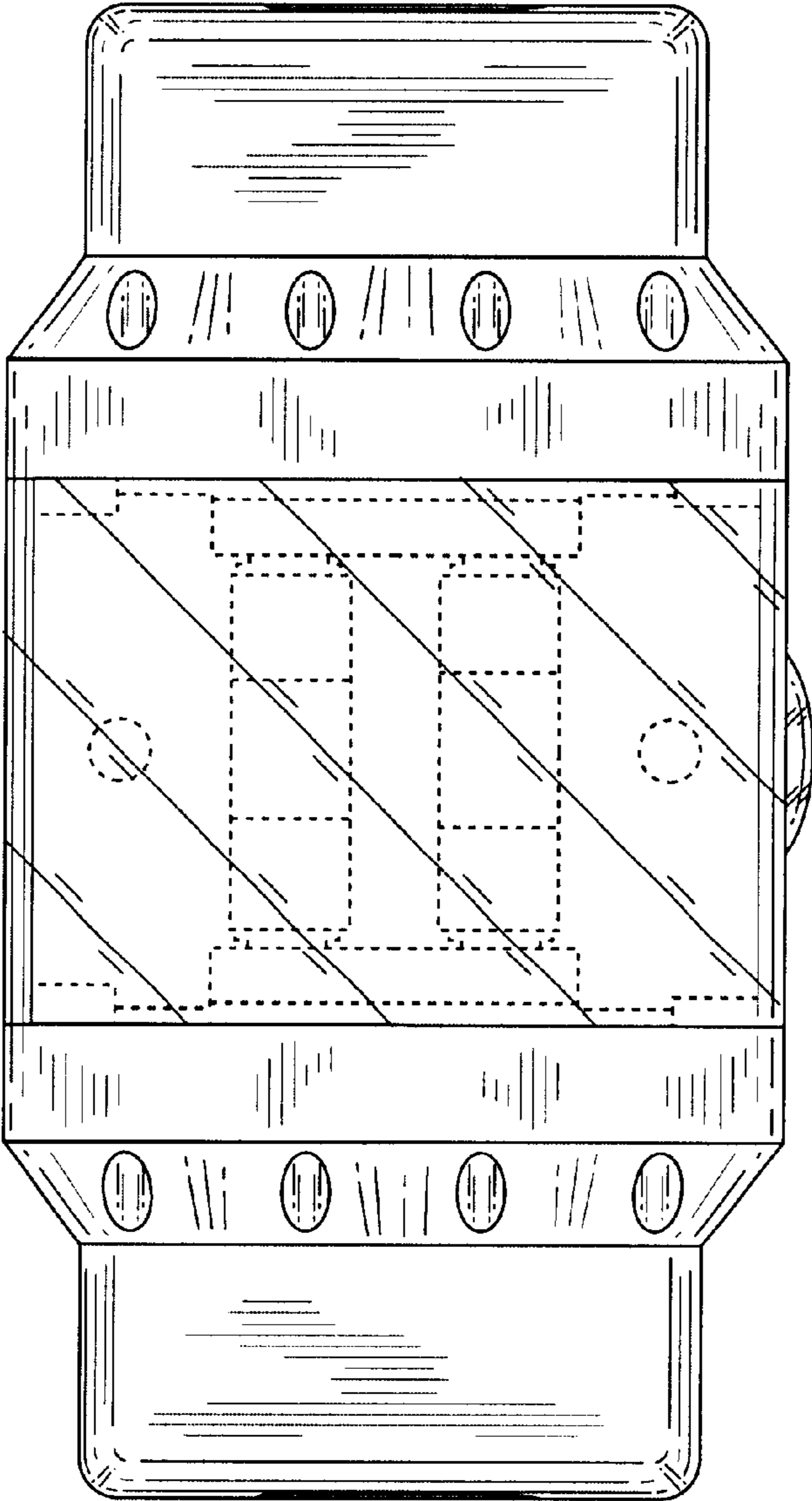
**FIG. 10**



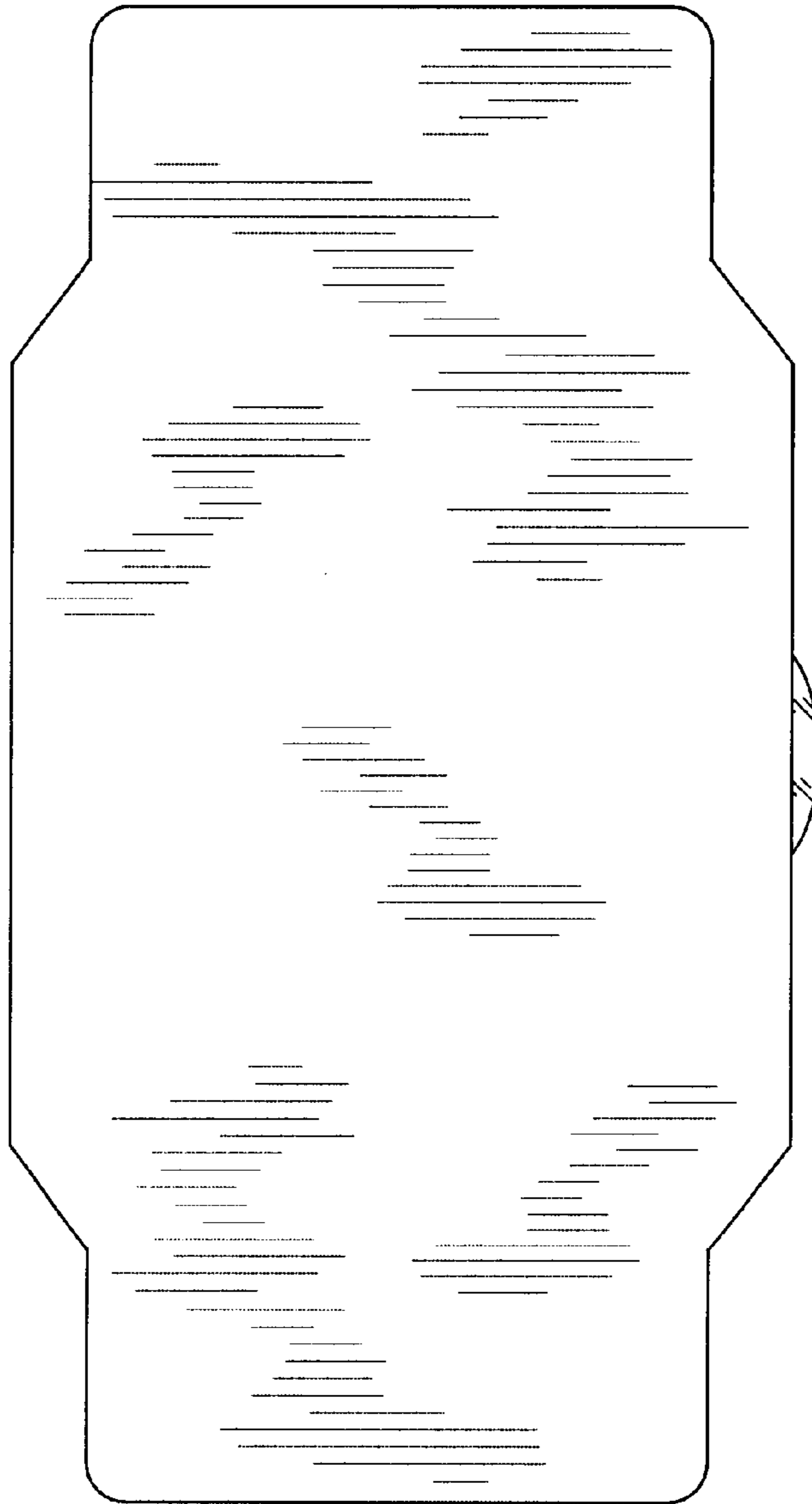
**FIG. 12**



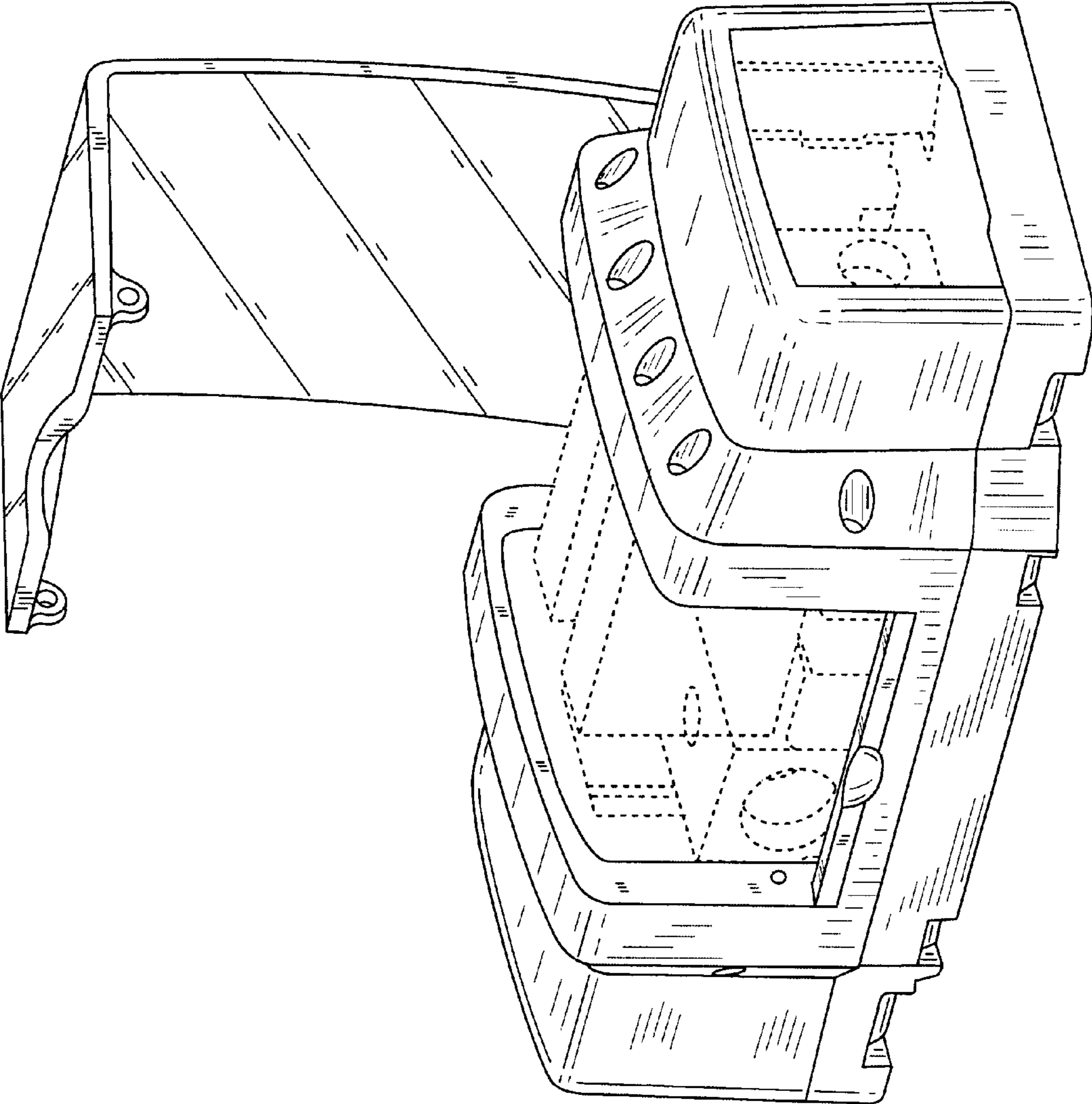
**FIG. 13**



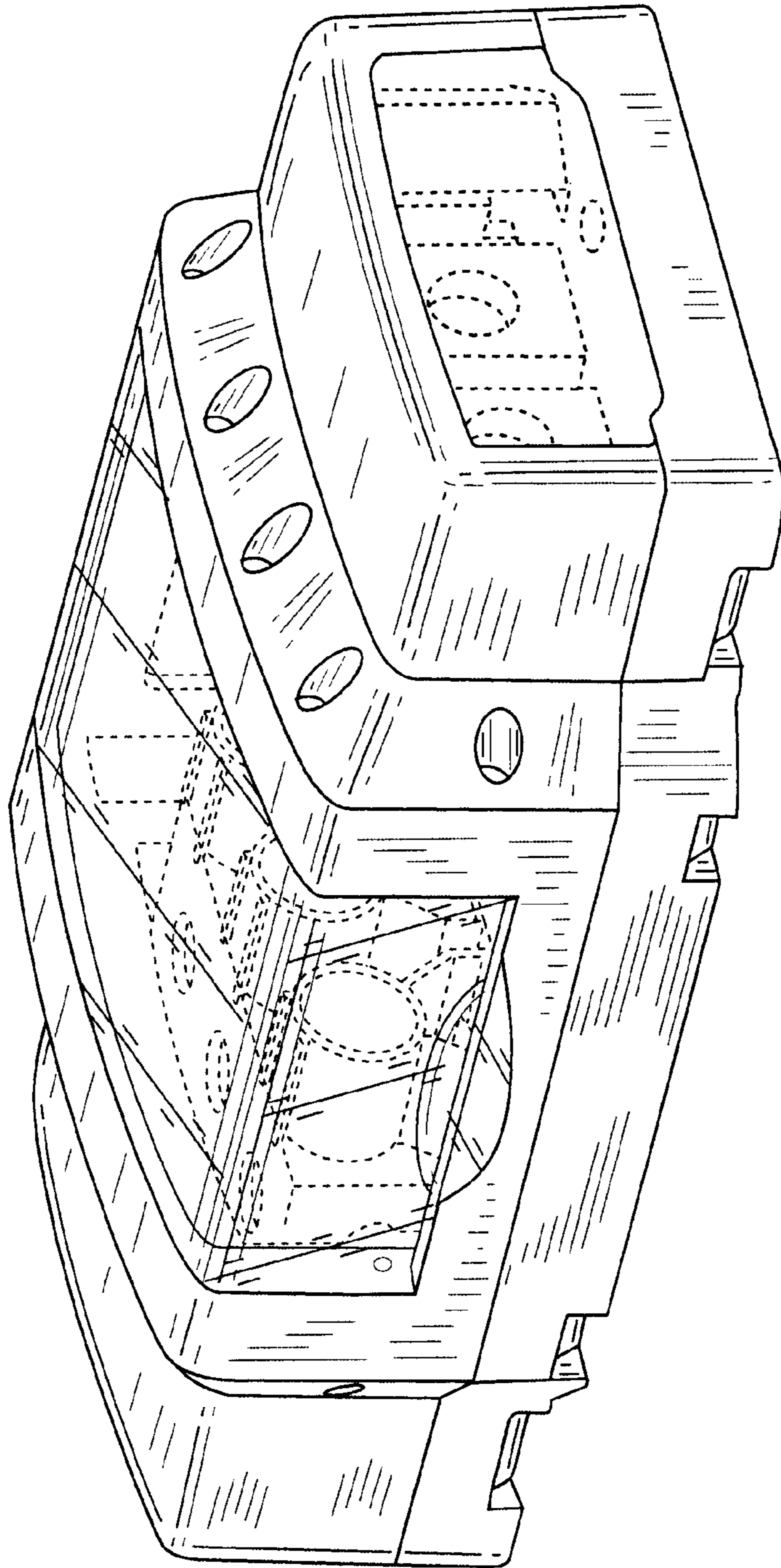
**FIG. 14**



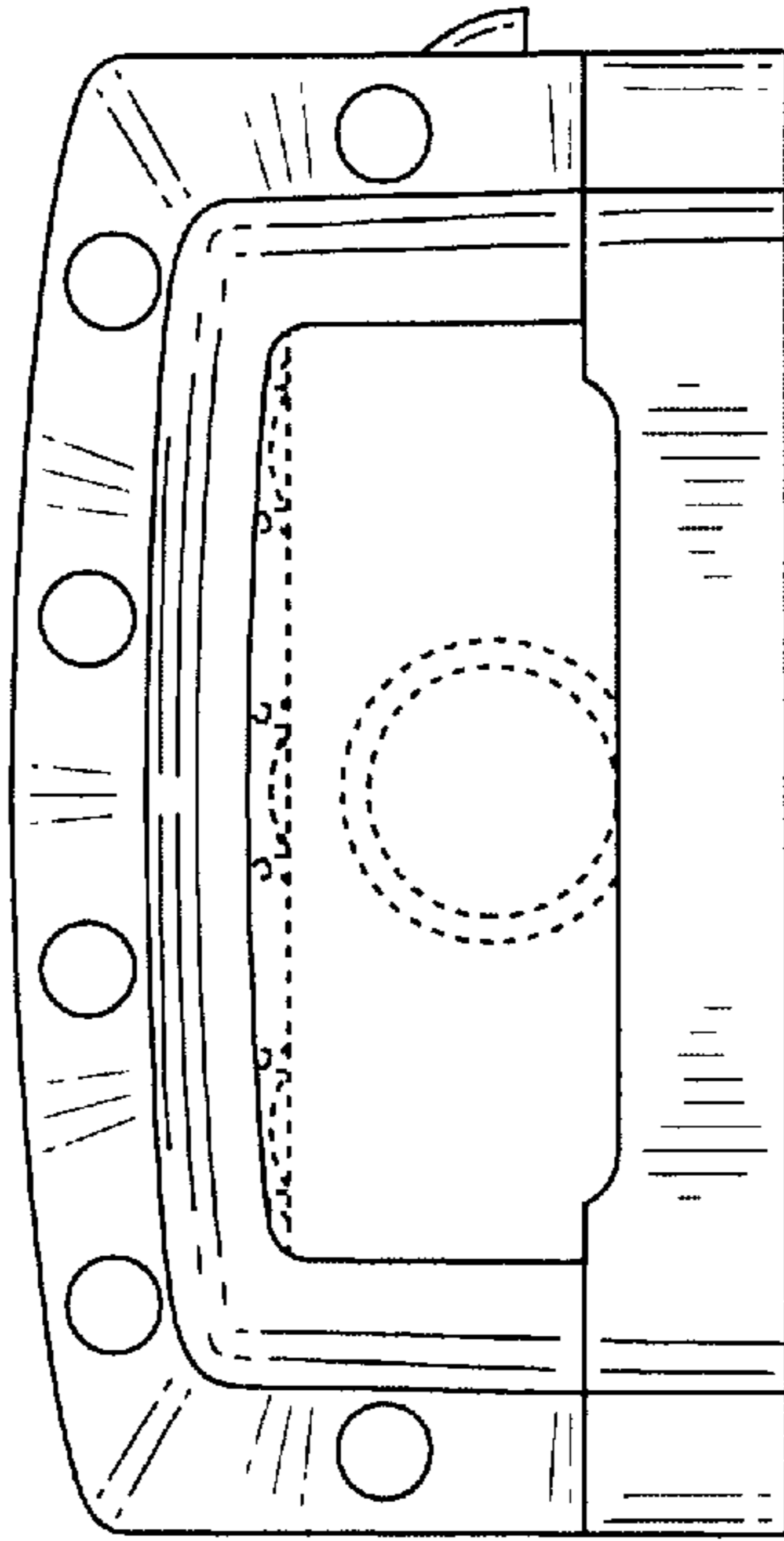
**FIG. 15**



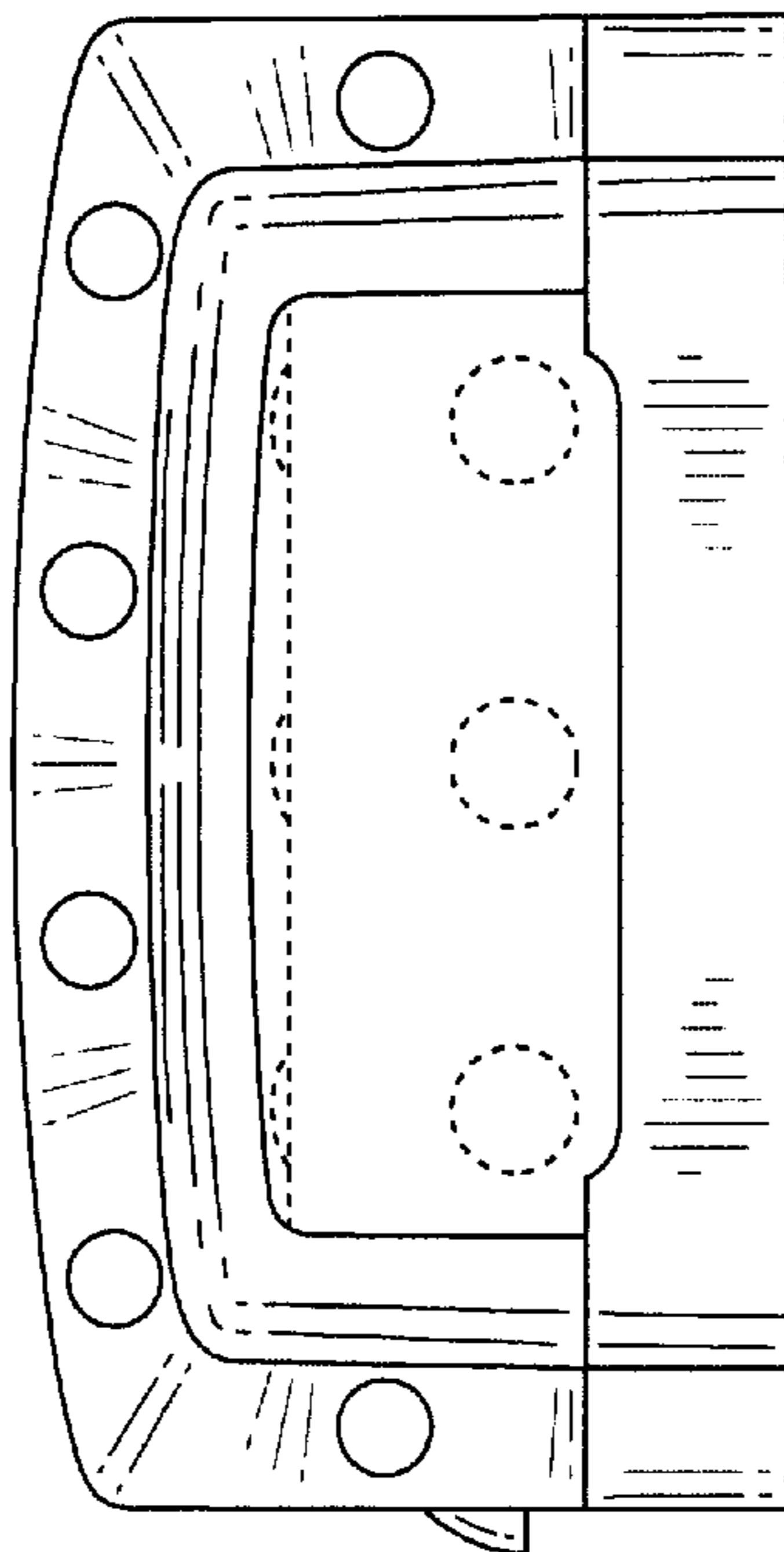
**FIG. 16**



**FIG. 17**

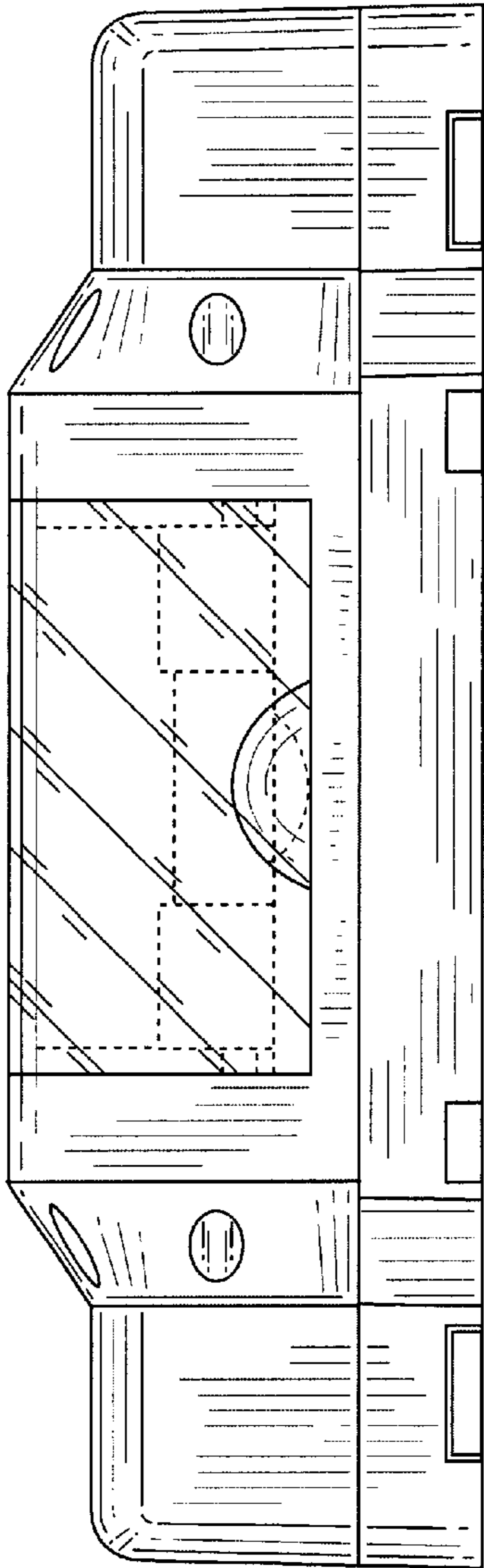


**FIG. 18**

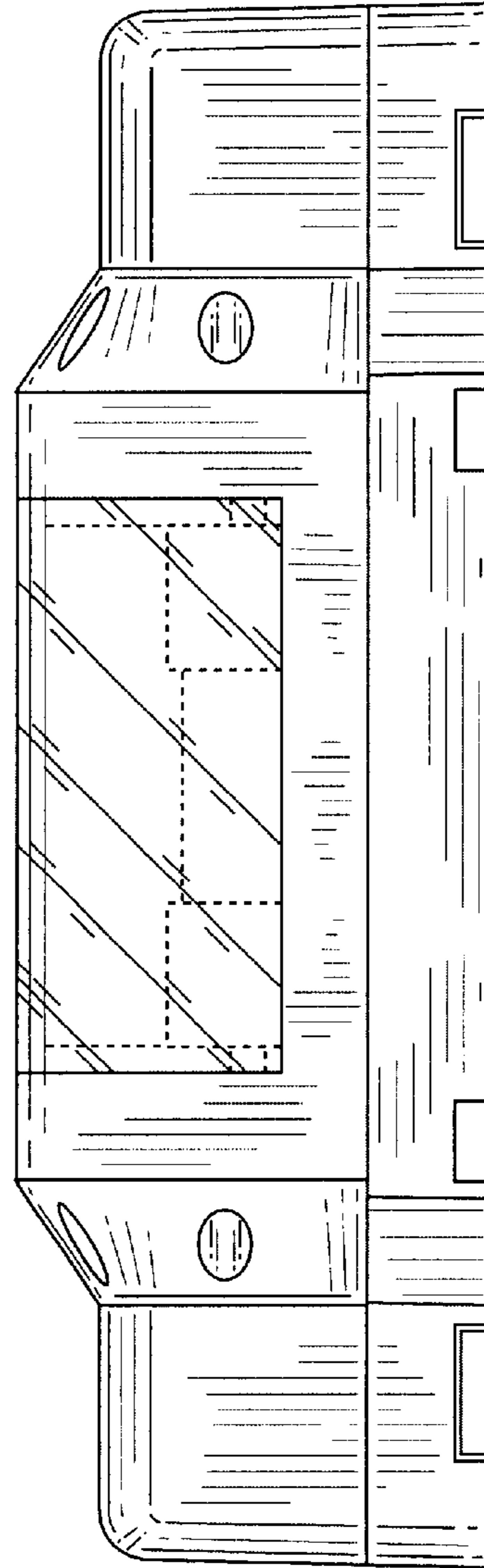


**FIG. 19**

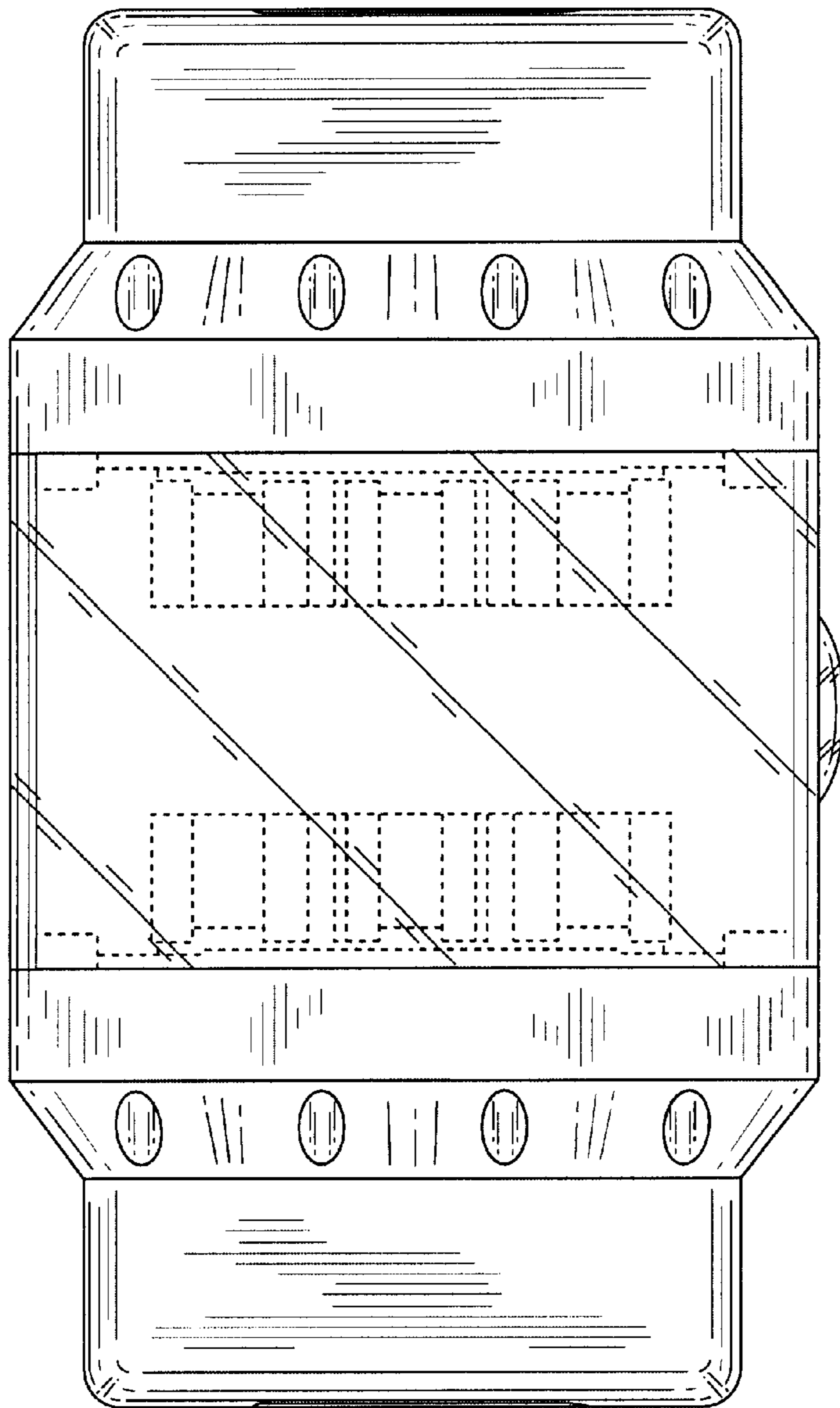




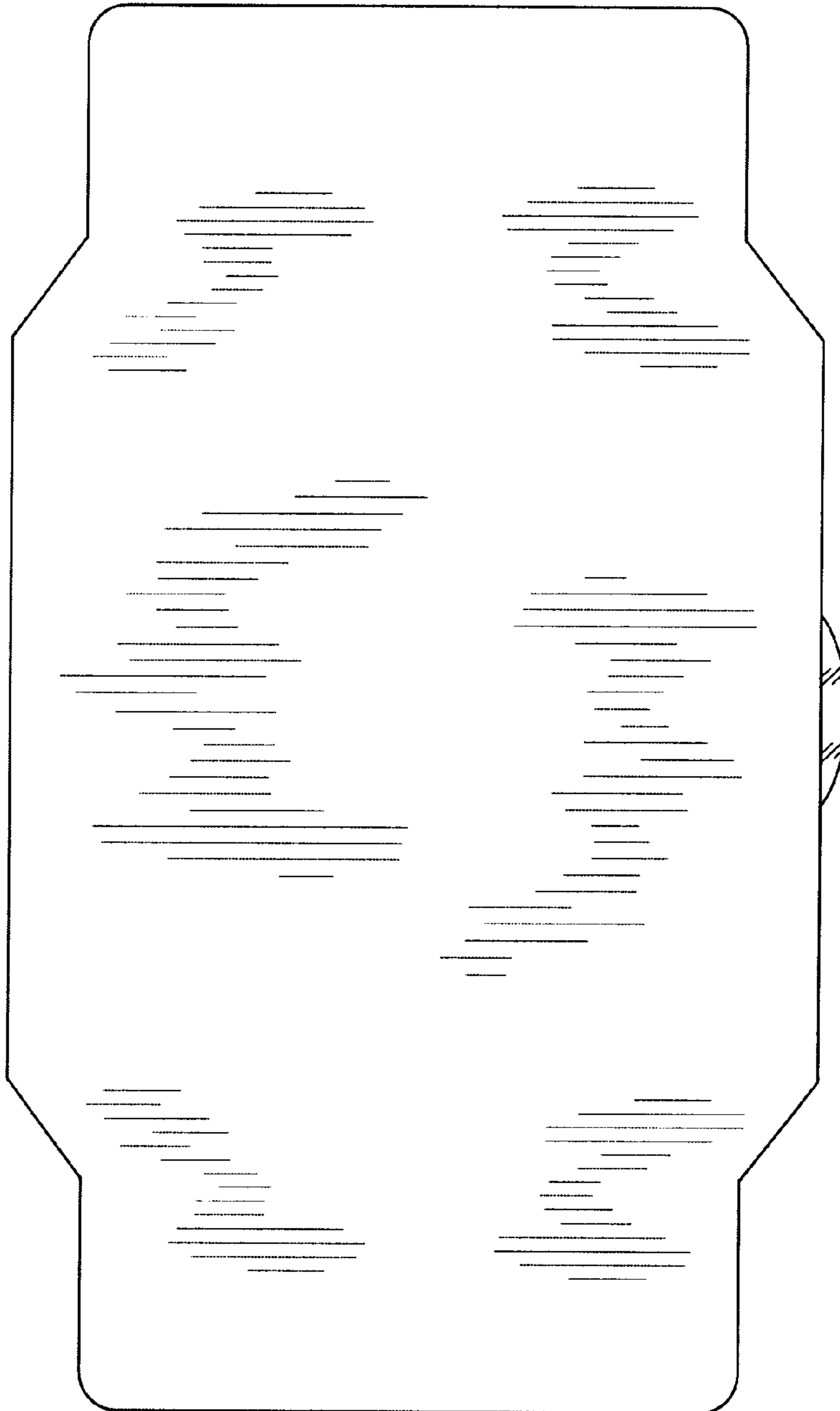
**FIG. 20**



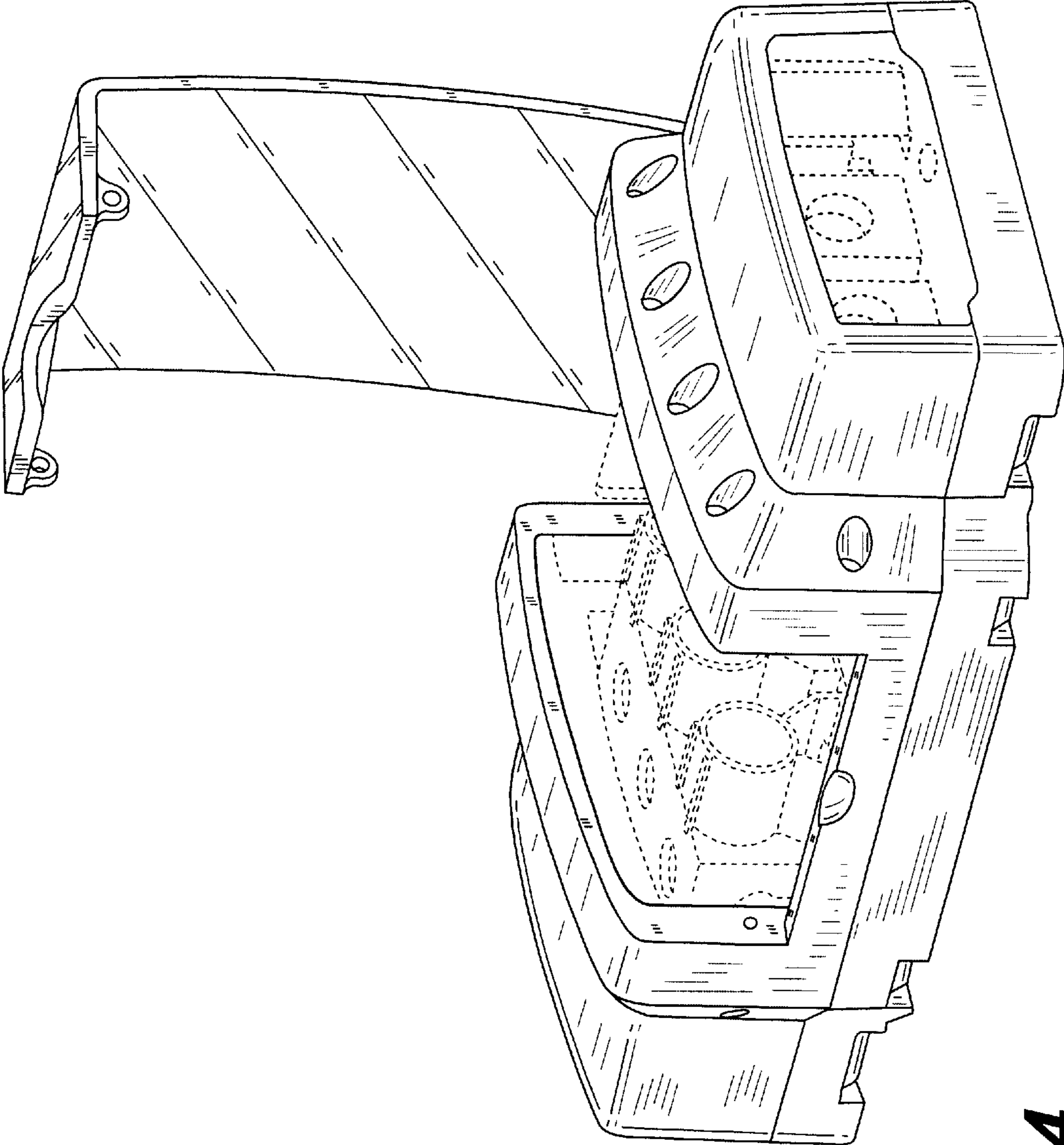
**FIG. 21**



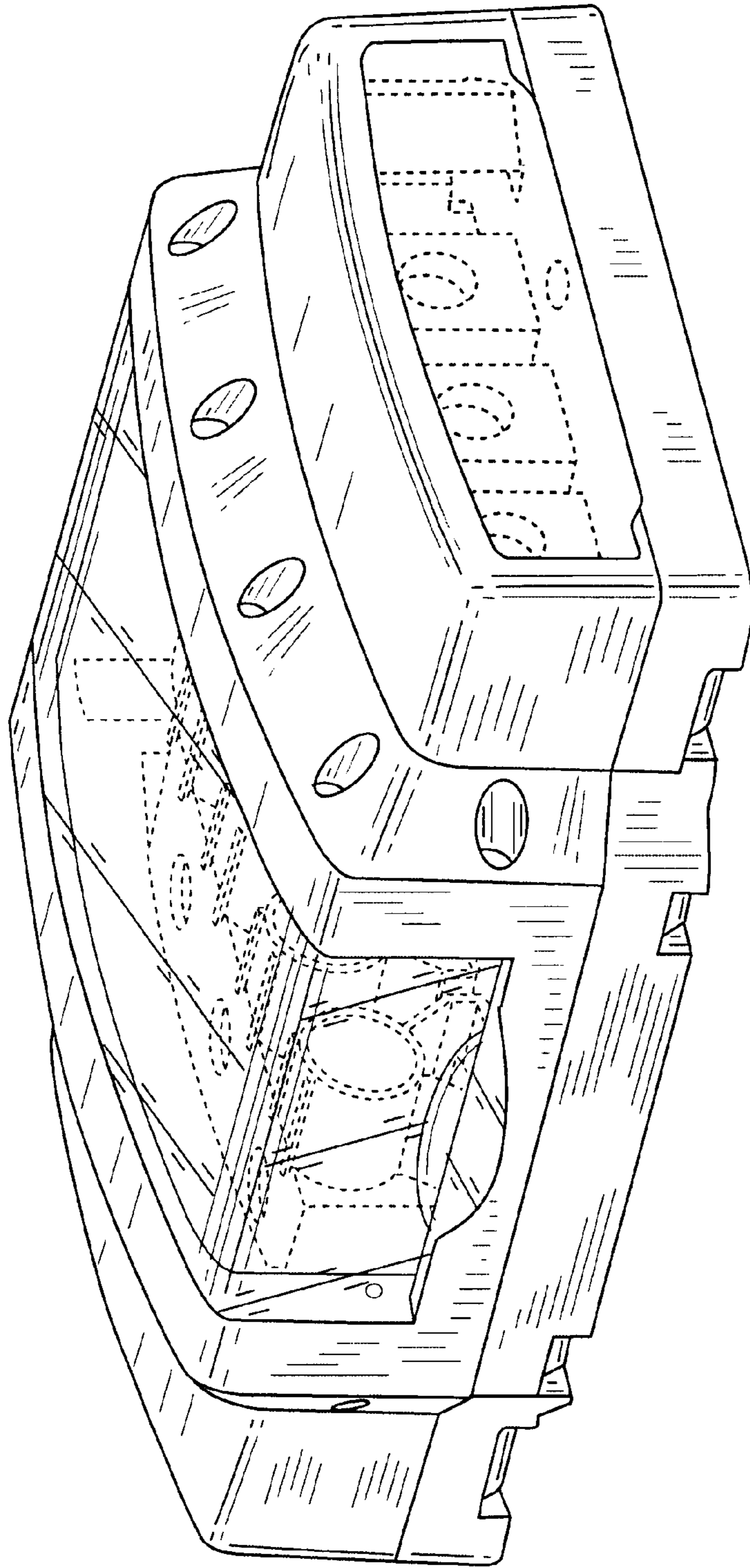
**FIG. 22**



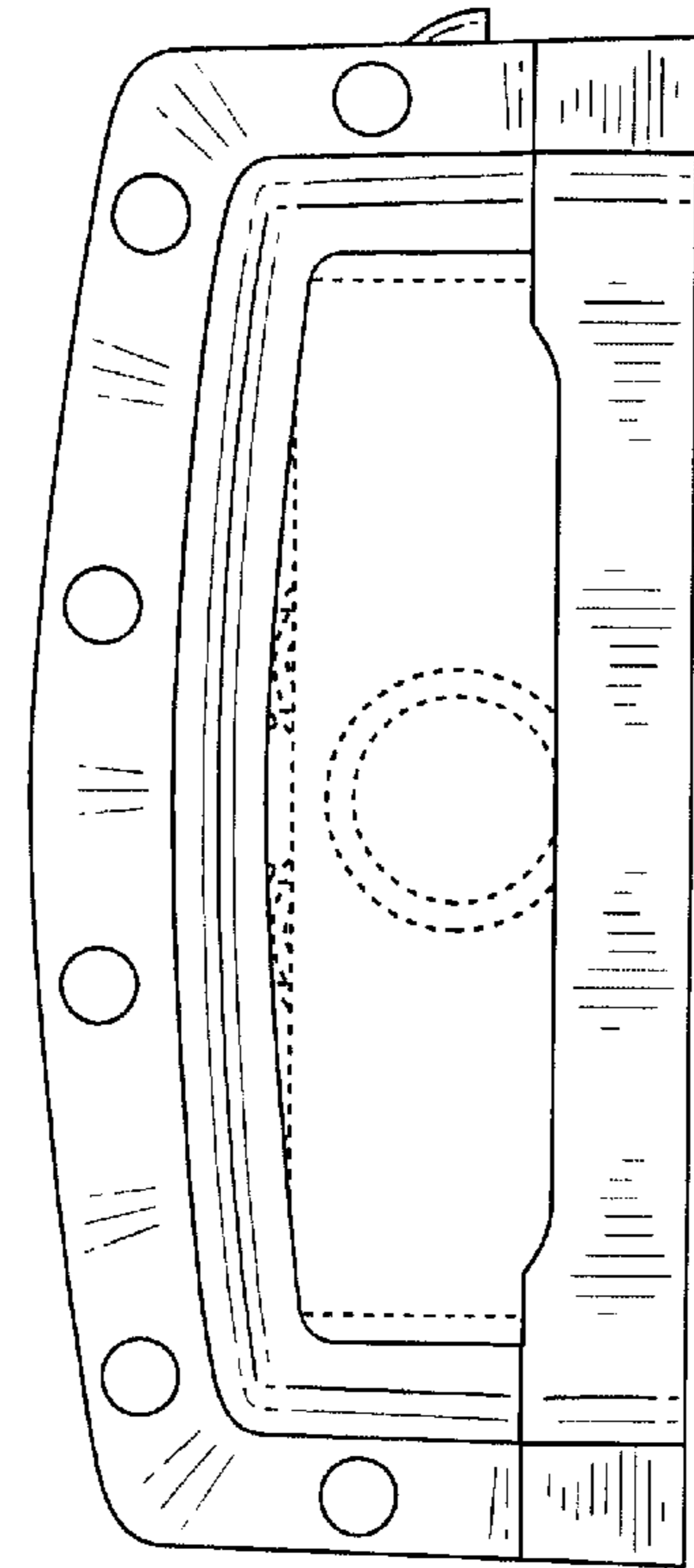
**FIG. 23**



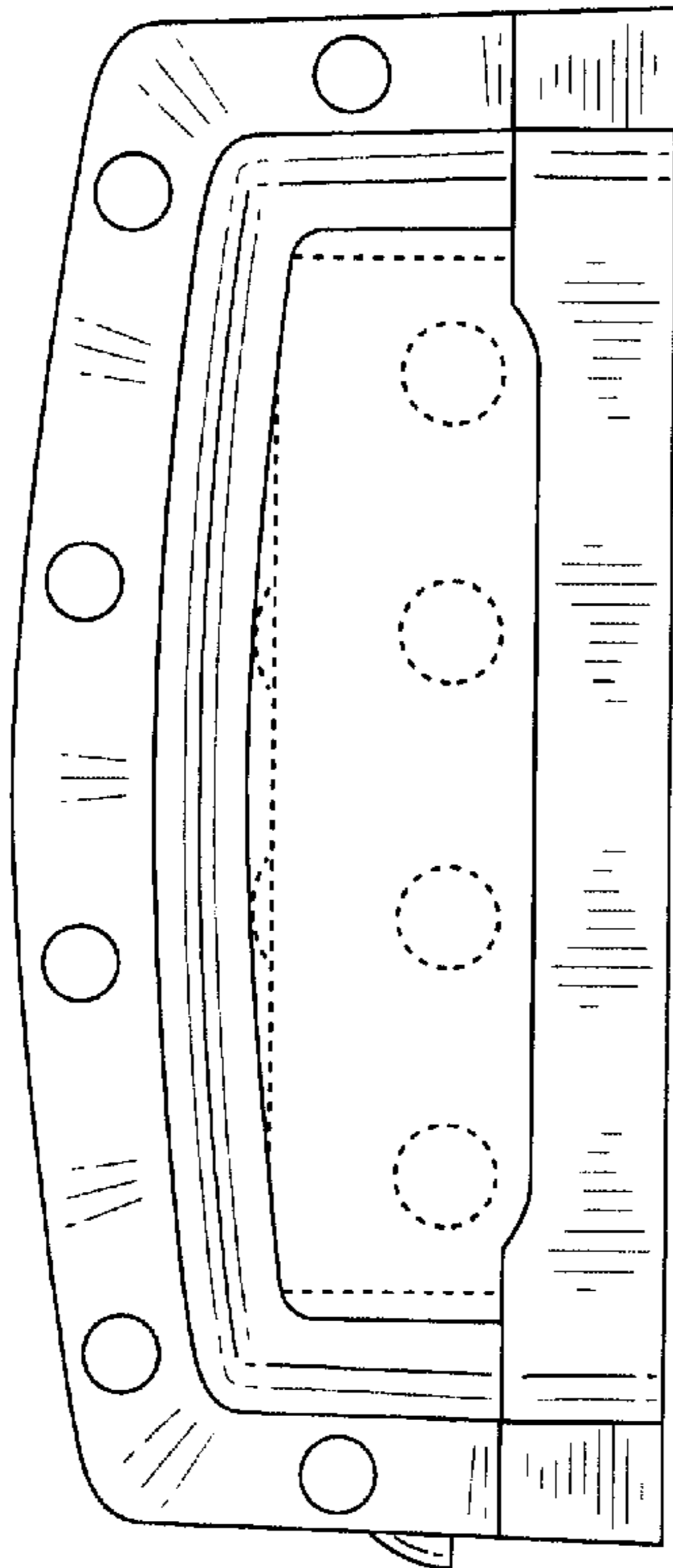
**FIG. 24**



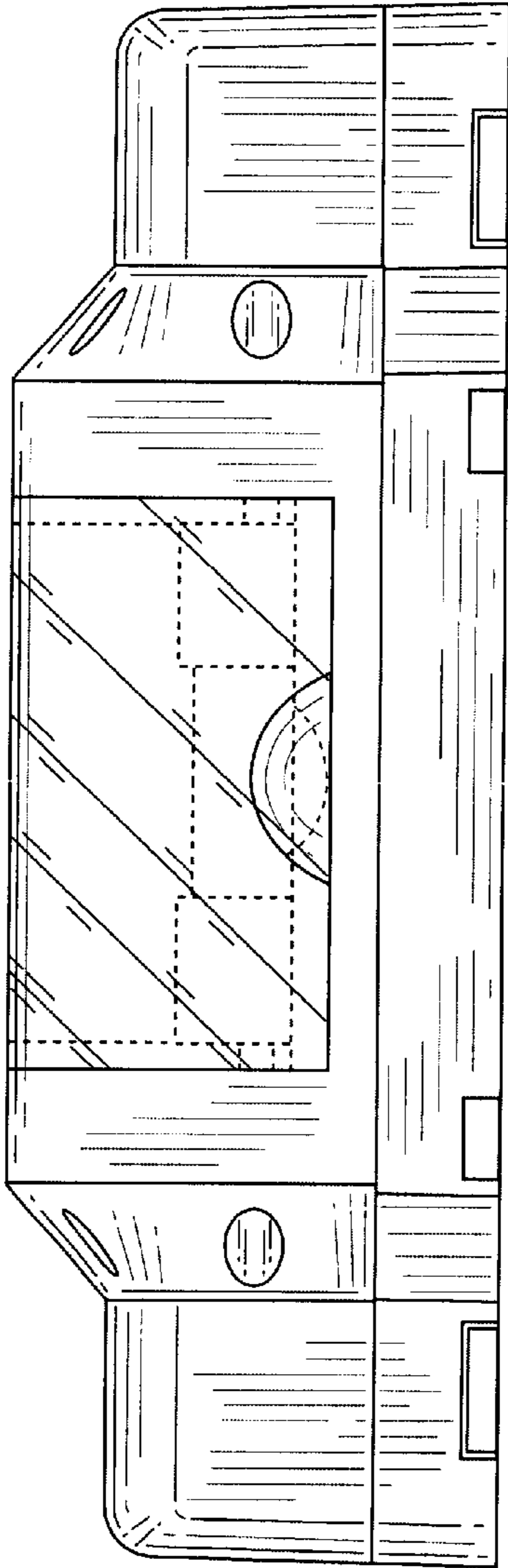
**FIG. 25**



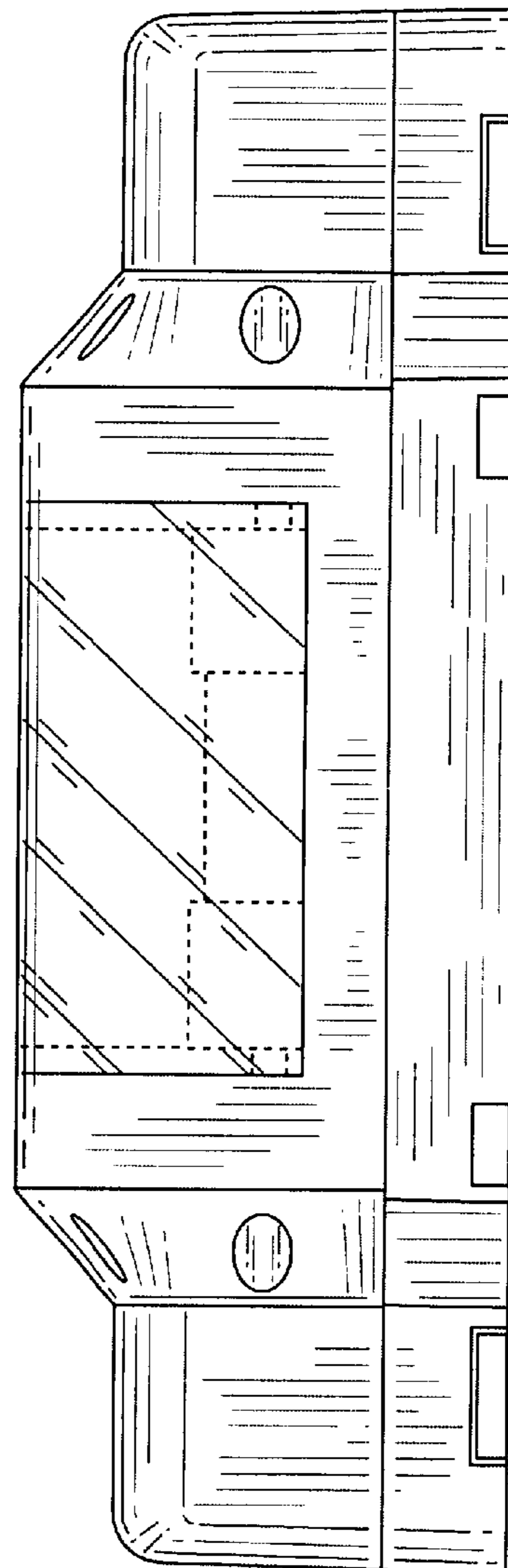
**FIG. 27**



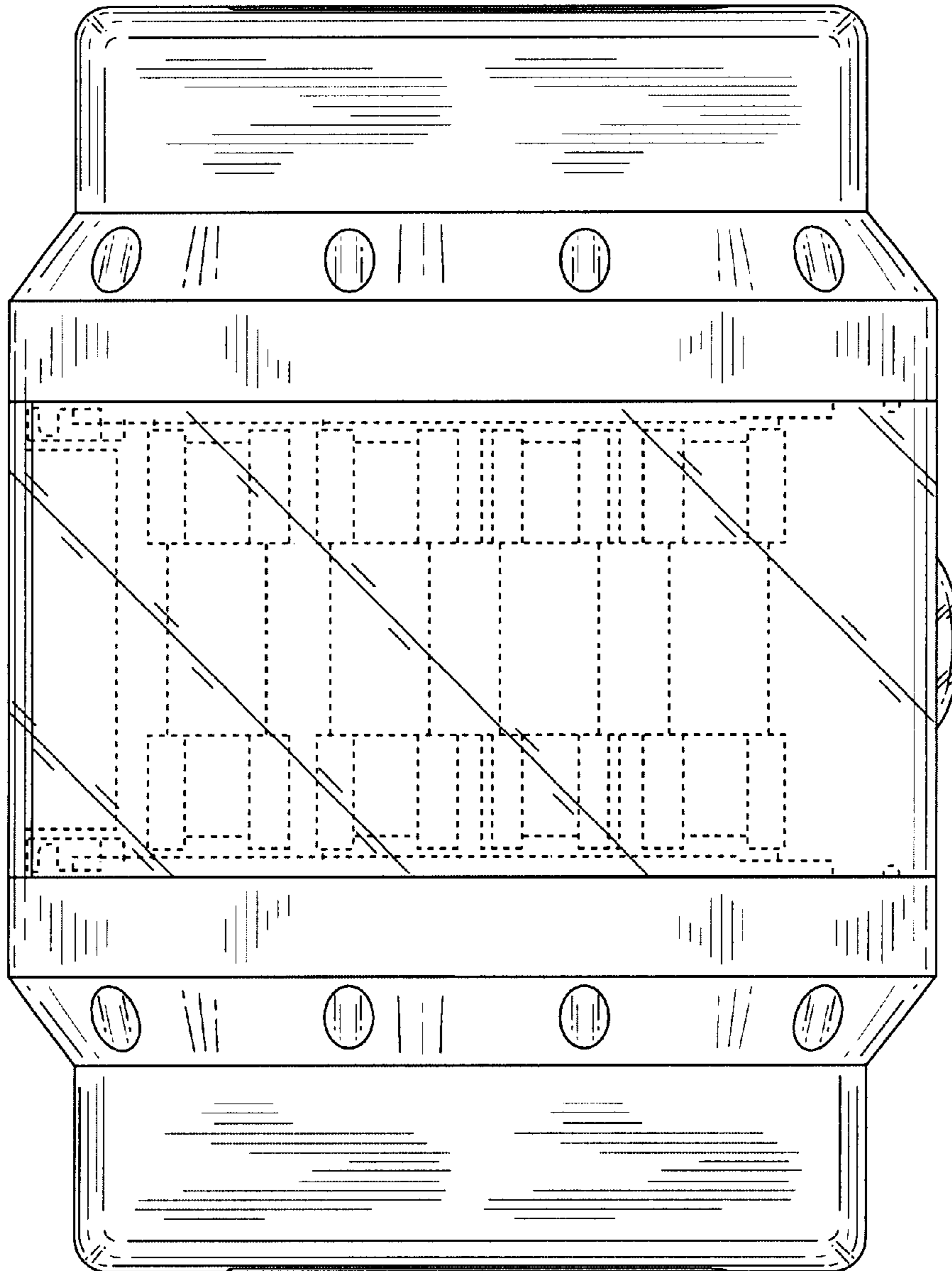
**FIG. 26**



**FIG. 28**

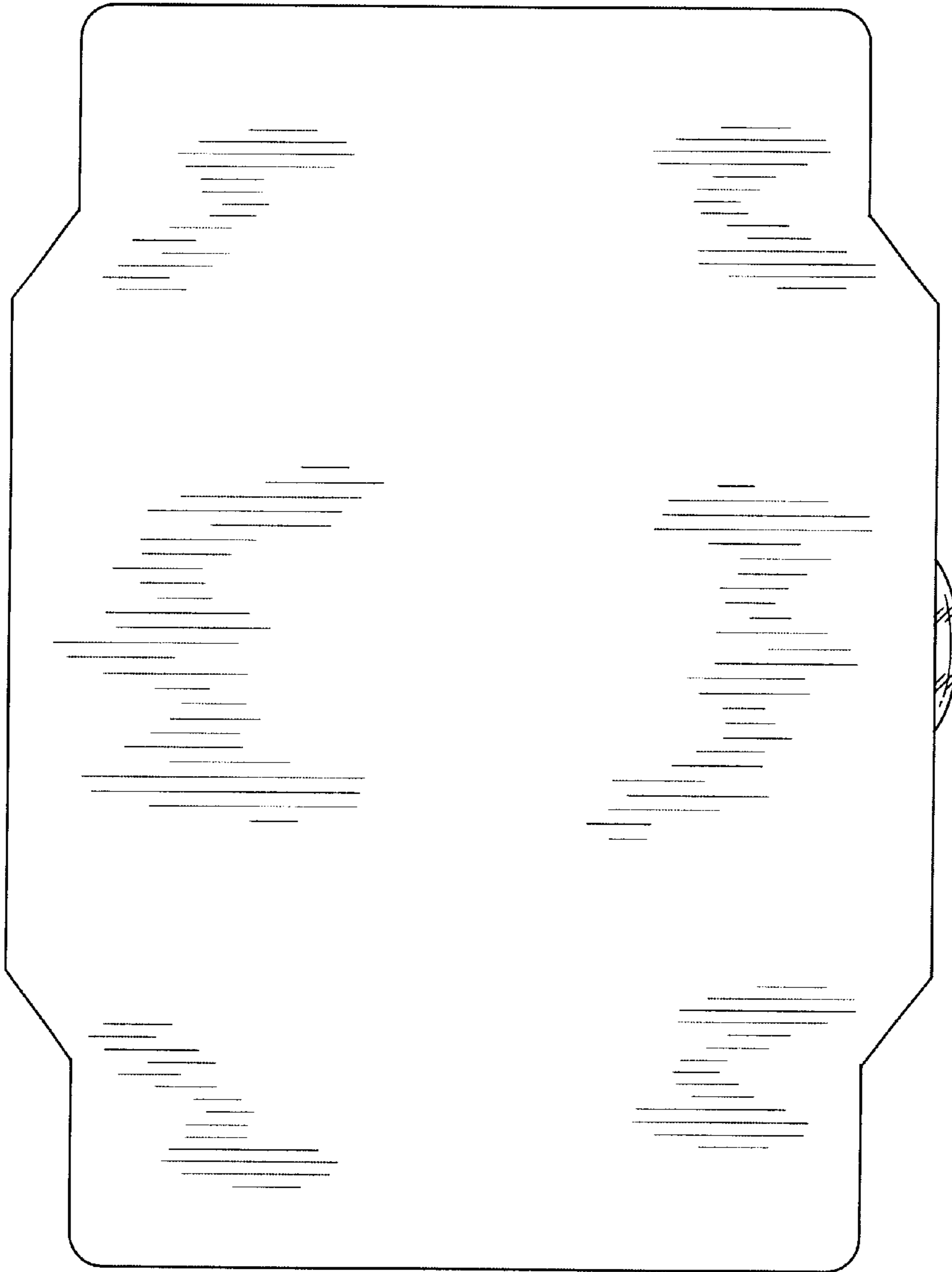


**FIG. 29**

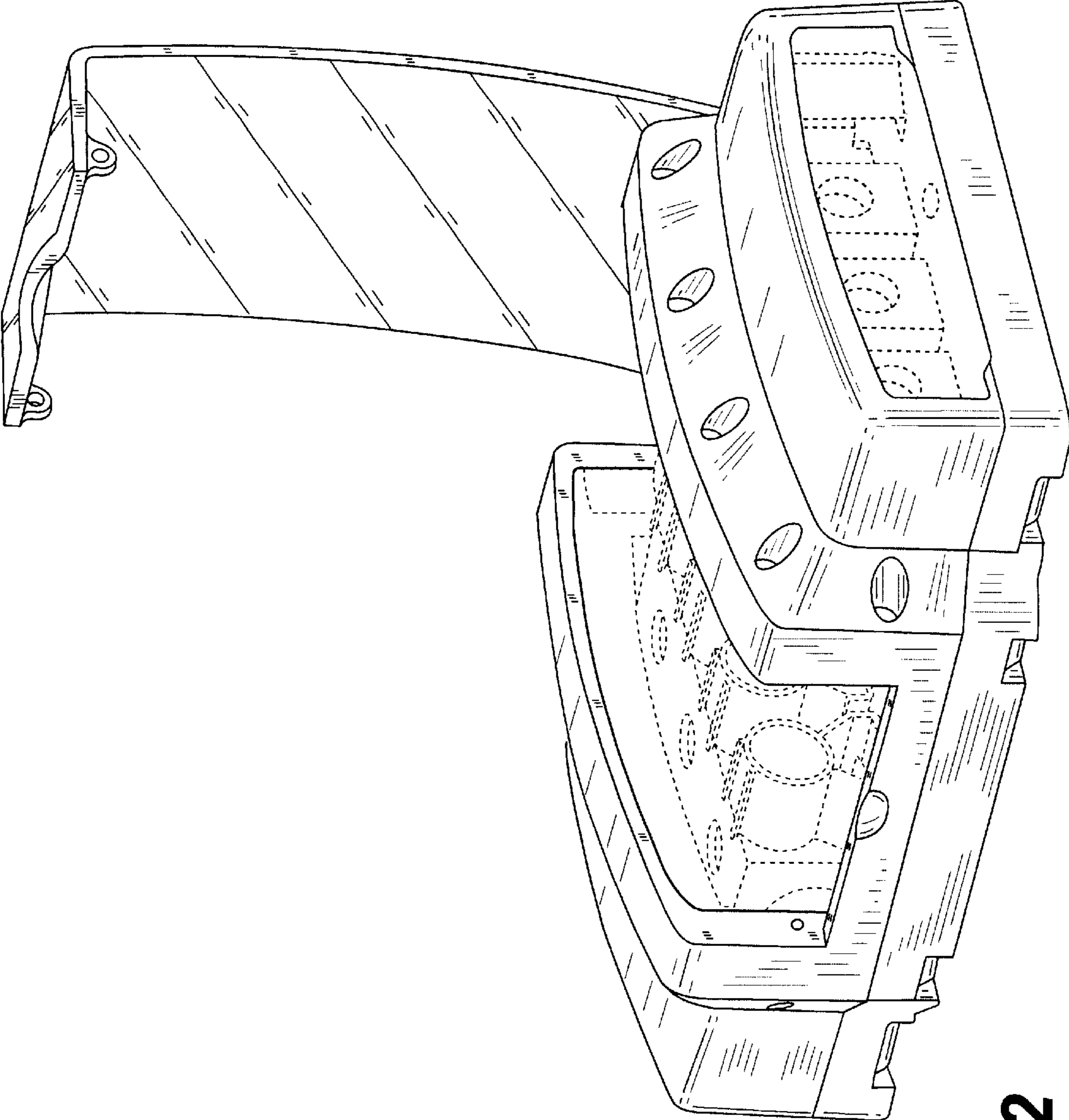


**FIG. 30**

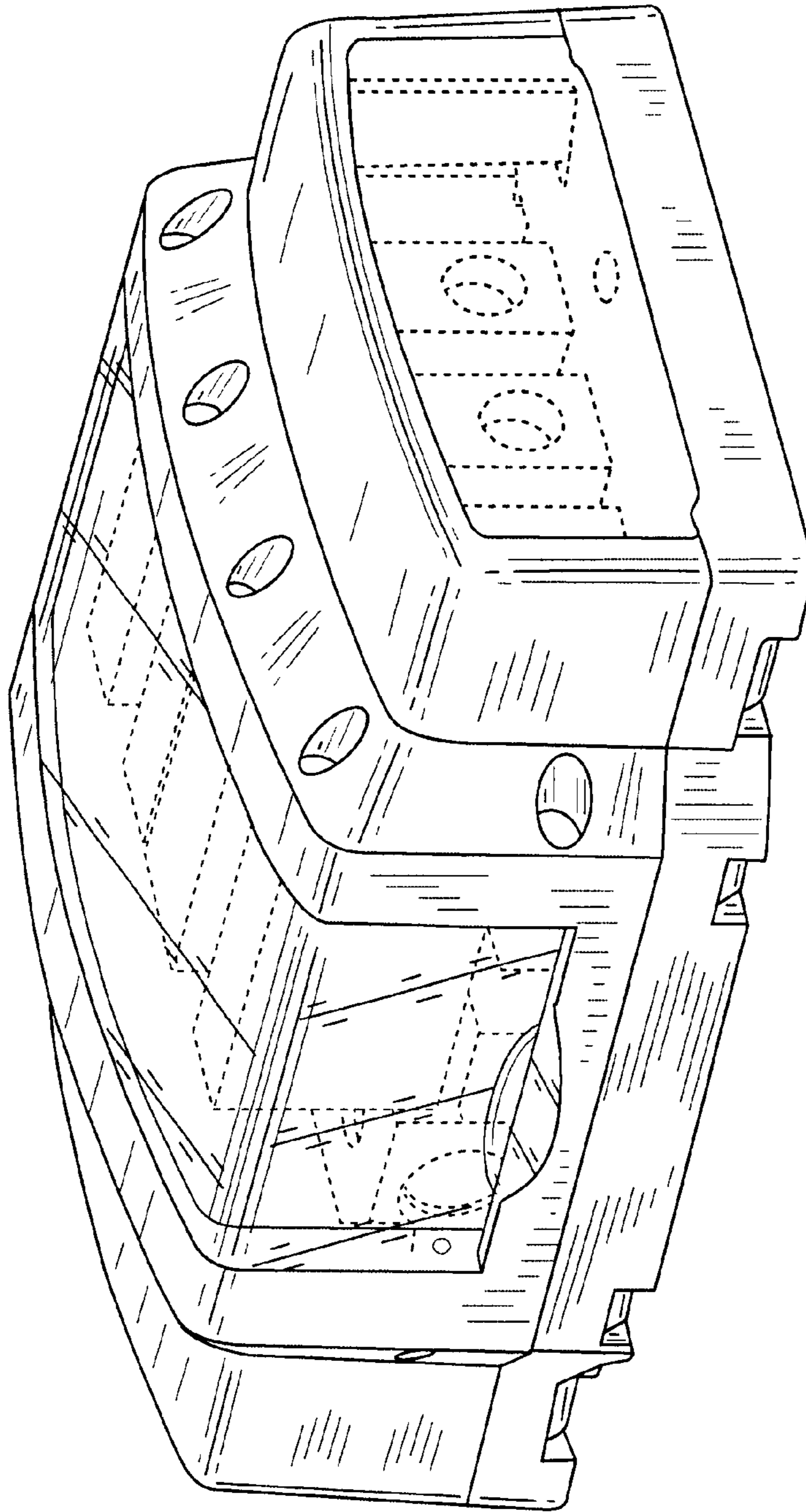




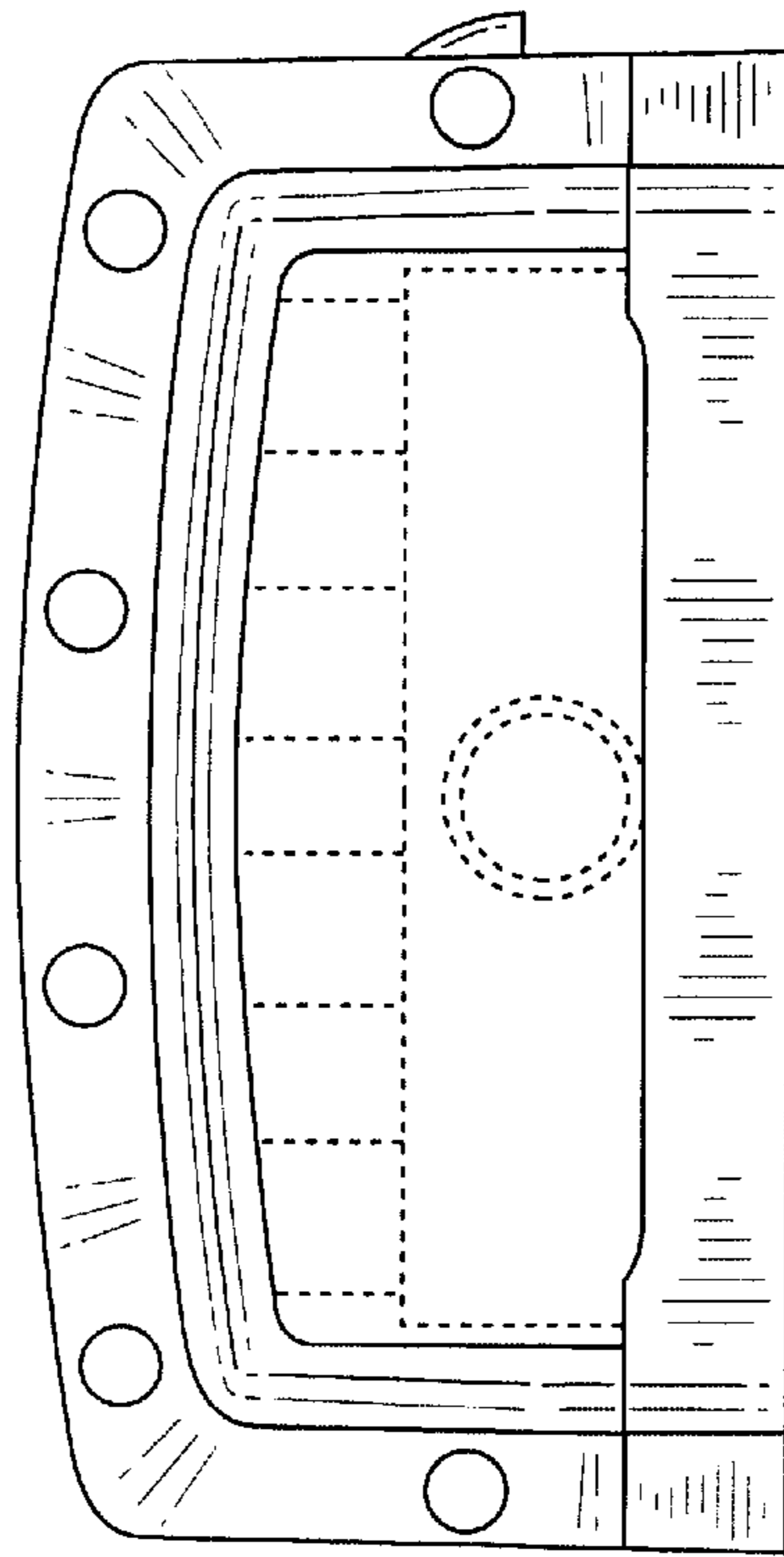
**FIG. 31**



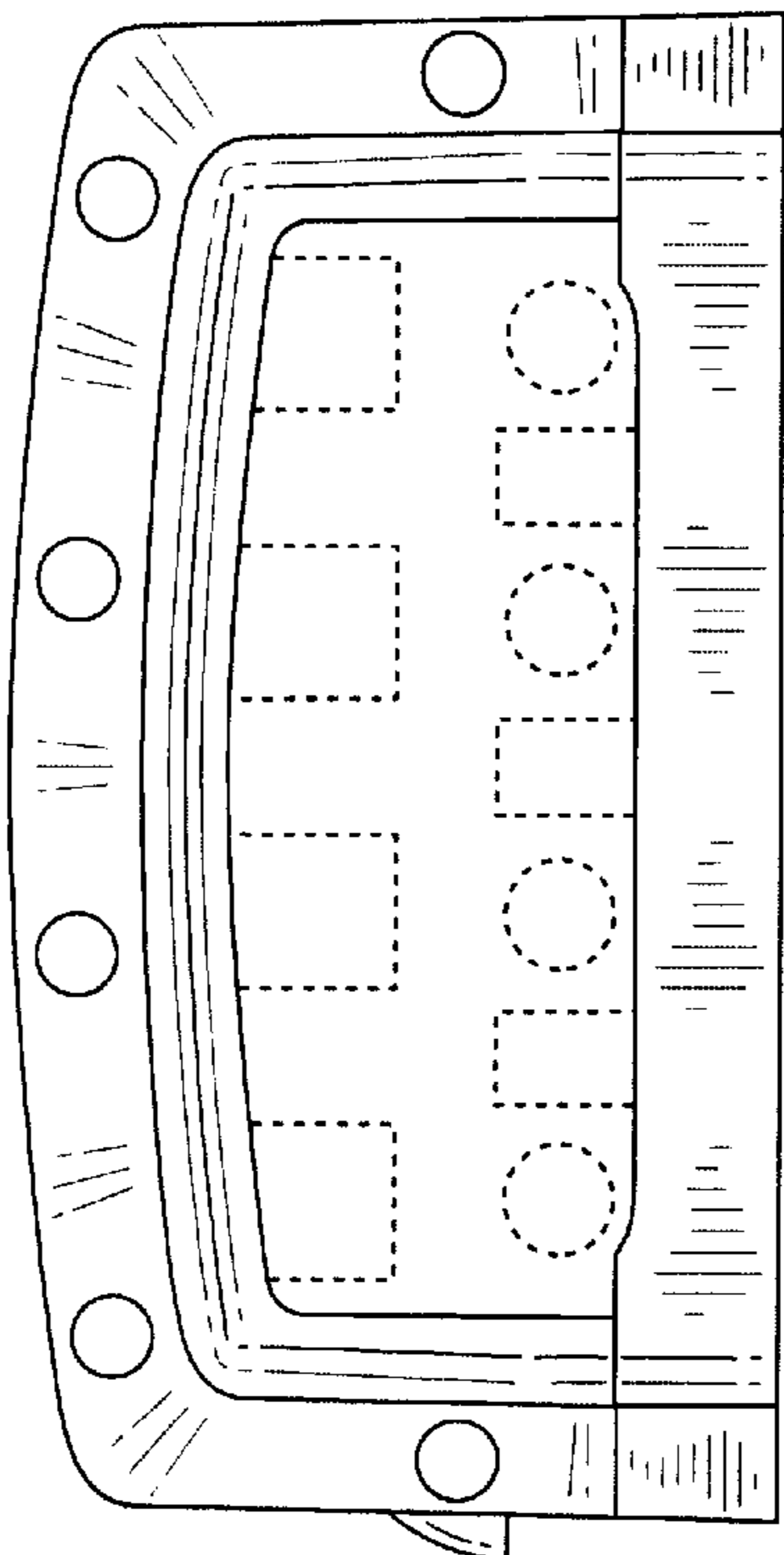
**FIG. 32**



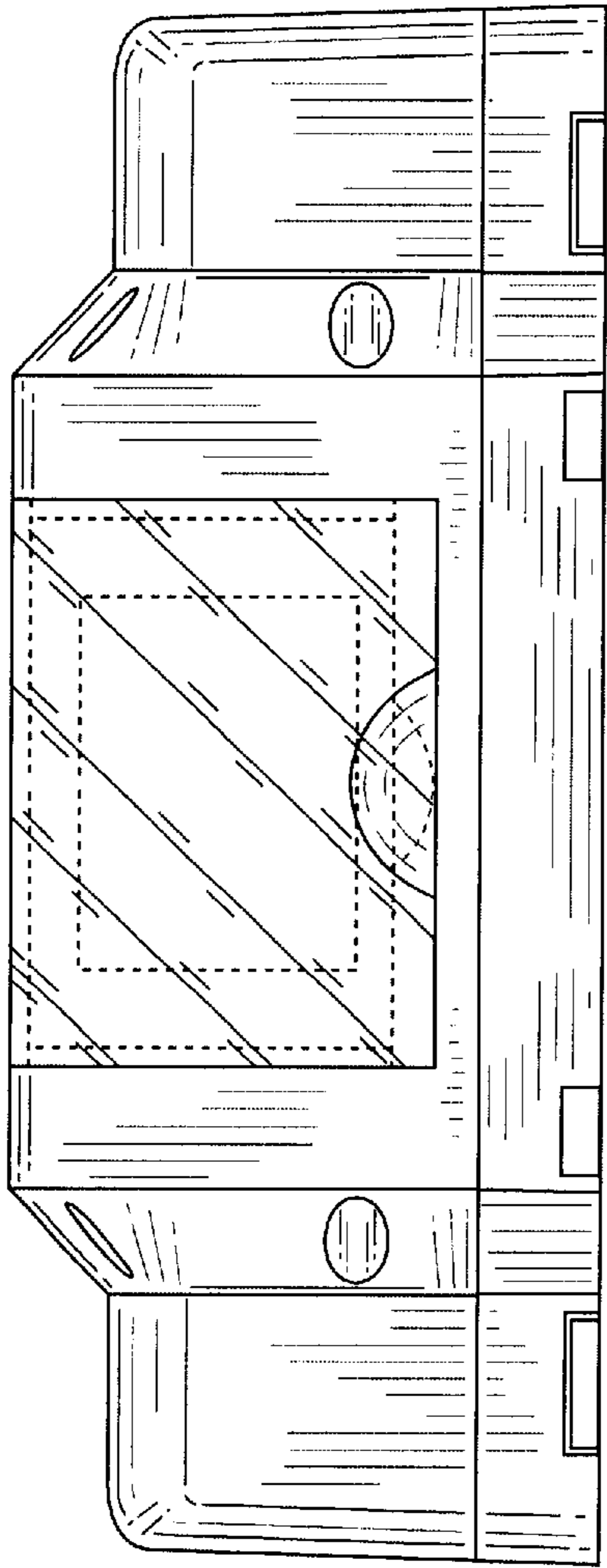
**FIG. 33**



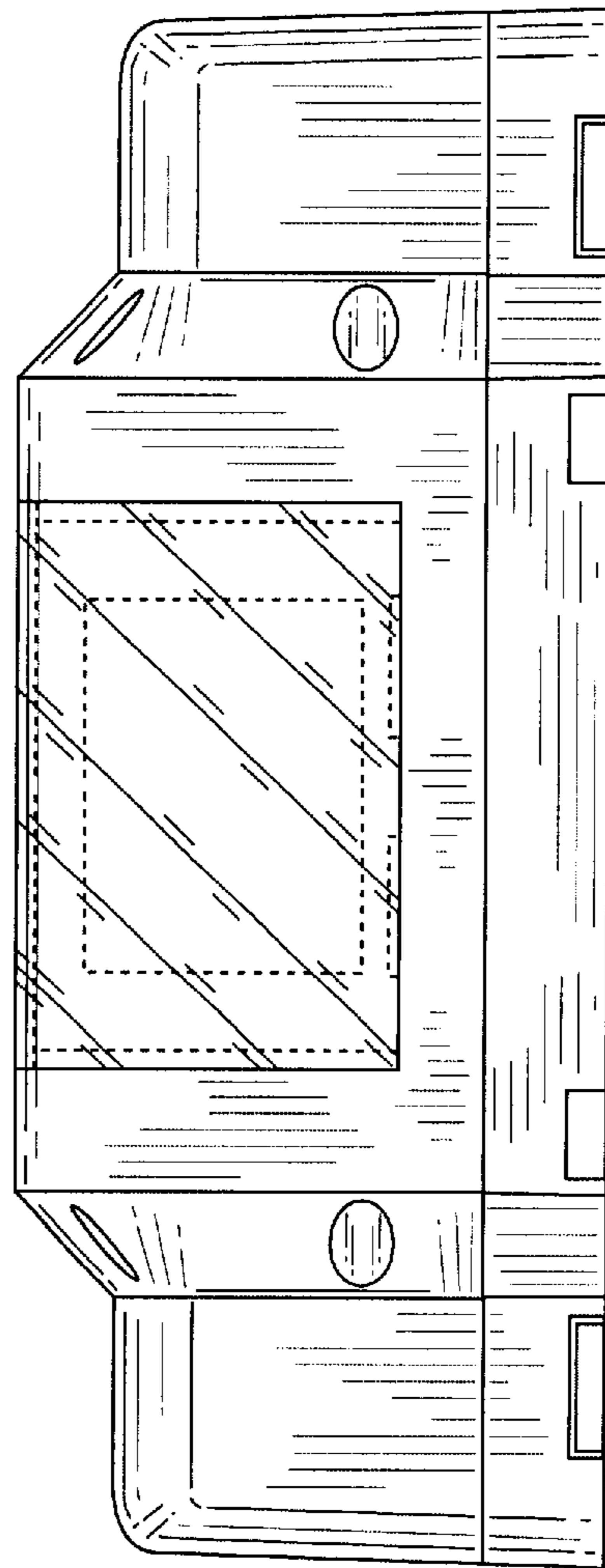
**FIG. 35**



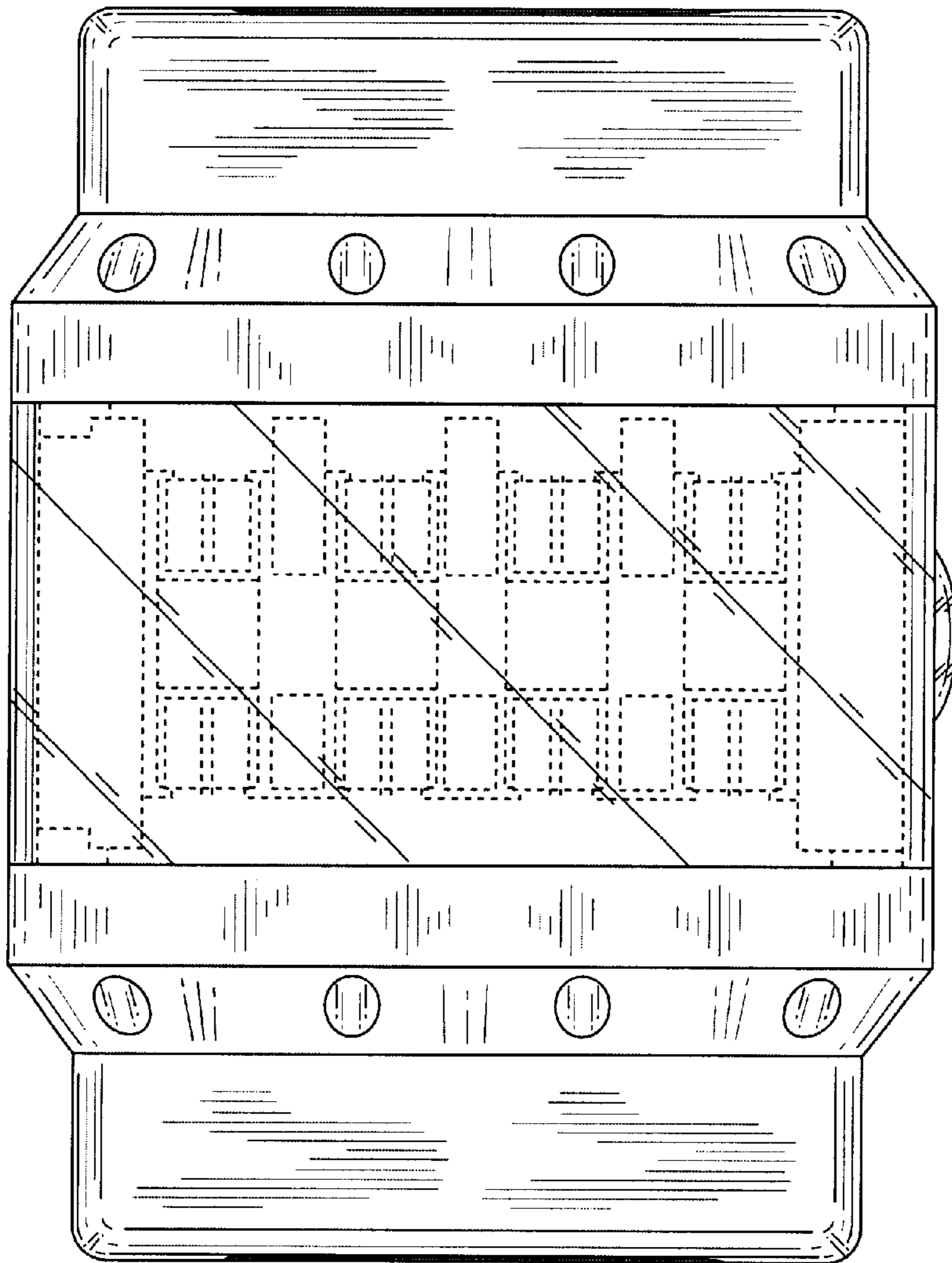
**FIG. 34**



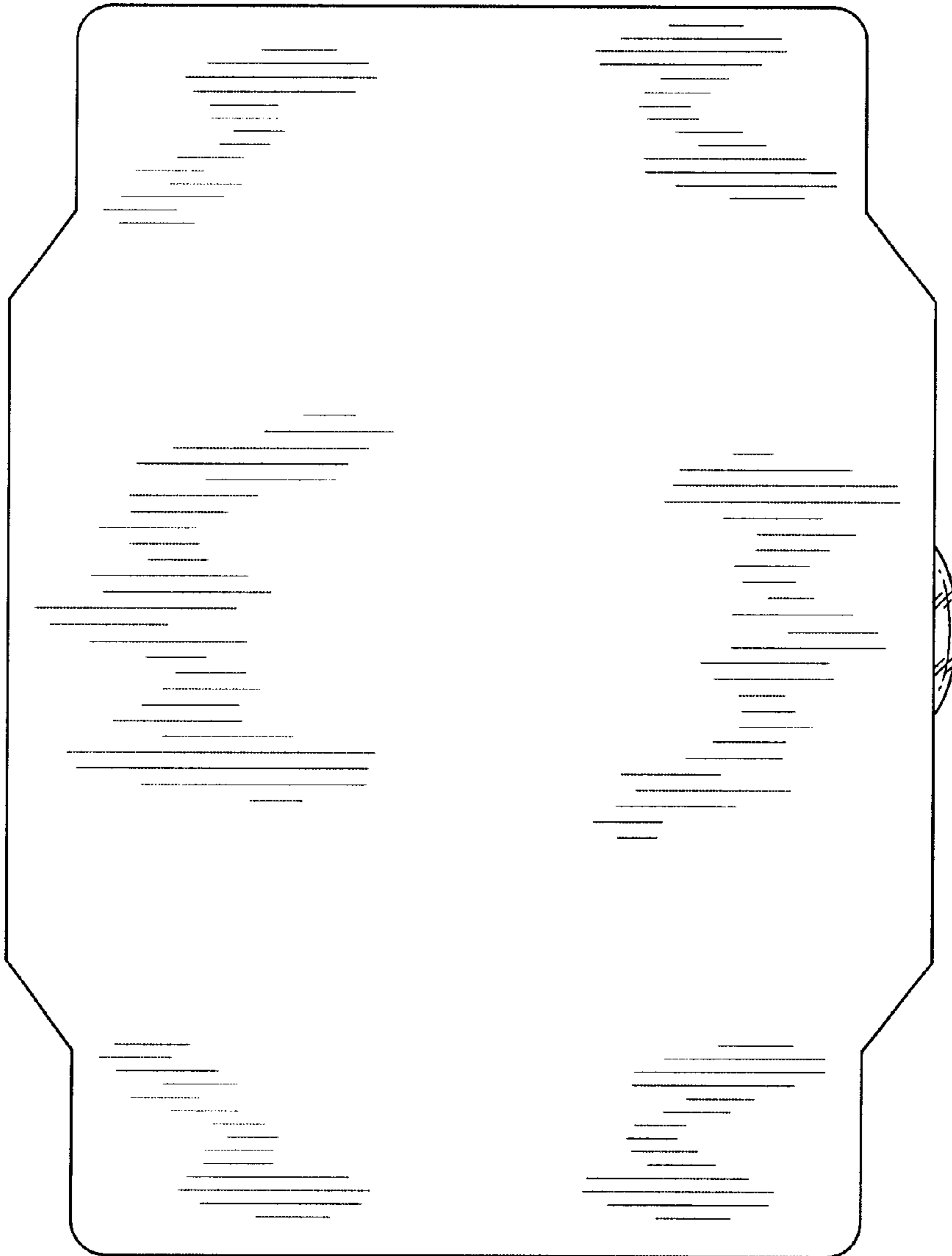
**FIG. 36**



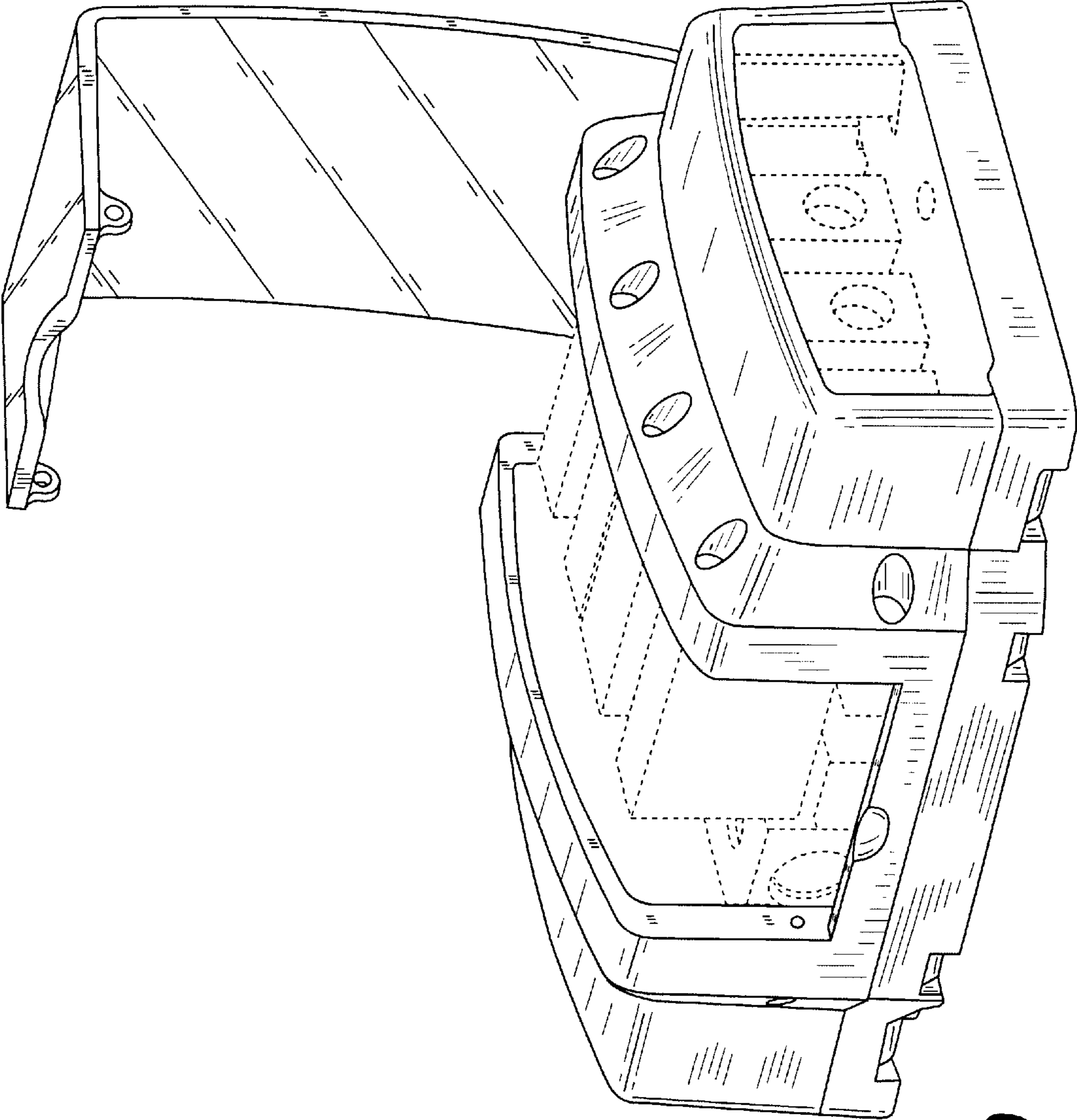
**FIG. 37**



**FIG. 38**



**FIG. 39**



**FIG. 40**