

US00D517976S

(12) **United States Design Patent**
Raatikainen

(10) **Patent No.:** **US D517,976 S**
(45) **Date of Patent:** **** Mar. 28, 2006**

(54) **TIRE**

6,439,286 B1 * 8/2002 Baumhofer et al. 152/209.8
D476,946 S * 7/2003 Lee et al. D12/524

(75) Inventor: **Jouni Raatikainen**, Lempäälä (FI)

OTHER PUBLICATIONS

(73) Assignee: **Nokian Tyres PLC**, Nokia (FI)

Marshal I'Zen KW15 Tire, 2003 Tread Design Guide, Jan. 2003, p. 37. 3/3.*

(**) Term: **14 Years**

* cited by examiner

(21) Appl. No.: **29/221,512**

Primary Examiner—Robert M. Spear

(22) Filed: **Jan. 18, 2005**

(74) *Attorney, Agent, or Firm*—Klauber & Jackson LLC

(30) **Foreign Application Priority Data**

(57) **CLAIM**

Oct. 8, 2004 (EM) 000244520

The ornamental design for tire, as shown.

(51) **LOC (8) Cl.** **12-15**

DESCRIPTION

(52) **U.S. Cl.** **D12/518; D12/524**

(58) **Field of Classification Search** D12/515,
D12/517, 518, 519, 520, 521, 522, 523, 524,
D12/531, 532; 152/209.1, 209.8, 209.9, 209.13,
152/455

FIG. 1 is a perspective view showing the tire of my new design;

FIG. 2 is a front view;

FIG. 3 is a back view;

FIG. 4 is a left side view;

FIG. 5 is a right side view; and,

FIG. 6 is an enlarged fragmentary front elevational view similar to that of FIG. 2, showing the tread pattern of the tire of my new design.

See application file for complete search history.

(56) **References Cited**

U.S. PATENT DOCUMENTS

D403,996 S * 1/1999 Espinasse et al. D12/524
D431,503 S * 10/2000 Cinquin D12/524

1 Claim, 6 Drawing Sheets

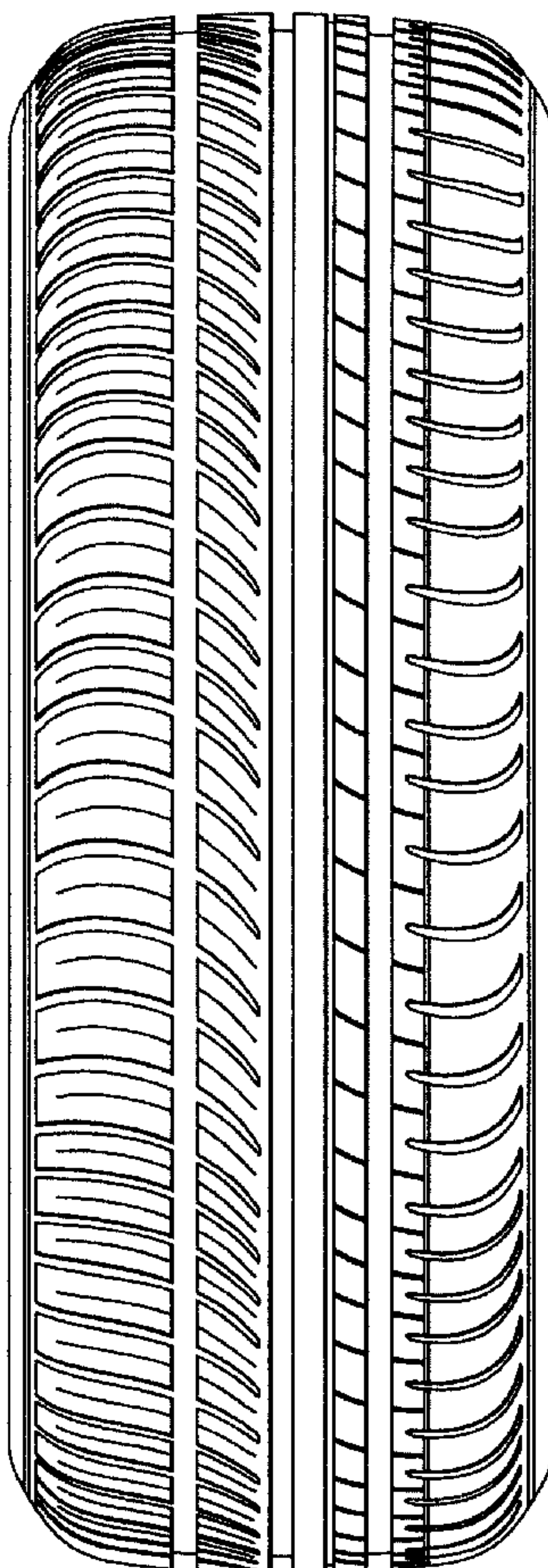

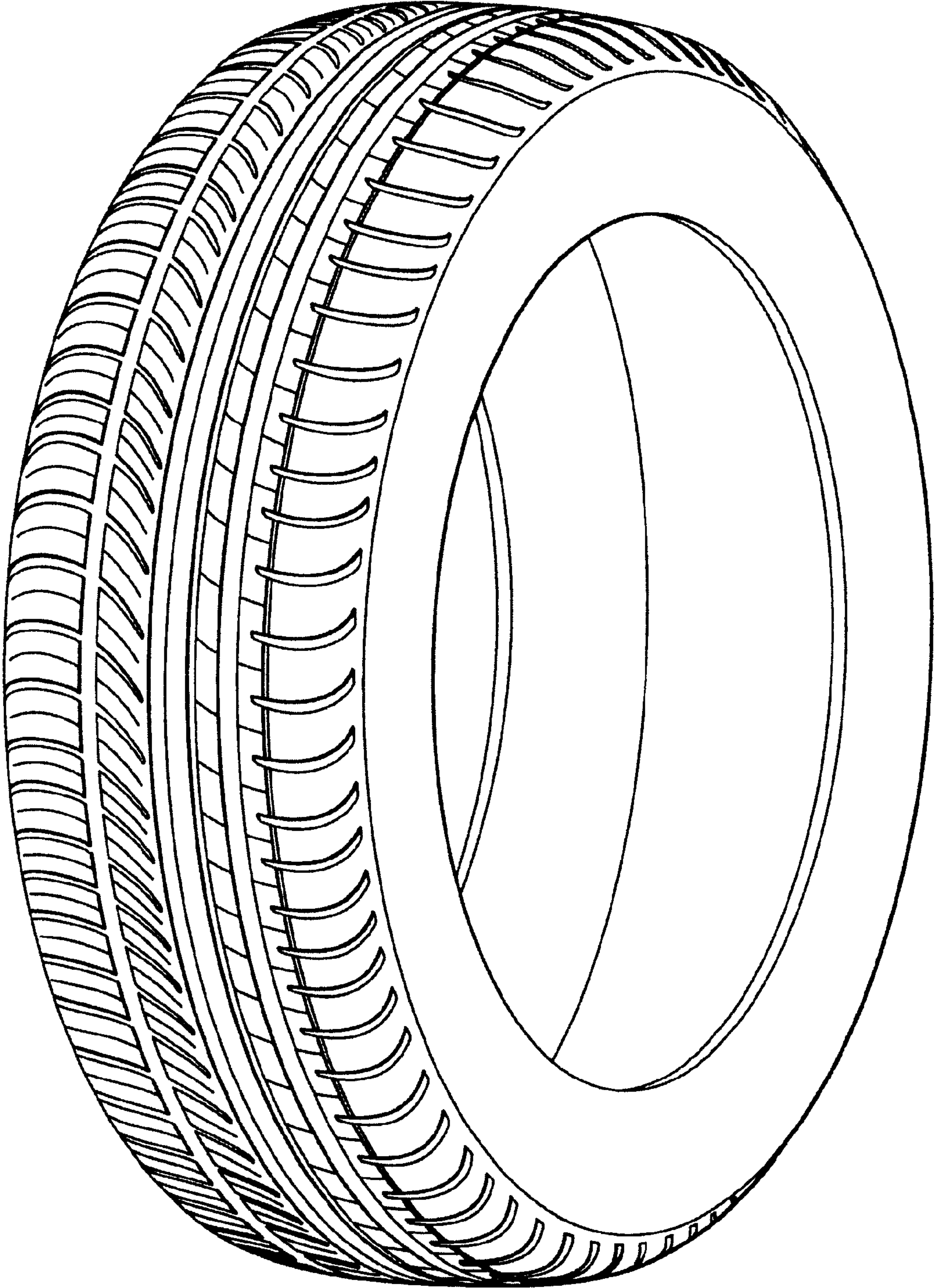

Fig. 1

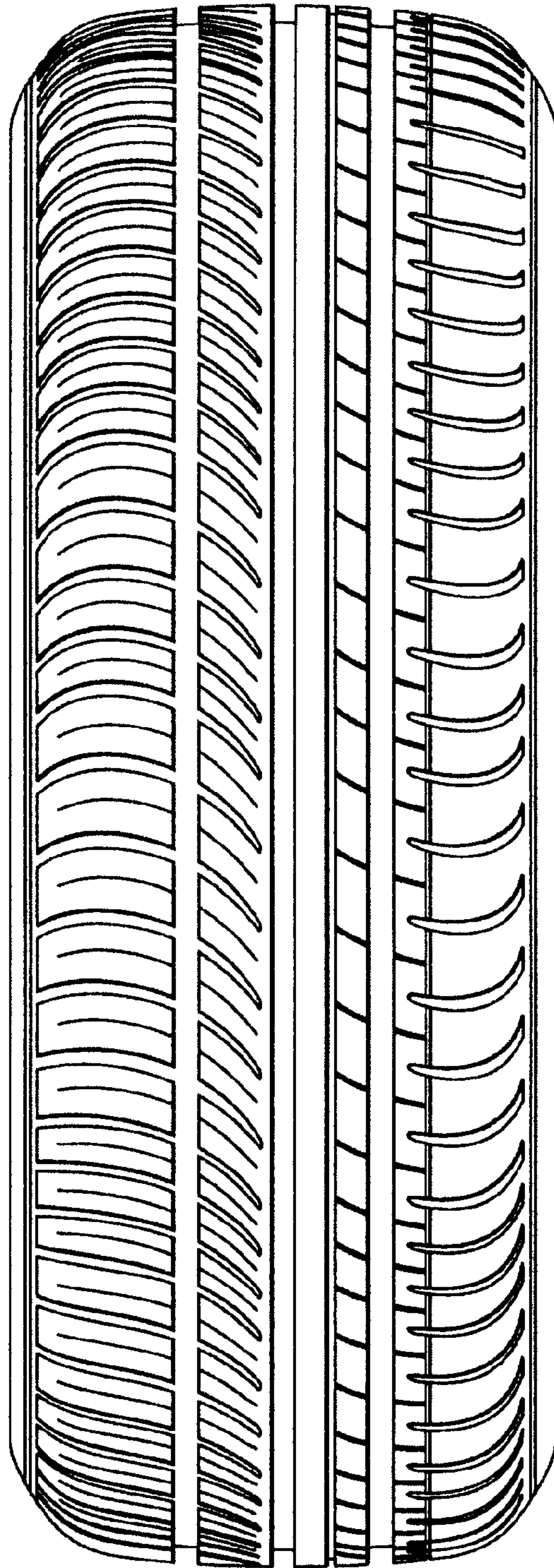

Fig. 2

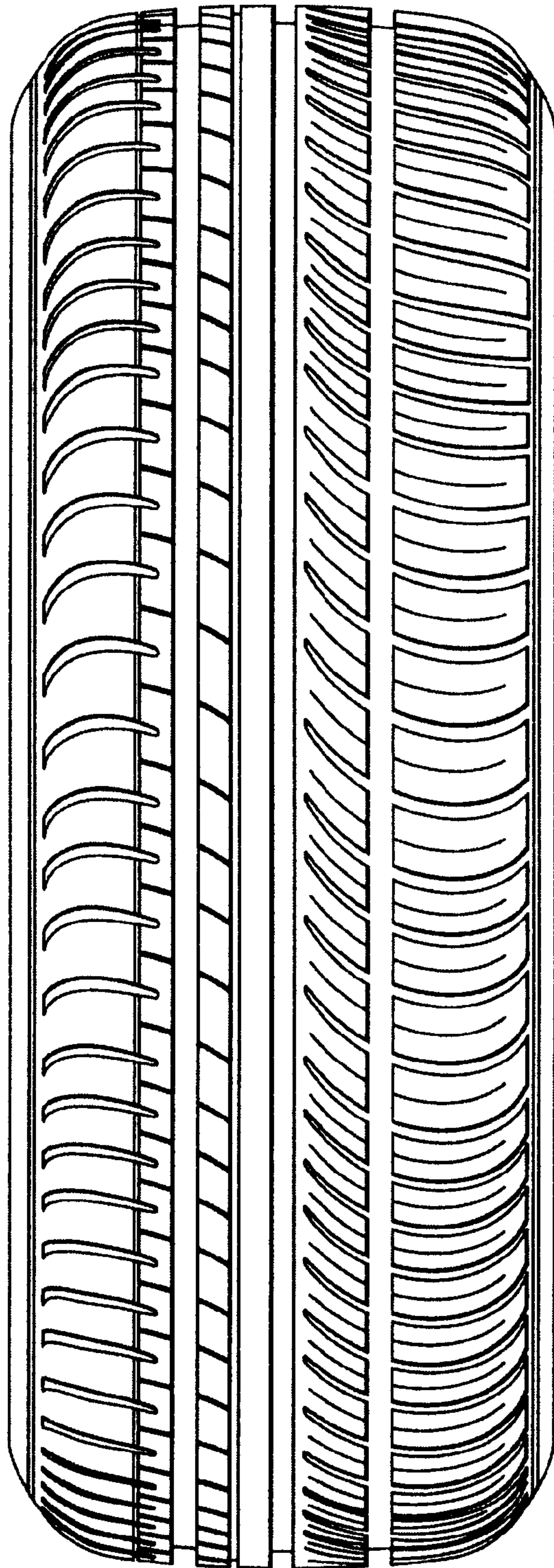

Fig. 3

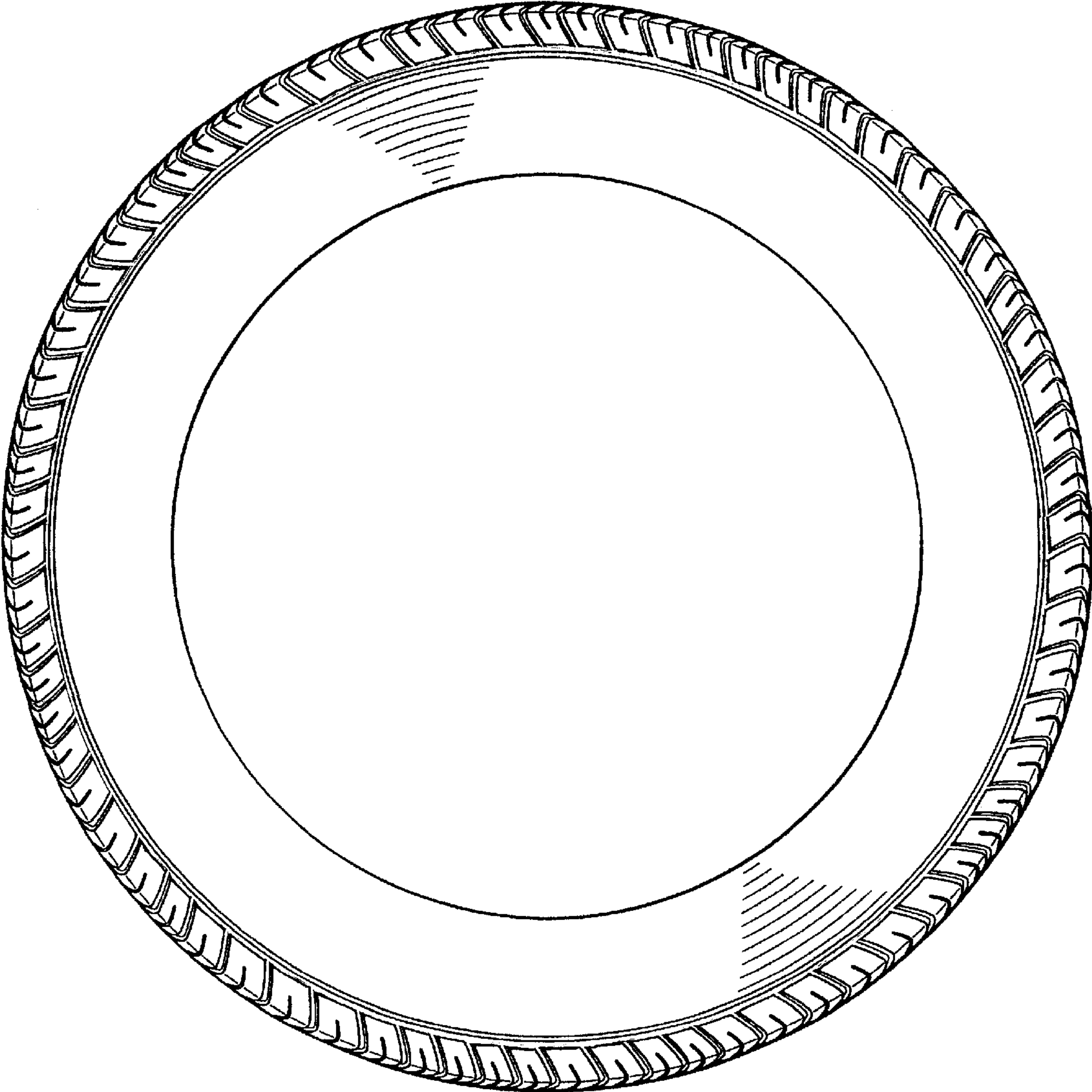

Fig. 4

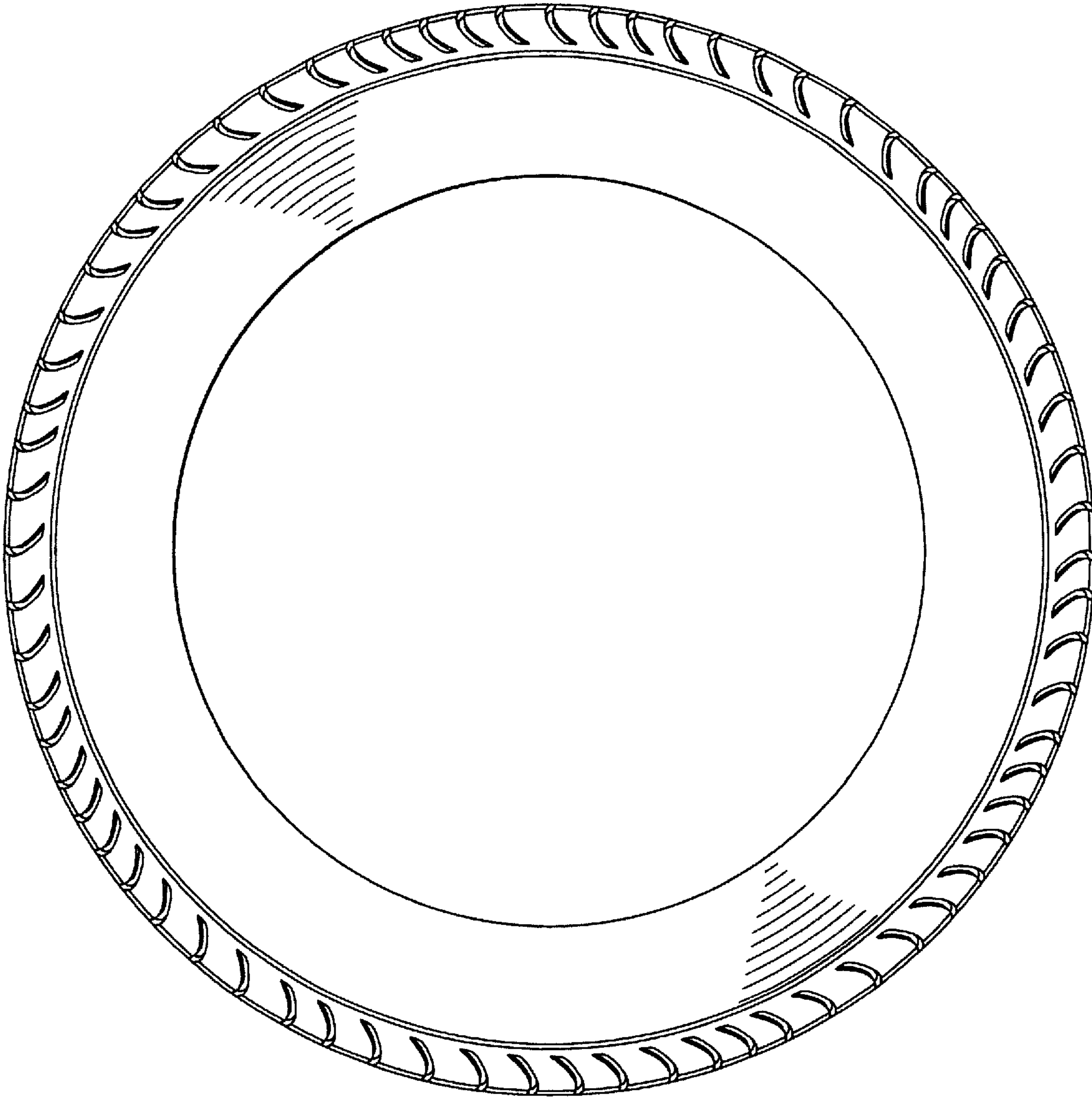

Fig. 5

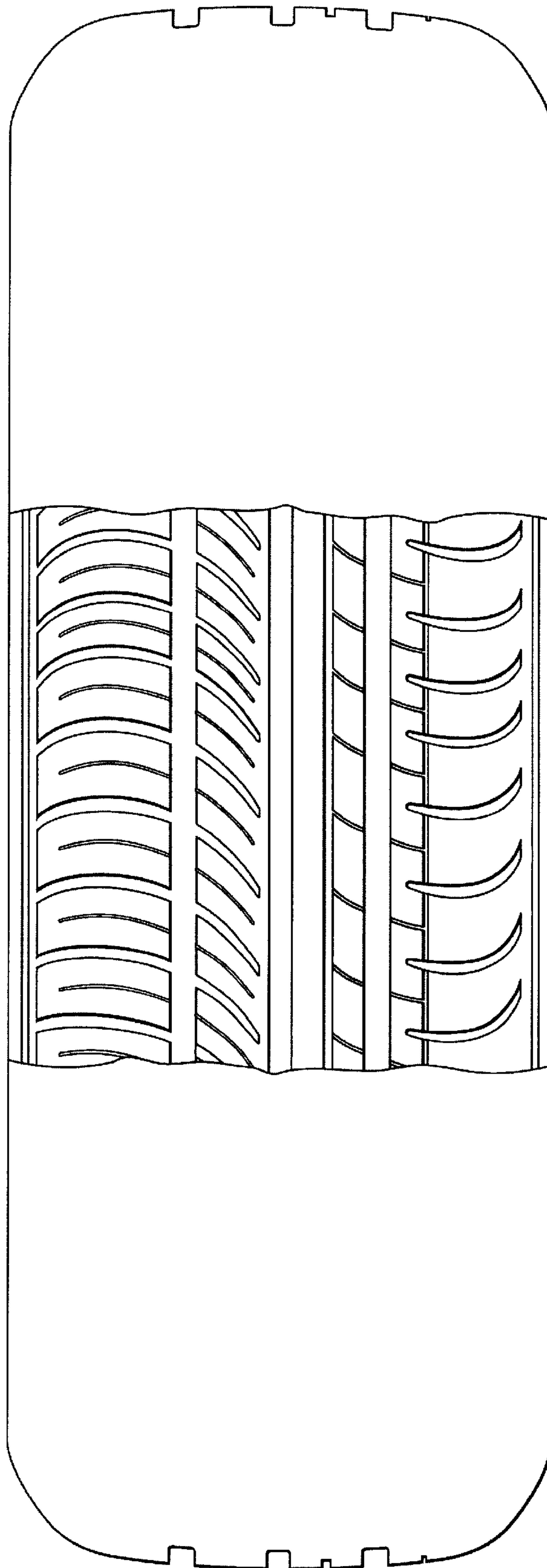

Fig. 6

UNITED STATES PATENT AND TRADEMARK OFFICE
CERTIFICATE OF CORRECTION

PATENT NO. : Des. 517,976 S
APPLICATION NO. : 29/221512
DATED : March 28, 2006
INVENTOR(S) : Jouni Raatikainen

Page 1 of 1

It is certified that error appears in the above-identified patent and that said Letters Patent is hereby corrected as shown below:

Title Page, item [54] in the title should read as follows: --TYRE--

Signed and Sealed this

Twenty-fifth Day of July, 2006

A handwritten signature in black ink on a light gray dotted background. The signature reads "Jon W. Dudas" in a cursive style.

JON W. DUDAS

Director of the United States Patent and Trademark Office