

US00D517632S

(12) **United States Design Patent**
Chen

(10) **Patent No.:** **US D517,632 S**
(45) **Date of Patent:** **** Mar. 21, 2006**

(54) **WHEEL**
(75) **Inventor:** **Ting-Hsing Chen, Tainan Hsien (TW)**
(73) **Assignee:** **Far Great Plastics Industrial Co., Ltd., Tainan Hsien (TW)**
(**) **Term:** **14 Years**
(21) **Appl. No.:** **29/225,043**
(22) **Filed:** **Mar. 11, 2005**

(51) **LOC (8) Cl.** **21-01**
(52) **U.S. Cl.** **D21/779; D21/563**
(58) **Field of Classification Search** **D21/423, D21/563, 779; 180/194; 280/836, 11.19, 280/11.221, 11.222, 11.226, 11.227, 11.24, 280/11.25, 29, 205; 301/5.1, 5.301, 95.101; 446/78, 95; D12/88, 500, 501, 604, 209; D8/8, 300, 307, 310, 358; D3/18, 24, 25; D22/137; D11/9, 11, 17; 63/37-39**
See application file for complete search history.

(56) **References Cited**

U.S. PATENT DOCUMENTS

698,110 A * 4/1902 Foy 301/5.301
817,739 A * 4/1906 Loepp 301/5.1
1,989,189 A * 1/1935 Frank 301/5.1
2,012,449 A * 8/1935 Hamilton 301/5.1
2,448,222 A * 8/1948 Jones 301/5.1
D179,220 S * 11/1956 Russell D8/310
3,355,185 A * 11/1967 Carter 280/11.226
D282,838 S * 3/1986 McCarthy D13/179
D299,773 S * 2/1989 Kracke D34/7
4,844,492 A * 7/1989 Ludwig 280/11.227
D361,492 S * 8/1995 Chieda D8/310
D390,624 S * 2/1998 Yamaguchi D22/137
D396,179 S * 7/1998 Burns et al. D8/310
D401,834 S * 12/1998 Burns et al. D8/310
D409,712 S * 5/1999 Kobayashi D22/137

D410,991 S * 6/1999 Miyazaki D22/137
D414,220 S * 9/1999 Catto D21/423
D425,963 S * 5/2000 Kobayashi D22/137
D429,455 S * 8/2000 Burns et al. D8/310
D443,000 S * 5/2001 Chen D21/423
D453,466 S * 2/2002 Dewald et al. D8/310
D465,975 S * 11/2002 Iacona D8/8
D468,190 S * 1/2003 Kennedy et al. D8/358
D472,603 S * 4/2003 Shepler et al. D22/137
D493,128 S * 7/2004 Waters et al. D12/174
2002/0020975 A1 * 2/2002 Dahan 280/11.221

OTHER PUBLICATIONS

www.insulators.com, Jan. 16, 2003, [online], [retrieved on Jul. 29, 2005] Retrieved from search using Internet Archive—Wayback Machine <URL:http://web.archive.org/web/20030116171943/http://www.insulators.com/porcelain/photos/photos/blu-spool.htm>.*

* cited by examiner

Primary Examiner—Antoine Duval Davis
Assistant Examiner—Cynthia M. Chin
(74) *Attorney, Agent, or Firm*—Rosenberg, Klein & Lee

(57) **CLAIM**

I claim, the ornamental design for a wheel, as shown and described.

DESCRIPTION

FIG. 1 is a perspective view of a wheel showing my present design;
FIG. 2 is a front view thereof;
FIG. 3 is a rear view thereof;
FIG. 4 is a left view thereof;
FIG. 5 is a right view thereof;
FIG. 6 is a top plan view thereof; and,
FIG. 7 is a bottom plan view.

1 Claim, 5 Drawing Sheets

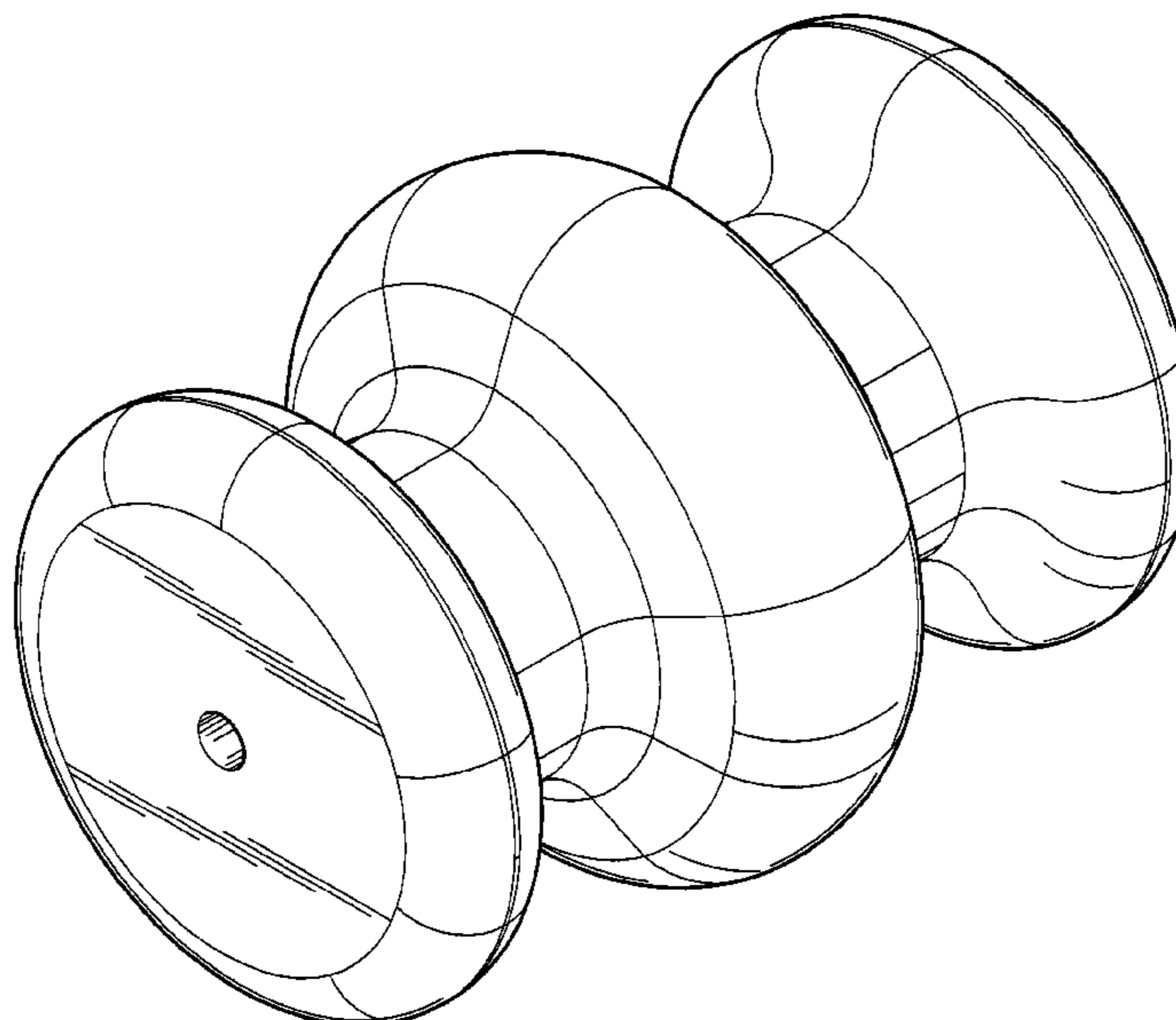

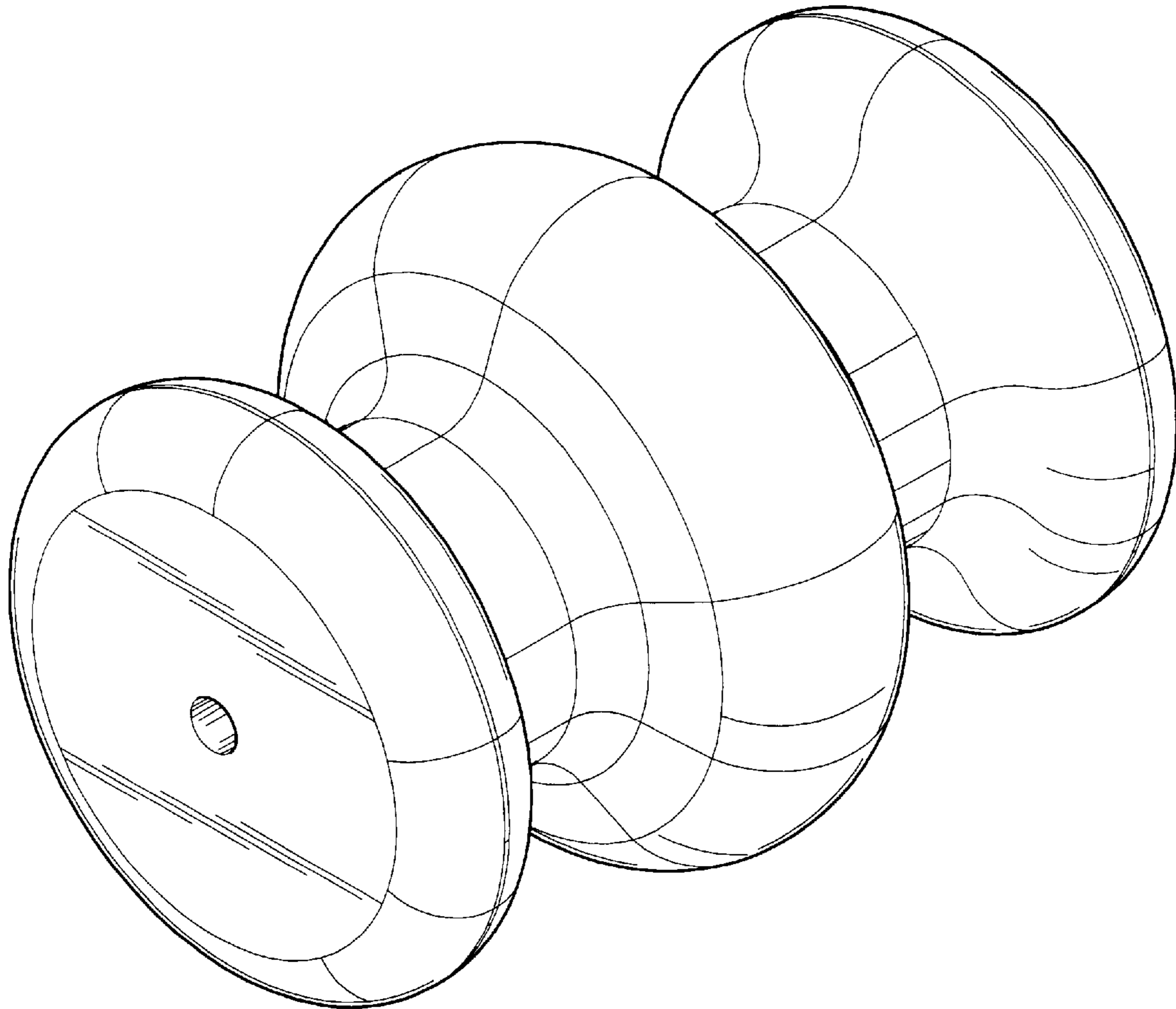

FIG. 1

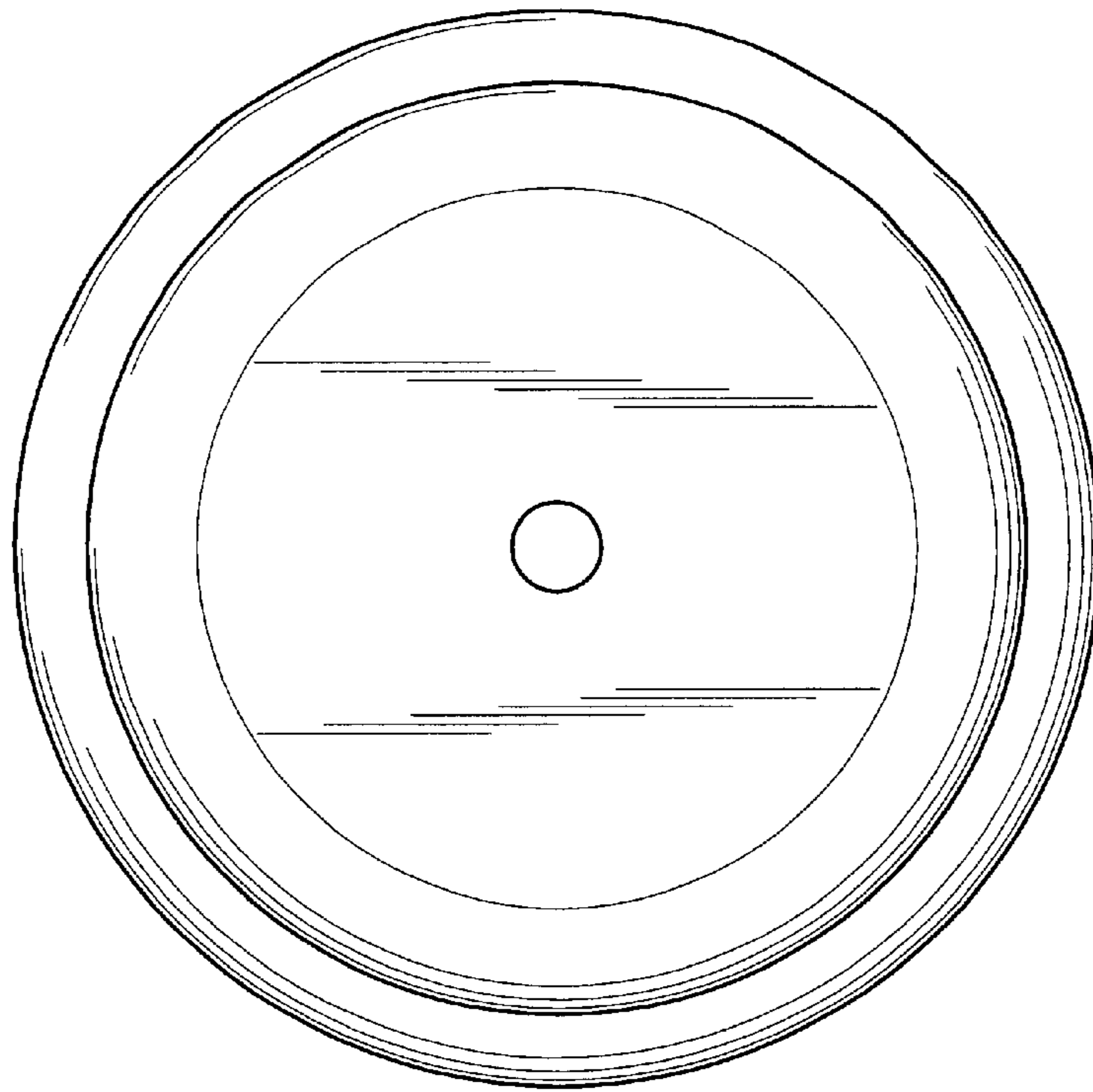

FIG. 2

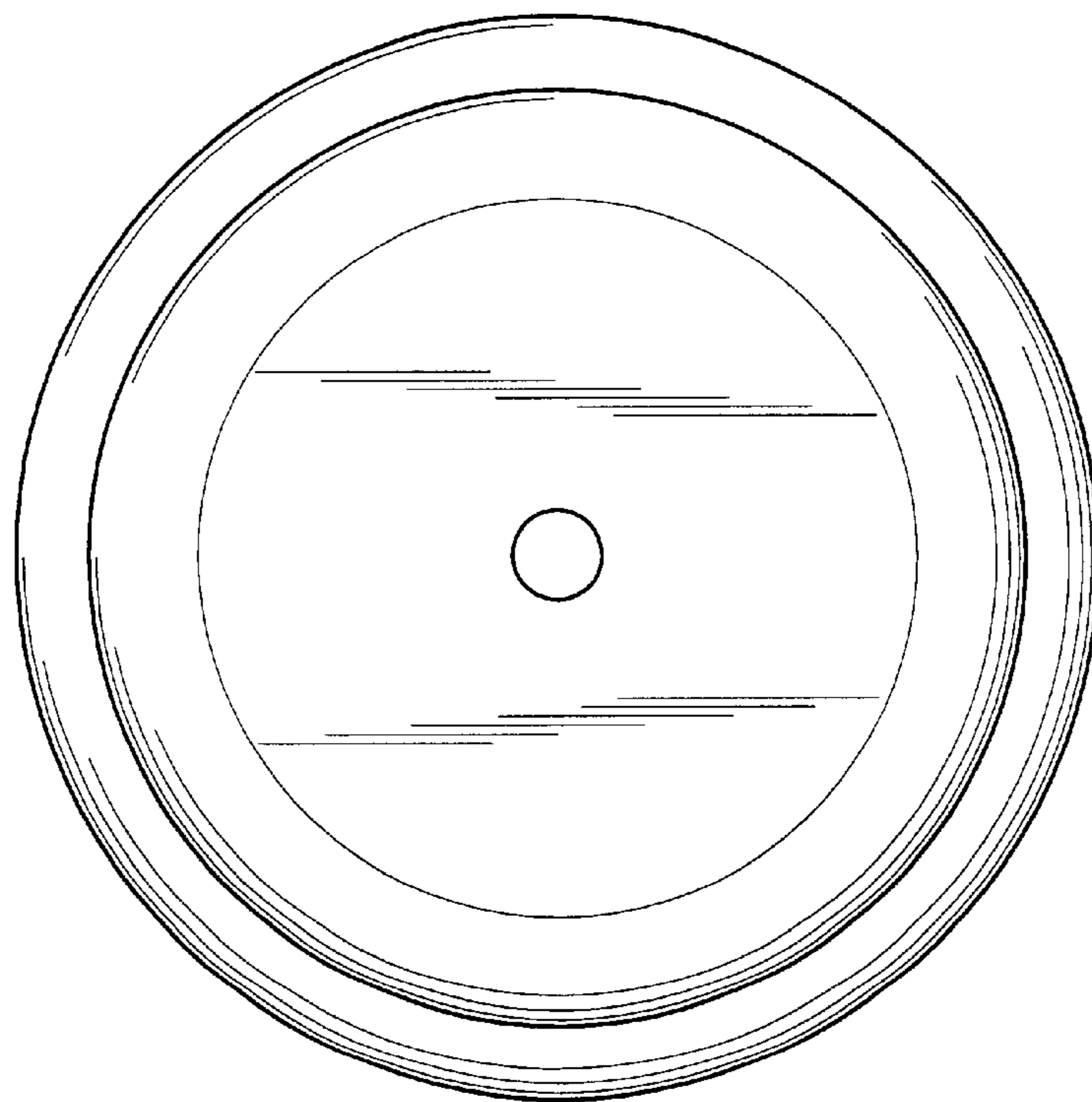

FIG. 3

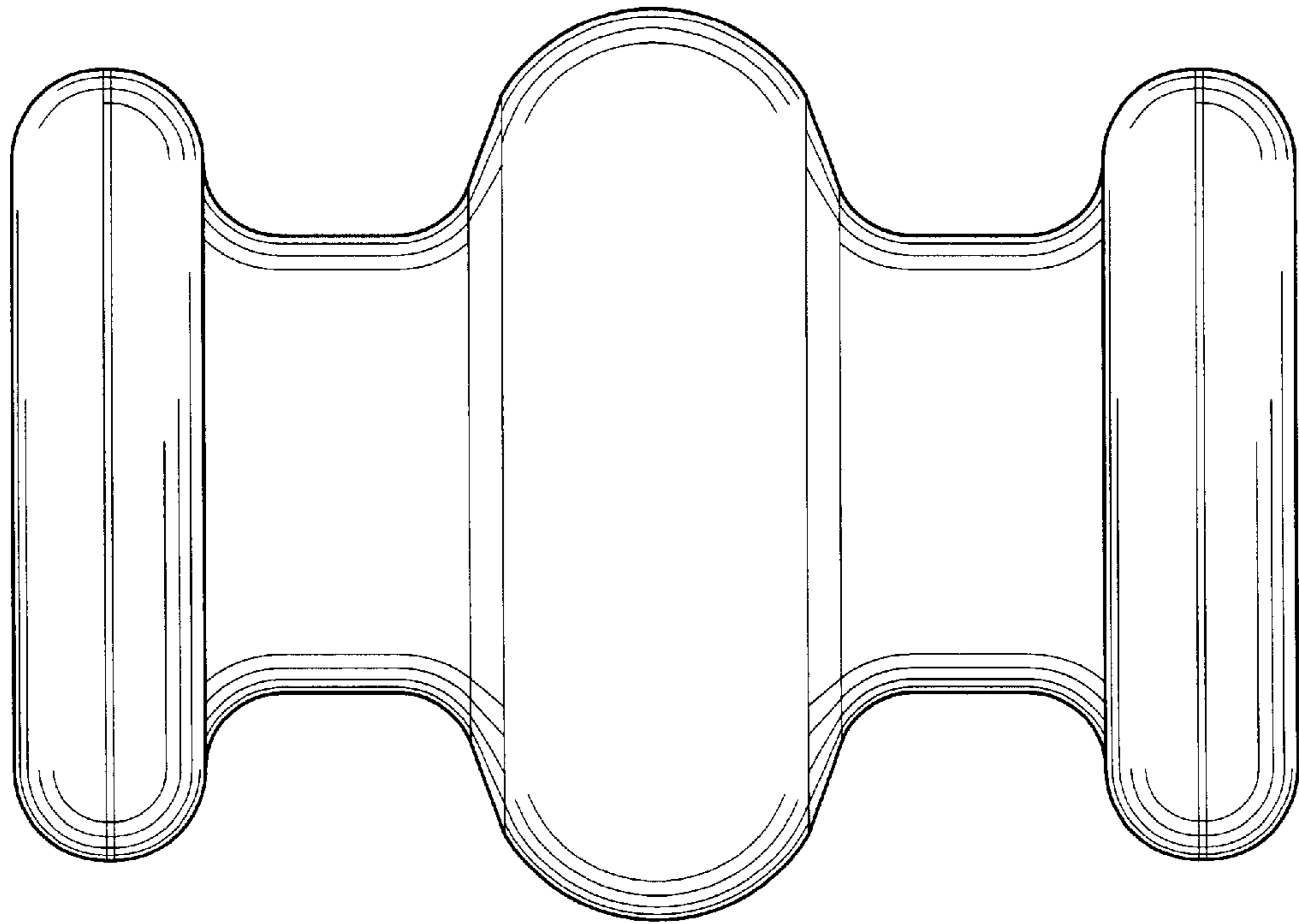

FIG. 4

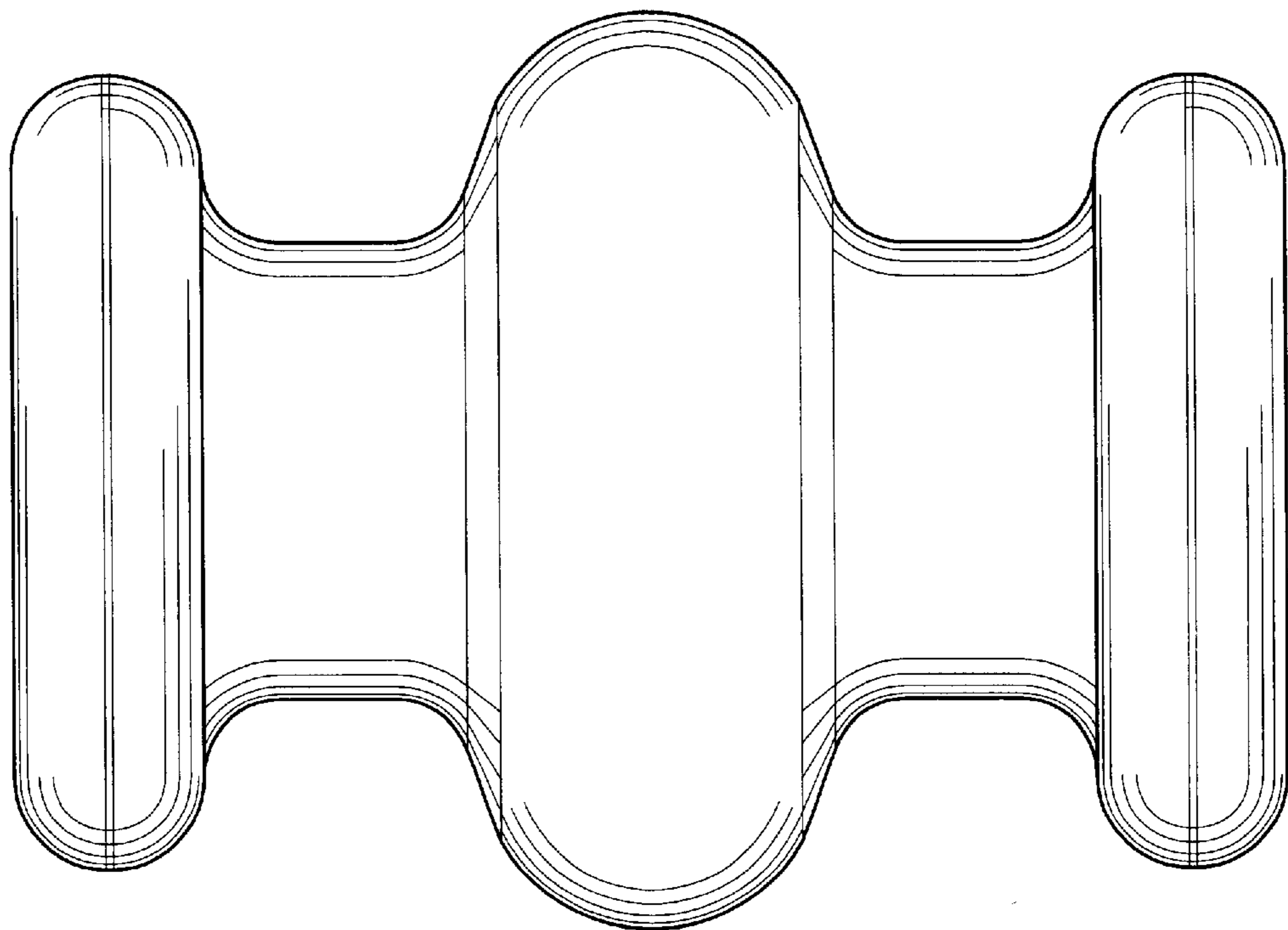

FIG. 5

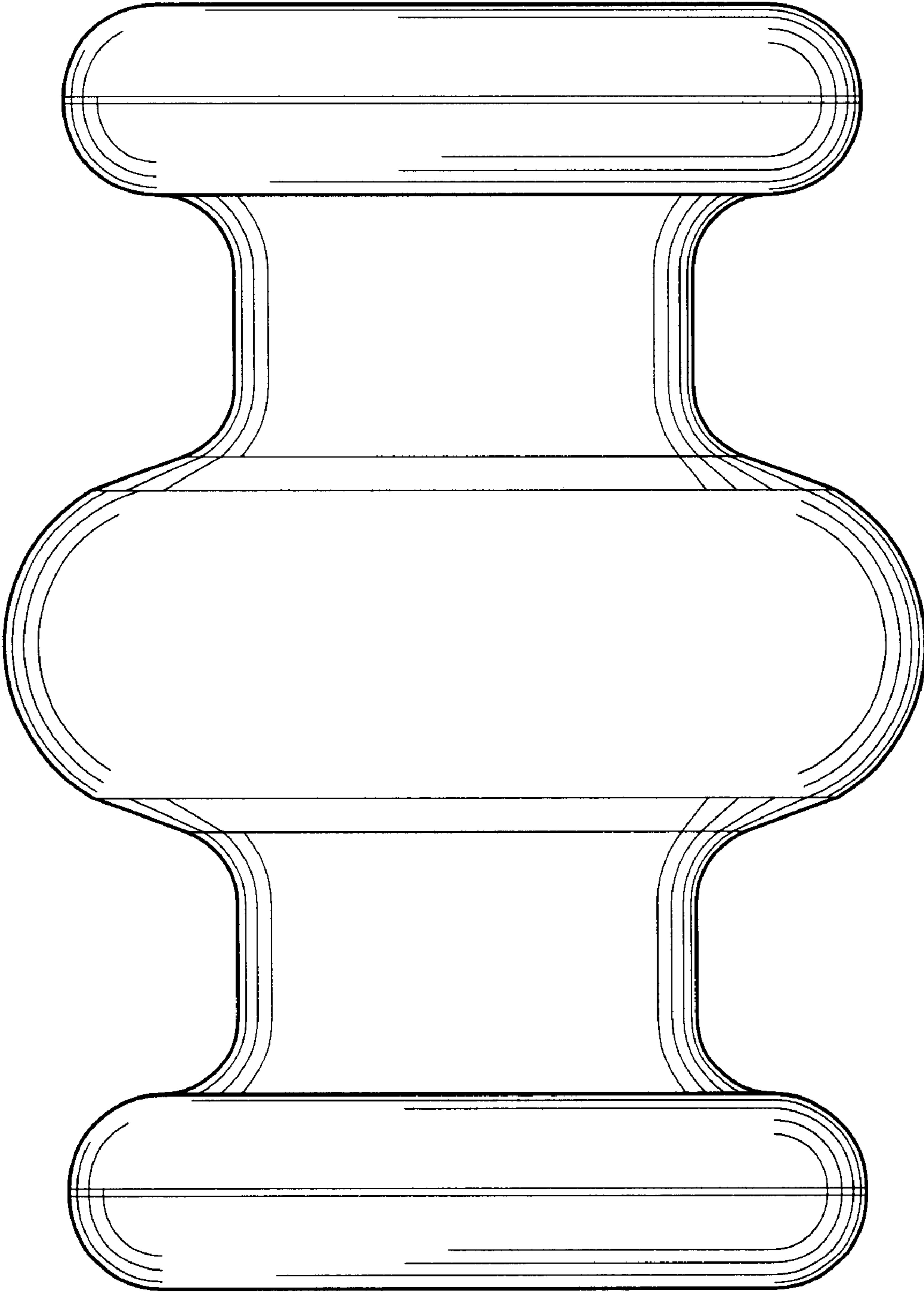

FIG. 6

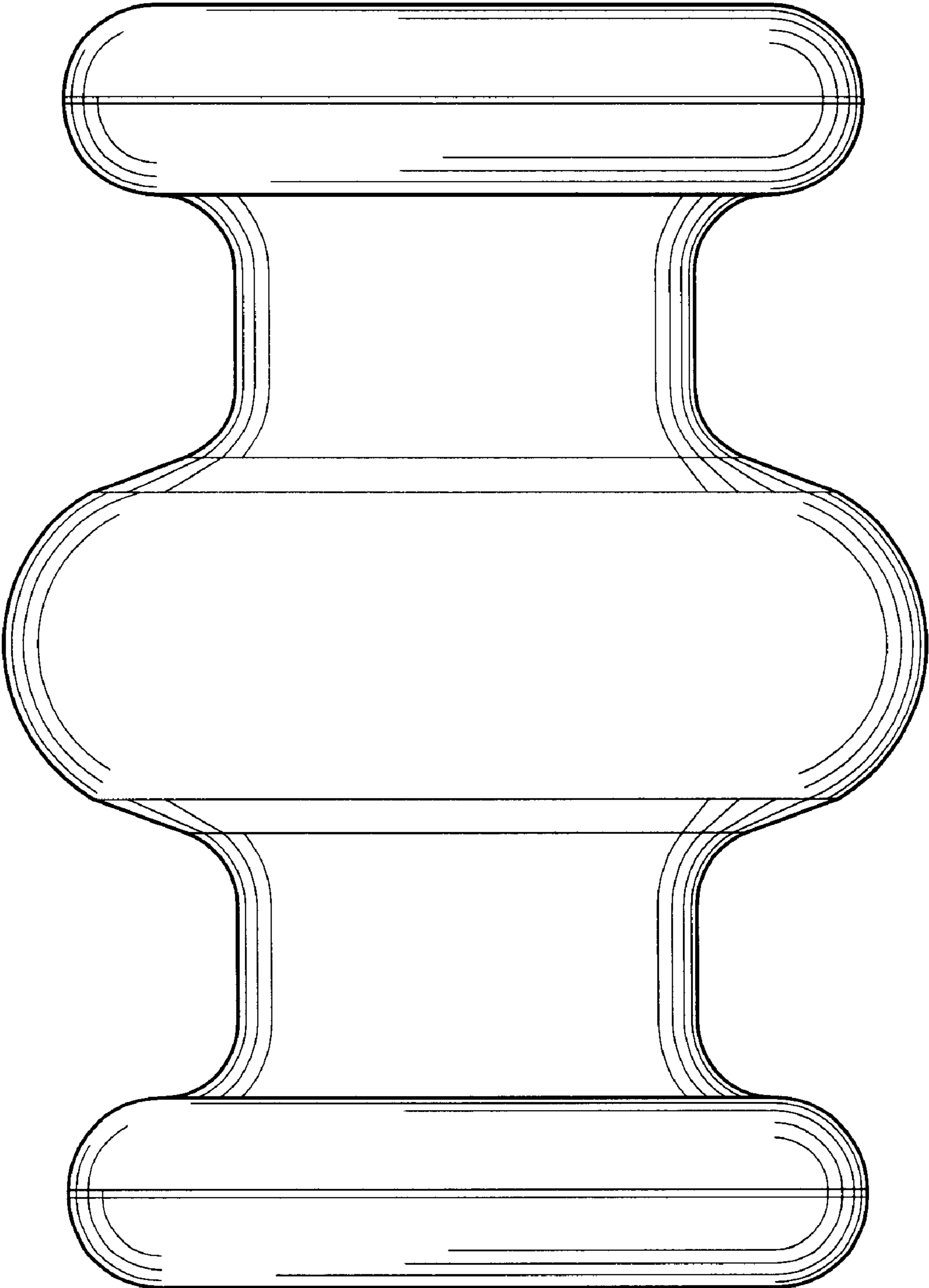

FIG. 7