



US00D517505S

(12) **United States Design Patent** (10) **Patent No.:** **US D517,505 S**
Disbennett et al. (45) **Date of Patent:** **** Mar. 21, 2006**

(54) **SINGLE FUSE HOLDER**
 (75) Inventors: **Scott Disbennett**, Lake Mary, FL (US);
Edward T. Robertson, Port Orange, FL
 (US); **John C. Williams**, Covina, CA
 (US); **William Lauer**, Ormond Beach,
 FL (US)

(73) Assignee: **Metra Electronics Corporation**, Holly
 Hill, FL (US)

(**) Term: **14 Years**

(21) Appl. No.: **29/222,530**

(22) Filed: **Feb. 2, 2005**

(51) **LOC (8) Cl.** **13-03**

(52) **U.S. Cl.** **D13/178**; D13/161

(58) **Field of Classification Search** D13/160,
 D13/161, 178; 337/181, 186, 196, 199, 205,
 337/213; 361/600, 626, 642, 646, 833, 834,
 361/809, 835; 439/76.12, 621, 622, 698,
 439/830, 831, 832

See application file for complete search history.

(56) **References Cited**

U.S. PATENT DOCUMENTS

5,002,505	A	3/1991	Jones et al.	439/622
5,167,541	A *	12/1992	Alves et al.	439/622
5,594,403	A *	1/1997	Taga et al.	337/186
5,618,209	A	4/1997	Lin et al.	439/621
D381,010	S	7/1997	Ansley	D13/178
5,648,749	A	7/1997	Lin et al.	337/205
D390,831	S	2/1998	Liang	D13/178
D406,111	S *	2/1999	Awbrey	D13/178
6,004,159	A	12/1999	Liang	439/621
6,162,097	A	12/2000	Liang	439/621
6,326,878	B1	12/2001	Liang	337/215

D460,742	S *	7/2002	Iby et al.	D13/161
D460,949	S *	7/2002	Iby et al.	D13/161
6,551,141	B1	4/2003	Liang	439/621
D490,381	S *	5/2004	Dejan	D13/178
6,753,754	B1 *	6/2004	Black et al.	337/215
2001/0035819	A1	11/2001	Tsai	340/439

OTHER PUBLICATIONS

2003 Tsunami Premium Installation Accessories Catalog,
 Pgs. Cover, 25, Published Feb., 2003.

2004 Tsunami Premium Installation Accessories Catalog,
 Pgs. Cover, 29–30, Published Feb., 2004.

2003 Raptor Installation Accessories Catalog, Pgs. Cover,
 12–15, Published Feb., 2003.

* cited by examiner

Primary Examiner—Stella Reid

Assistant Examiner—Selina Sikder

(74) *Attorney, Agent, or Firm*—Fitzpatrick, Cella, Harper &
 Scinto

(57) **CLAIM**

We claim the ornamental design for a single fuse holder, as
 shown and described.

DESCRIPTION

FIG. 1 is a left-front perspective view of a single fuse holder
 showing a preferred embodiment of our new design;

FIG. 2 is a top plan view of FIG. 1;

FIG. 3 is a bottom plan view of FIG. 1;

FIG. 4 is a left side elevation of FIG. 1. The right side is a
 mirror image thereof;

FIG. 5 is a front elevation of FIG. 1; and,

FIG. 6 is a rear elevation of FIG. 1.

The broken line showing of the environment is for illustra-
 tive purpose only and forms no part of the claimed design.

1 Claim, 4 Drawing Sheets

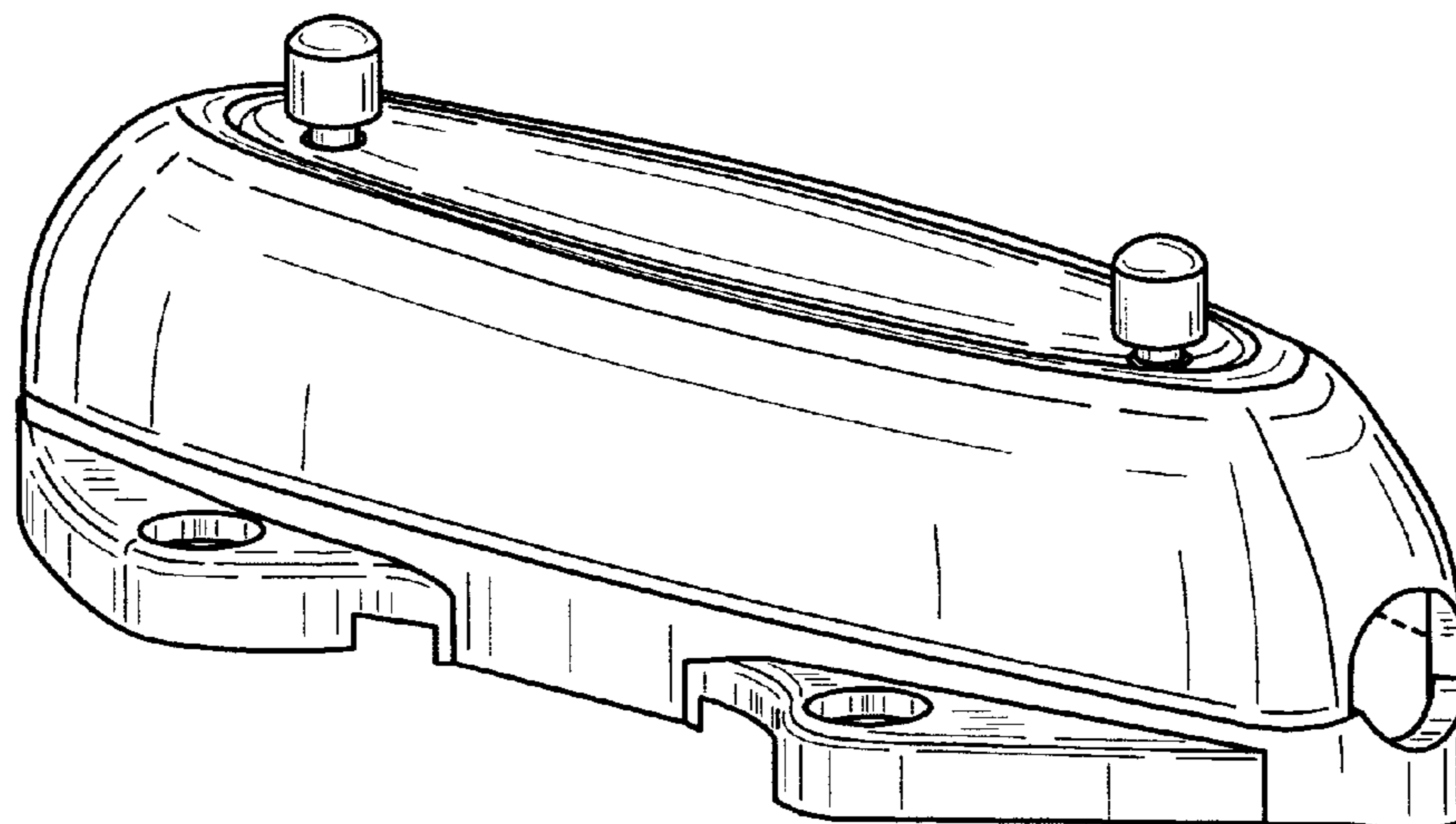

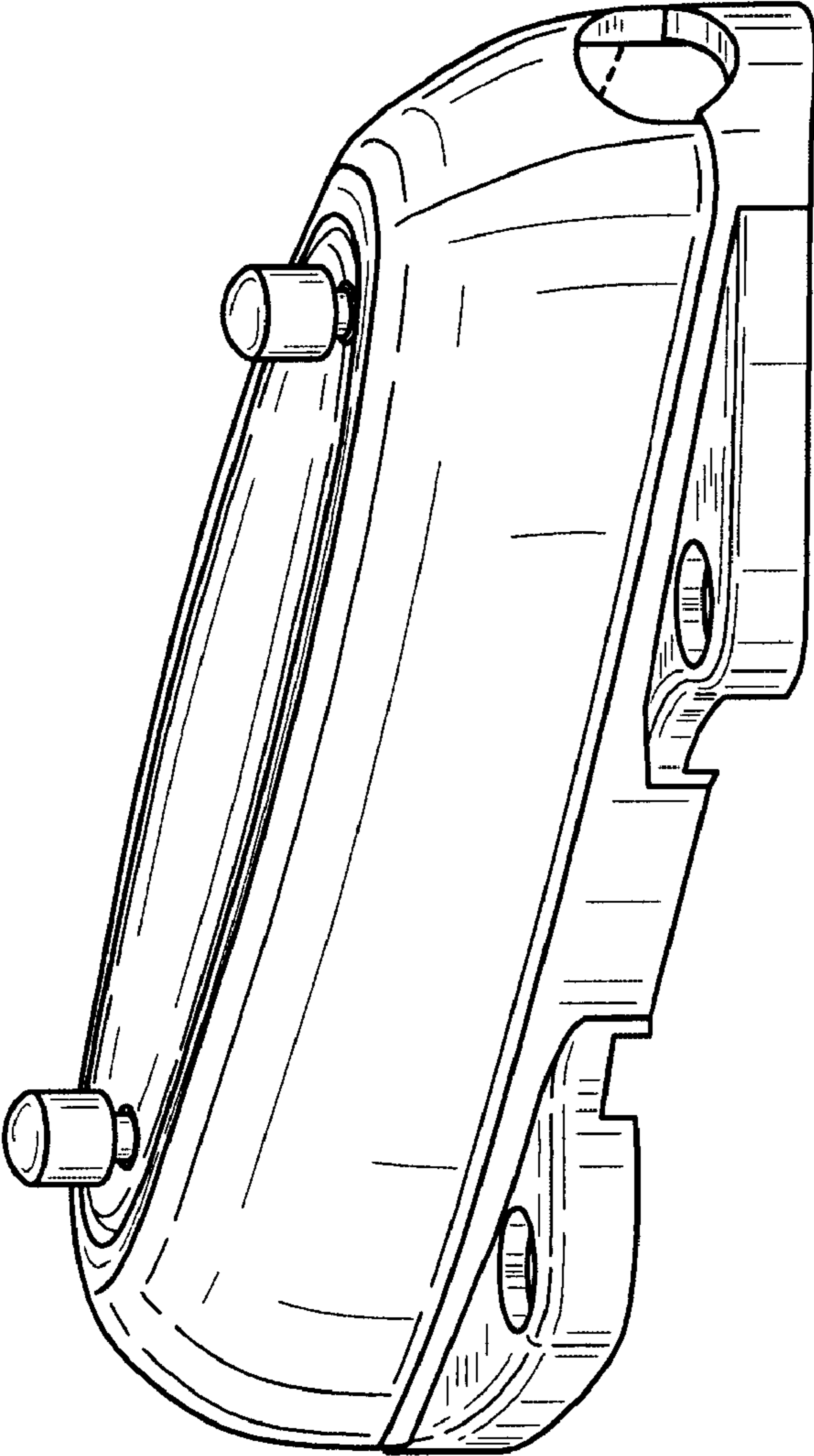

FIG. 1

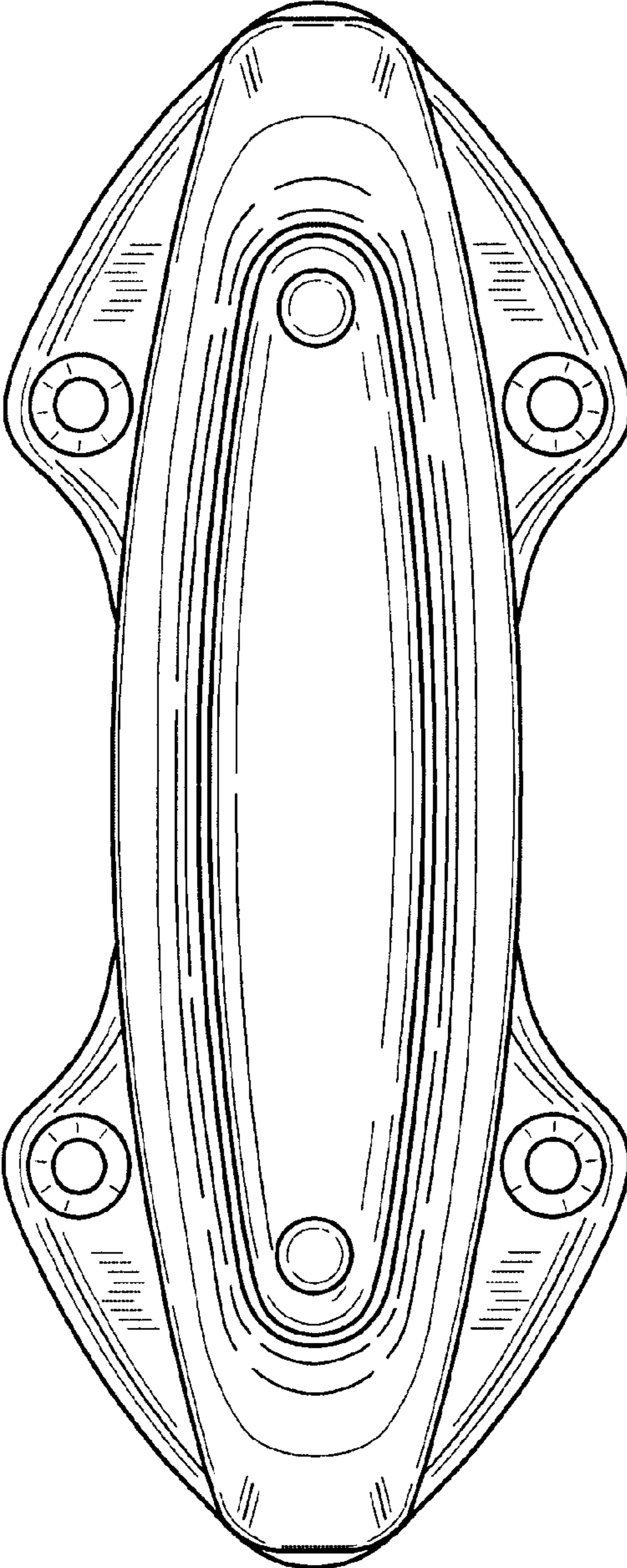

FIG. 2

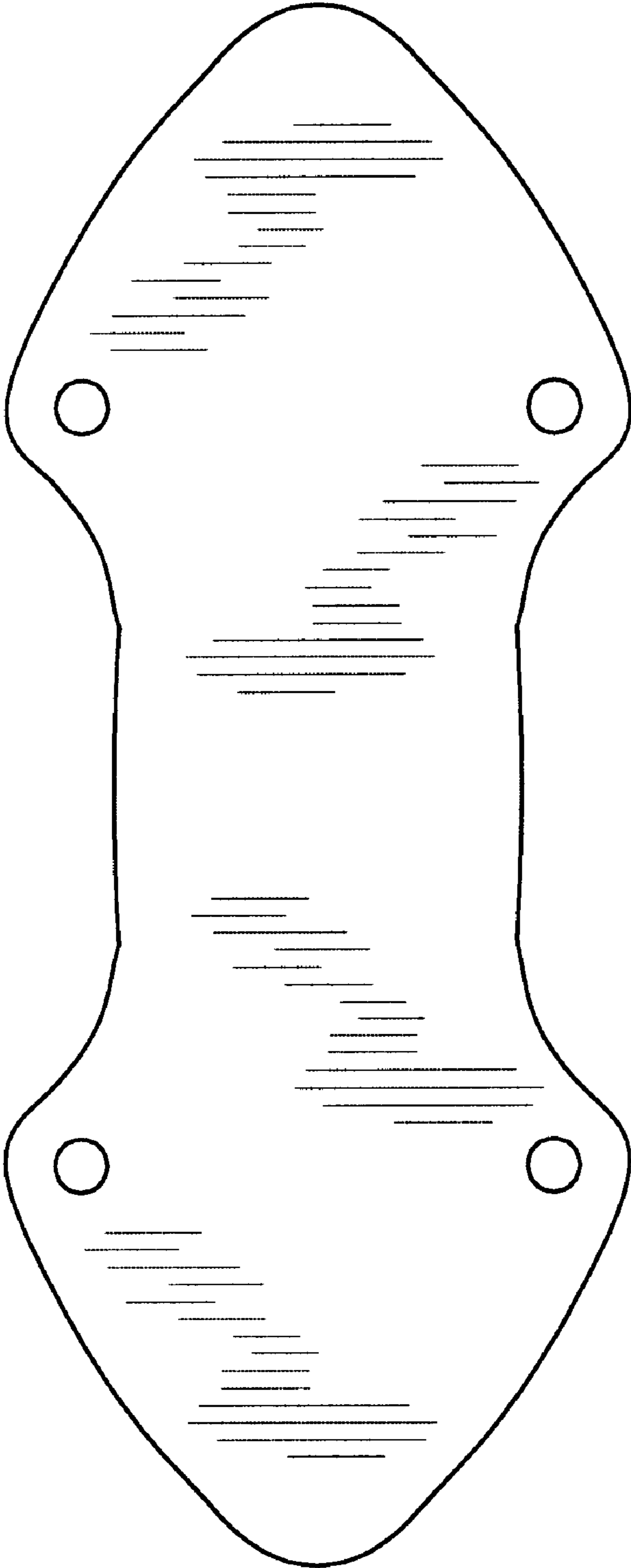

FIG. 3

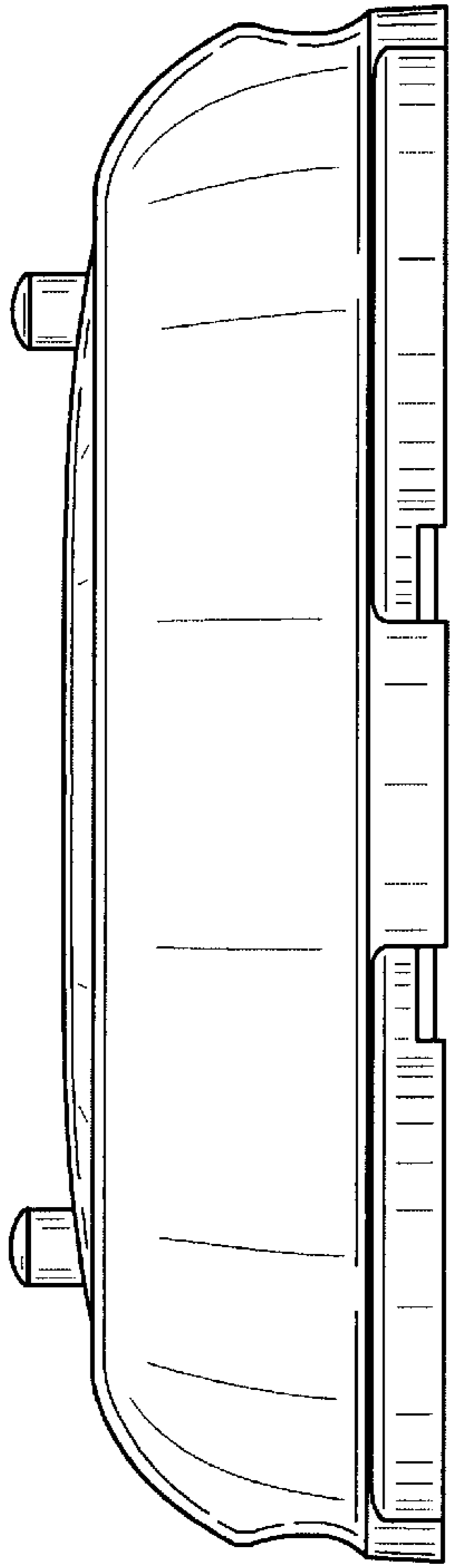

FIG. 4

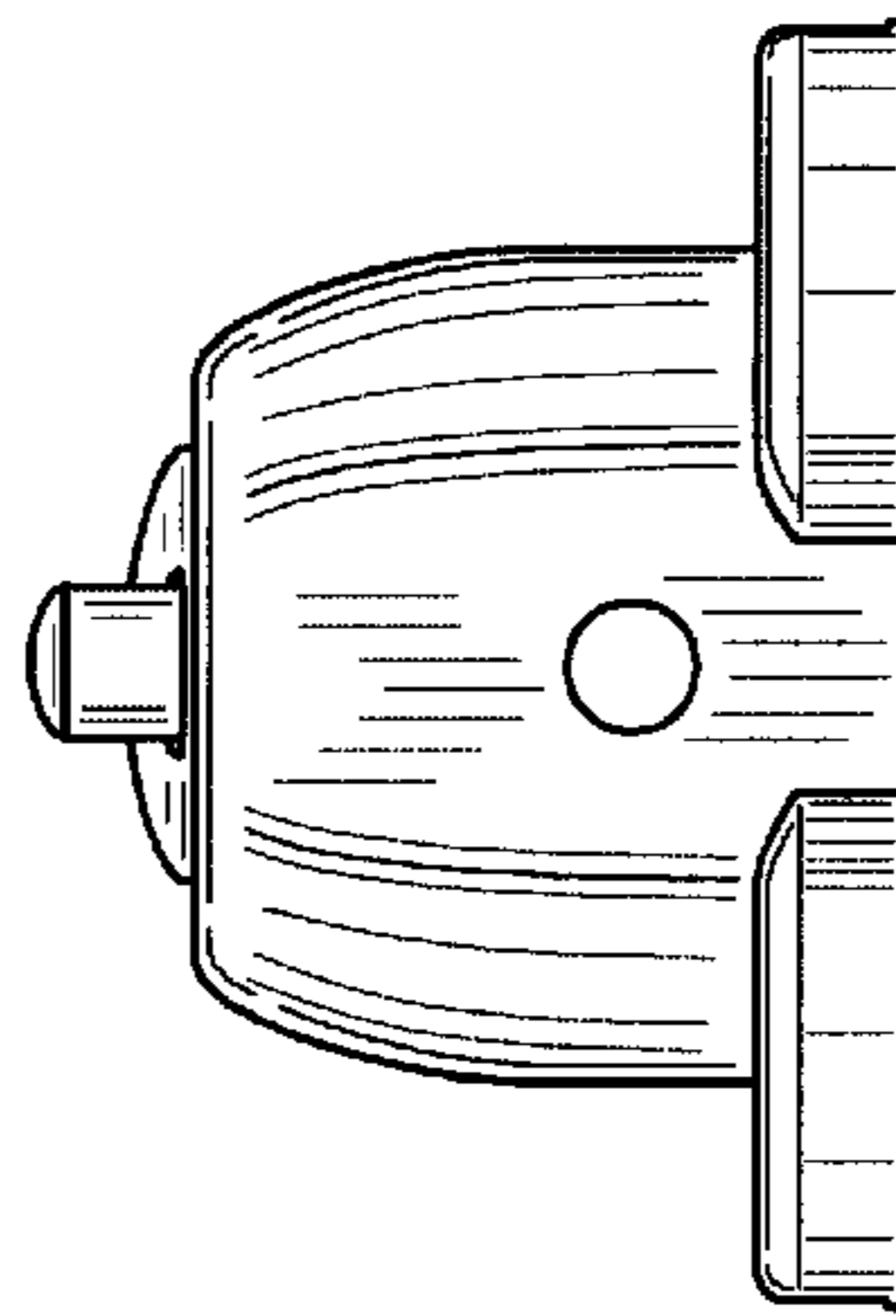

FIG. 5

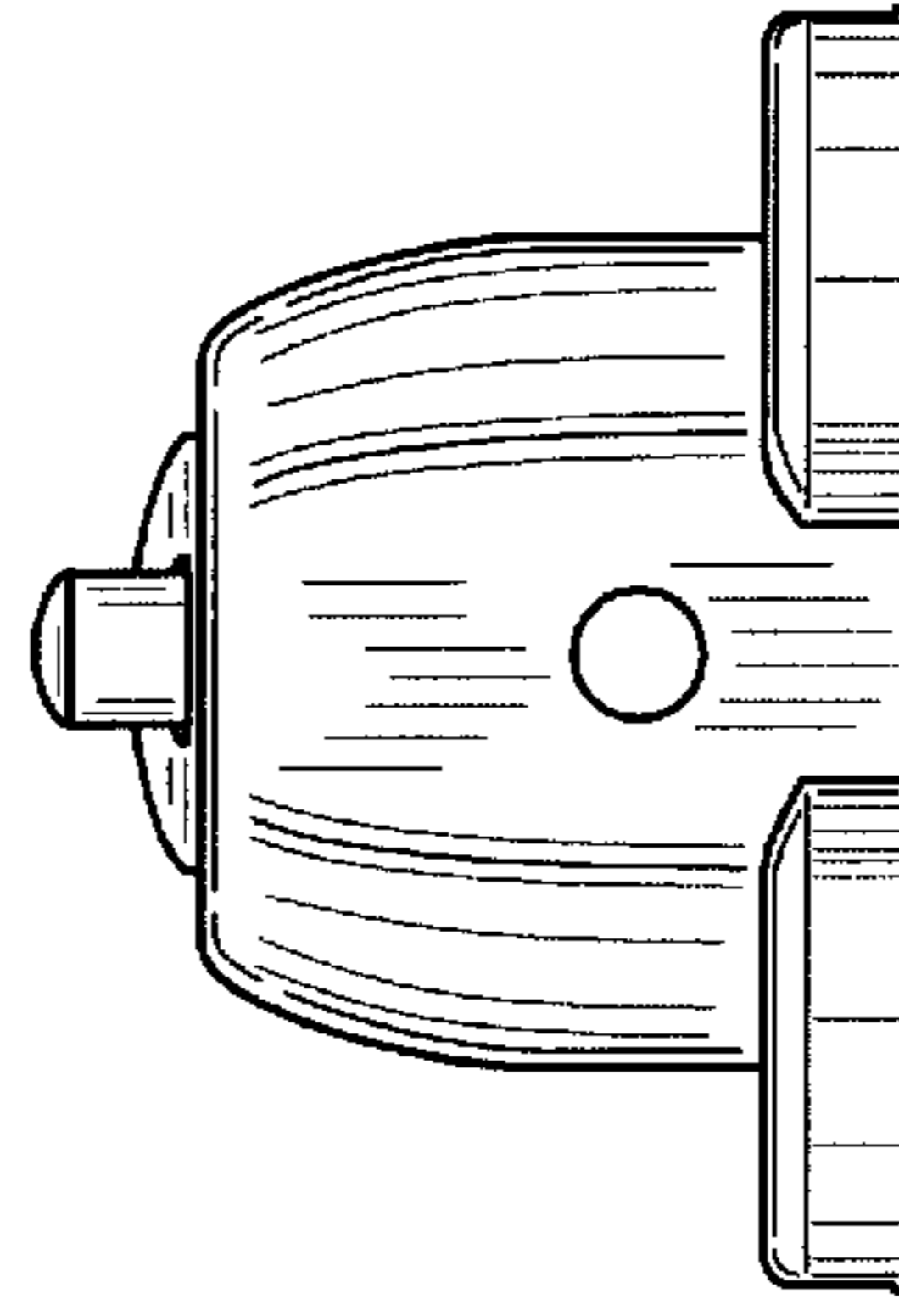

FIG. 6