



US00D517453S

(12) **United States Design Patent** (10) **Patent No.:** **US D517,453 S**
Oosterveer (45) **Date of Patent:** **** Mar. 21, 2006**

- (54) **THREE-WHEELED VEHICLE**
- (76) Inventor: **Horst Oosterveer**, Lissevenlaan 16,
NL-5582 KC Waalre (NL)
- (**) Term: **14 Years**
- (21) Appl. No.: **29/216,916**
- (22) Filed: **Nov. 9, 2004**
- (51) **LOC (8) Cl.** **12-11**
- (52) **U.S. Cl.** **D12/112**
- (58) **Field of Classification Search** D12/112,
D12/113; 280/259, 270, 271, 282, 281.1,
280/288.1, 202, 211; D21/435
- See application file for complete search history.

(56) **References Cited**

U.S. PATENT DOCUMENTS

4,572,535 A 2/1986 Stewart et al.
D465,439 S 11/2002 van de Vrie

FOREIGN PATENT DOCUMENTS

DE 195 11 629 C2 10/1998
DE 100 54 273 A1 5/2002
EP 000005301-0001 7/2003

OTHER PUBLICATIONS

Tom Lockington, Trixstar at www.trixstar.co.uk, Dec. 18, 2004, 1 page.
Rohorn, Inc., Rohorn Mind Expanding Bicycles, S'trike and F'lowroller, www.rohorn.com, Dec. 18, 2004, 1 page.
Author or owner name unknown, Coyote pedal kart, www.letsride1.com/coyote.html, Dec. 18, 2004, 2 pages.
TRAILMATE, Trailmate's Fun Cycle Series, www.trailmate.com/funCycleSeries.cfm, Dec. 18, 2004, 2 pages.
WINTHER, Chili Recumbent Bike, www.a-winter.com/pages/viking/others_485.00.php, Dec. 18, 2004, 2 pages.
BERG, BalanzBike, www.bergtoys.com/languages/balanzbike.php?model=bazzic, Dec. 18, 2004, 1 page.

Author or owner name unknown, Triker Rock The Streets, Users manual, Dec. 18, 2004, 1 page.
Author or owner name unknown, Big Wheel, <http://toyclassics.com/product.asp?pn=1995>, Dec. 18, 2004, 1 page.
Toyvision Trading B.V., ZigZag users manual, date unknown, 1 page.
Toyvision Trading B.V., Viper users manual, date unknown, 1 page.

Primary Examiner—Alan P. Douglas
Assistant Examiner—Linda Brooks
(74) *Attorney, Agent, or Firm*—Schwabe, Williamson and Wyatt

(57) **CLAIM**

I claim the ornamental design for a three-wheeled vehicle, as shown and described.

DESCRIPTION

FIG. 1 illustrates a rear right perspective view of an ornamental design of the three-wheeled vehicle in accordance with the present invention;
FIG. 2 illustrates a front left perspective view of the invention of FIG. 1;
FIG. 3 illustrates a rear left perspective view of the invention of FIG. 1;
FIG. 4 illustrates a bottom elevational view of the invention of FIG. 1;
FIG. 5 illustrates a top elevational view of the invention of FIG. 1;
FIG. 6 illustrates a left side elevational view of the invention of FIG. 1; and,
FIG. 7 illustrates a right side elevational view of the invention of FIG. 1.
The broken lines shown are directed to the environment and are for illustrative purposes only; the broken lines form no part of the claimed design.

1 Claim, 7 Drawing Sheets

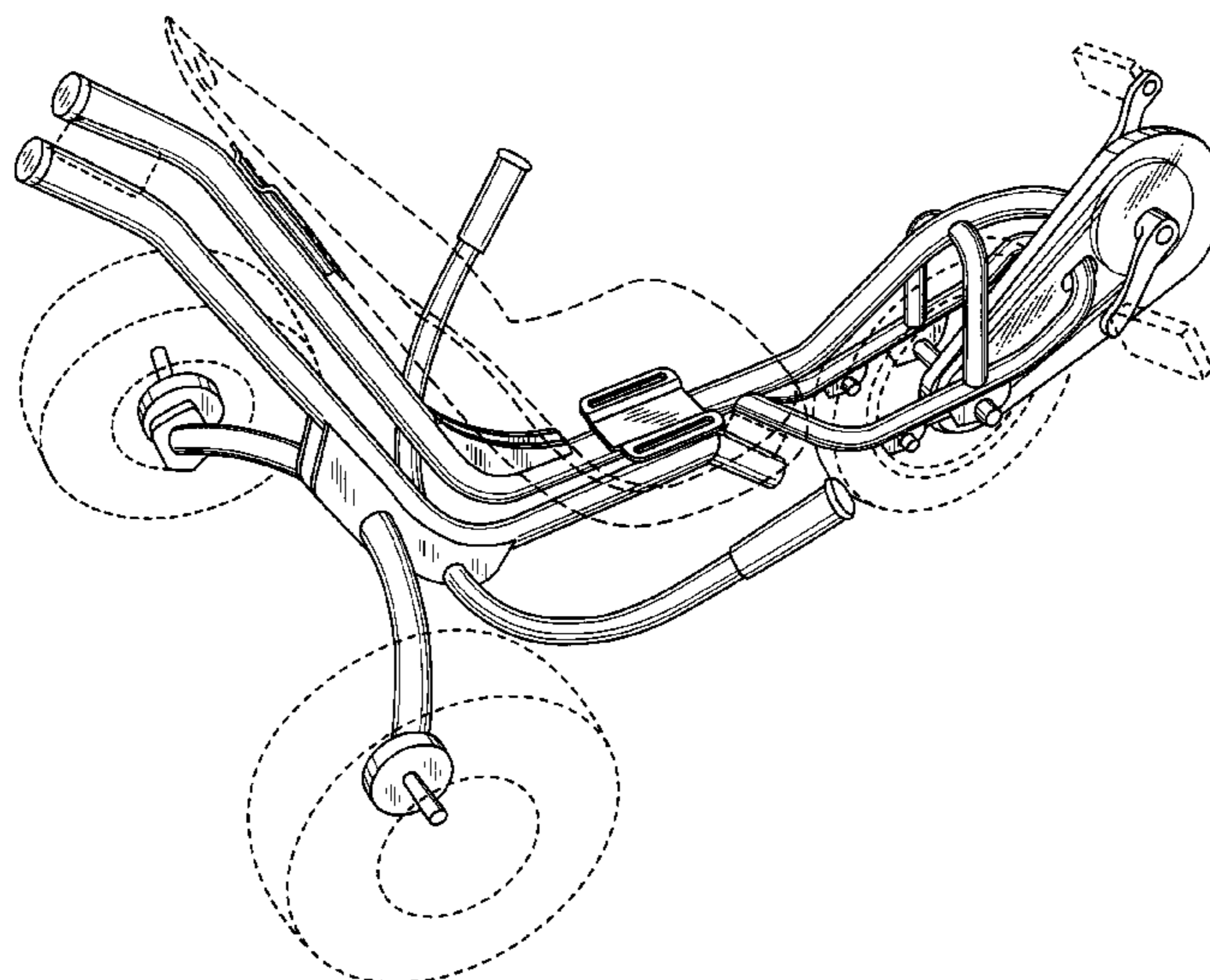

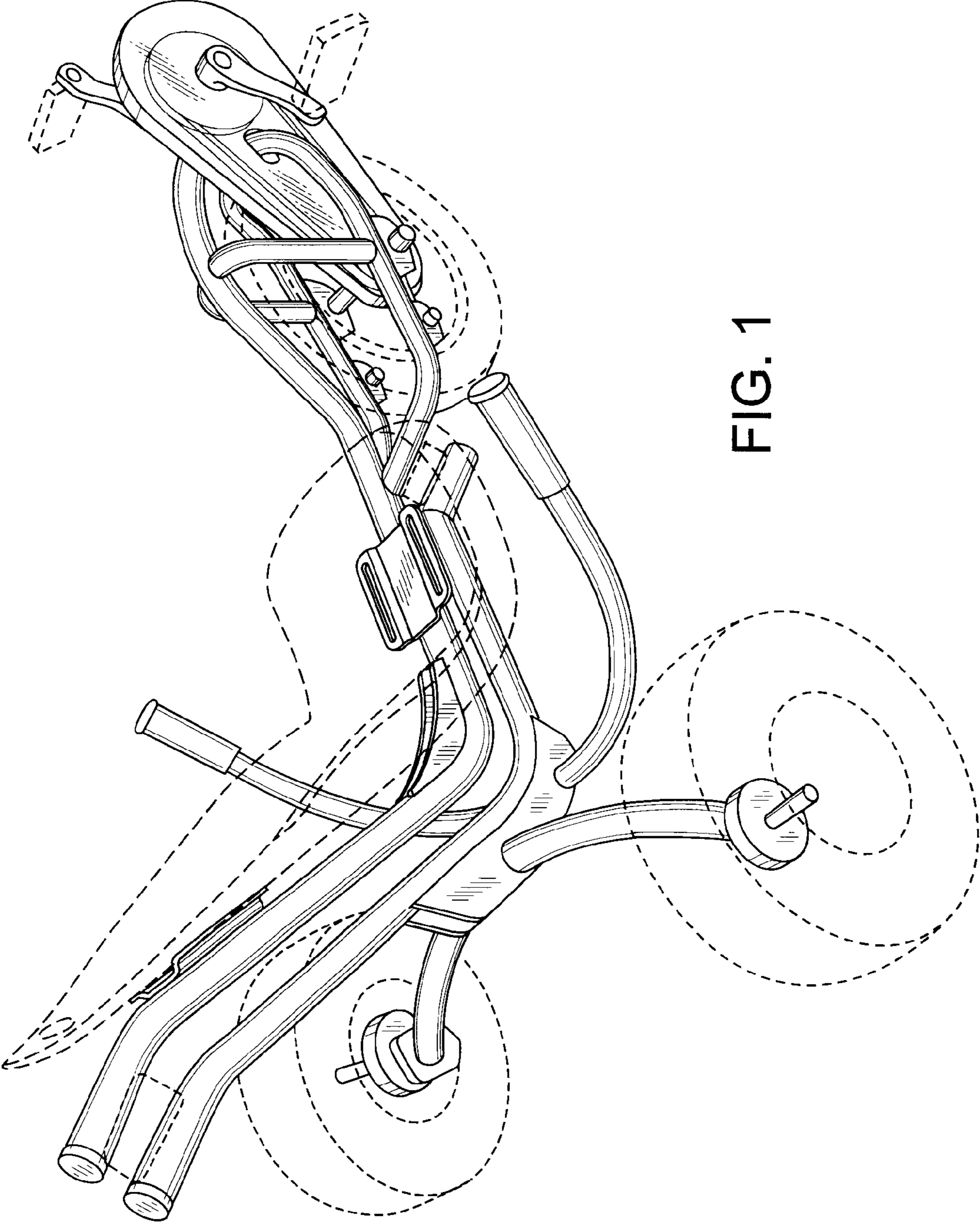
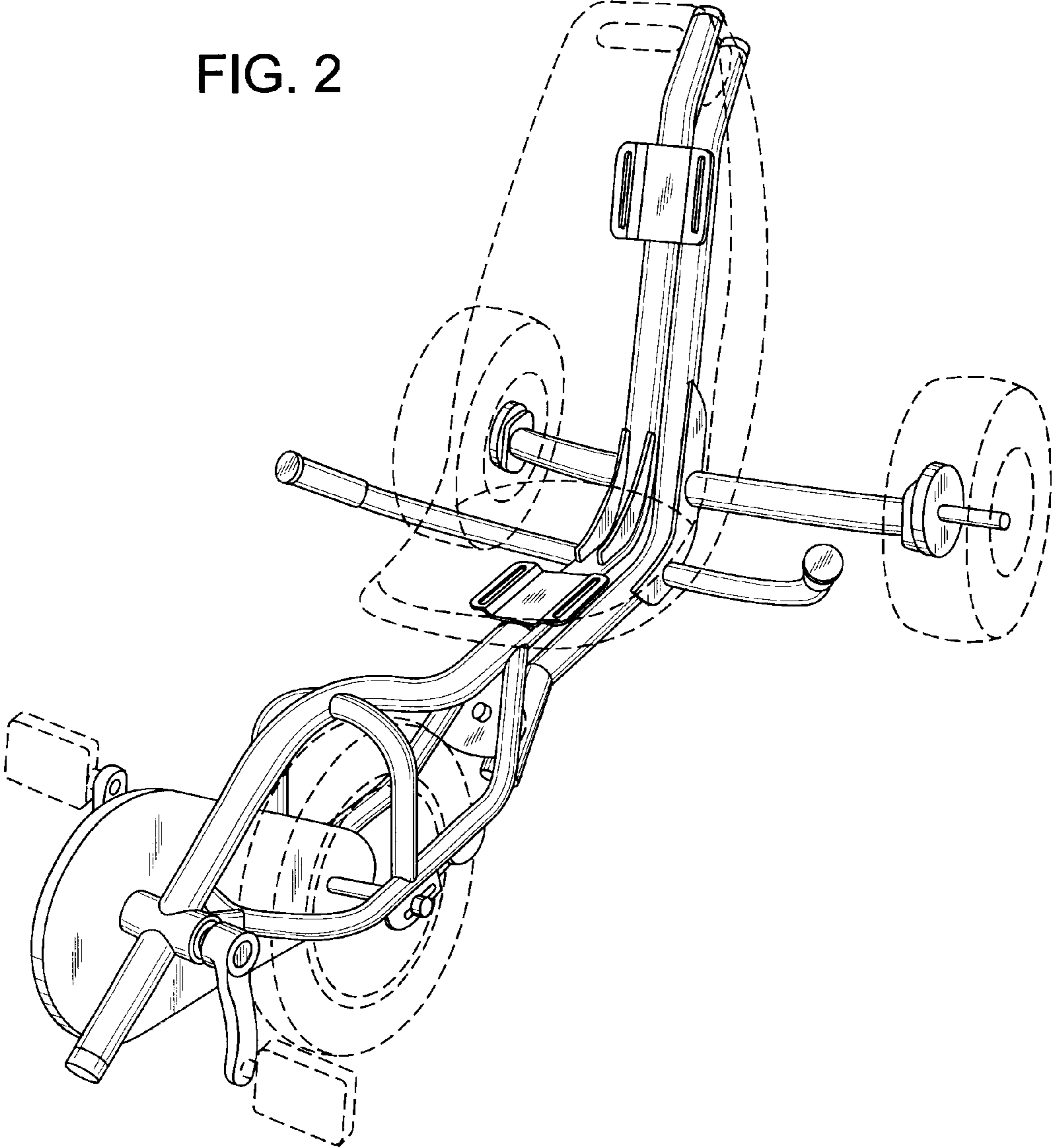

FIG. 1

FIG. 2



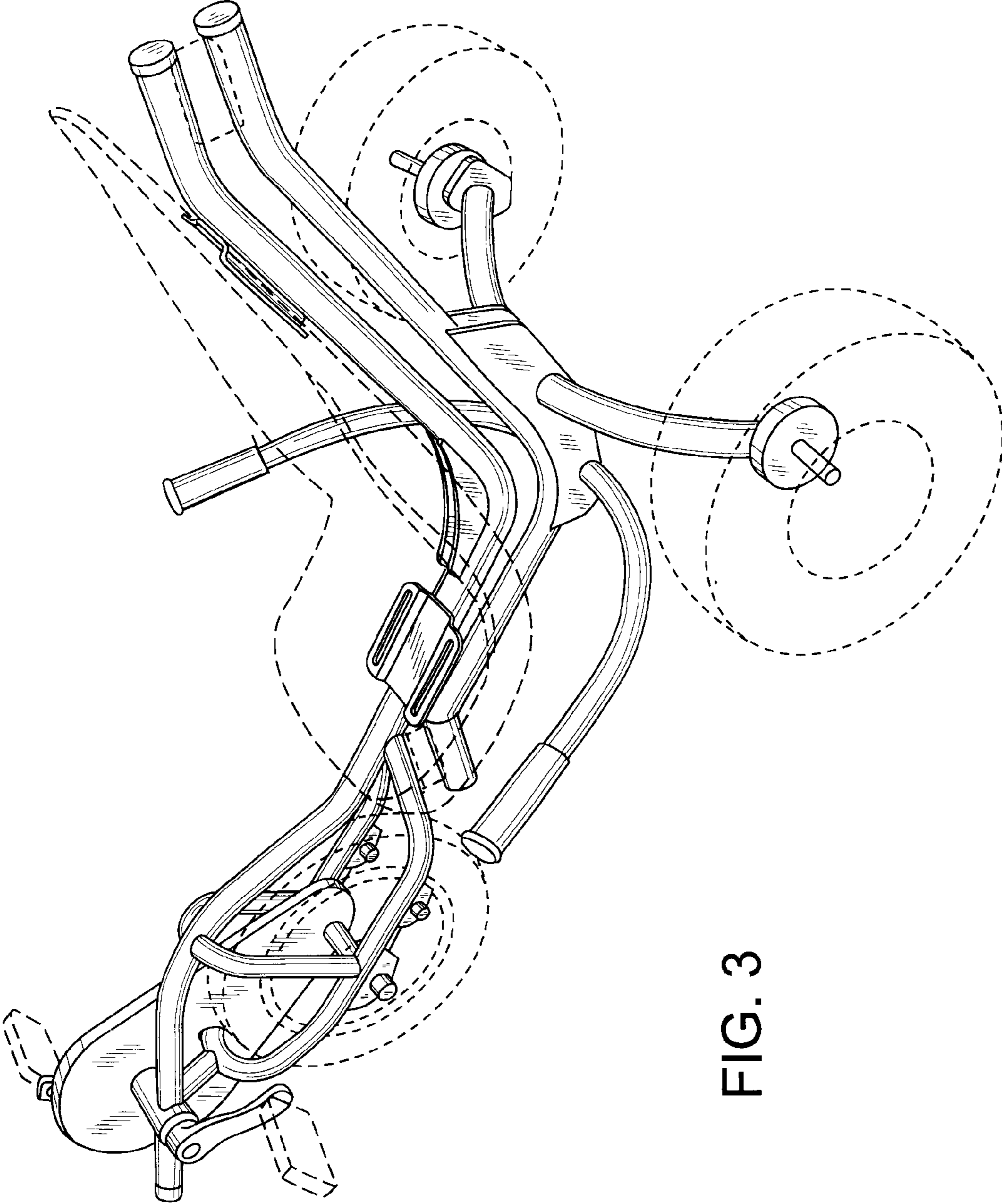

FIG. 3

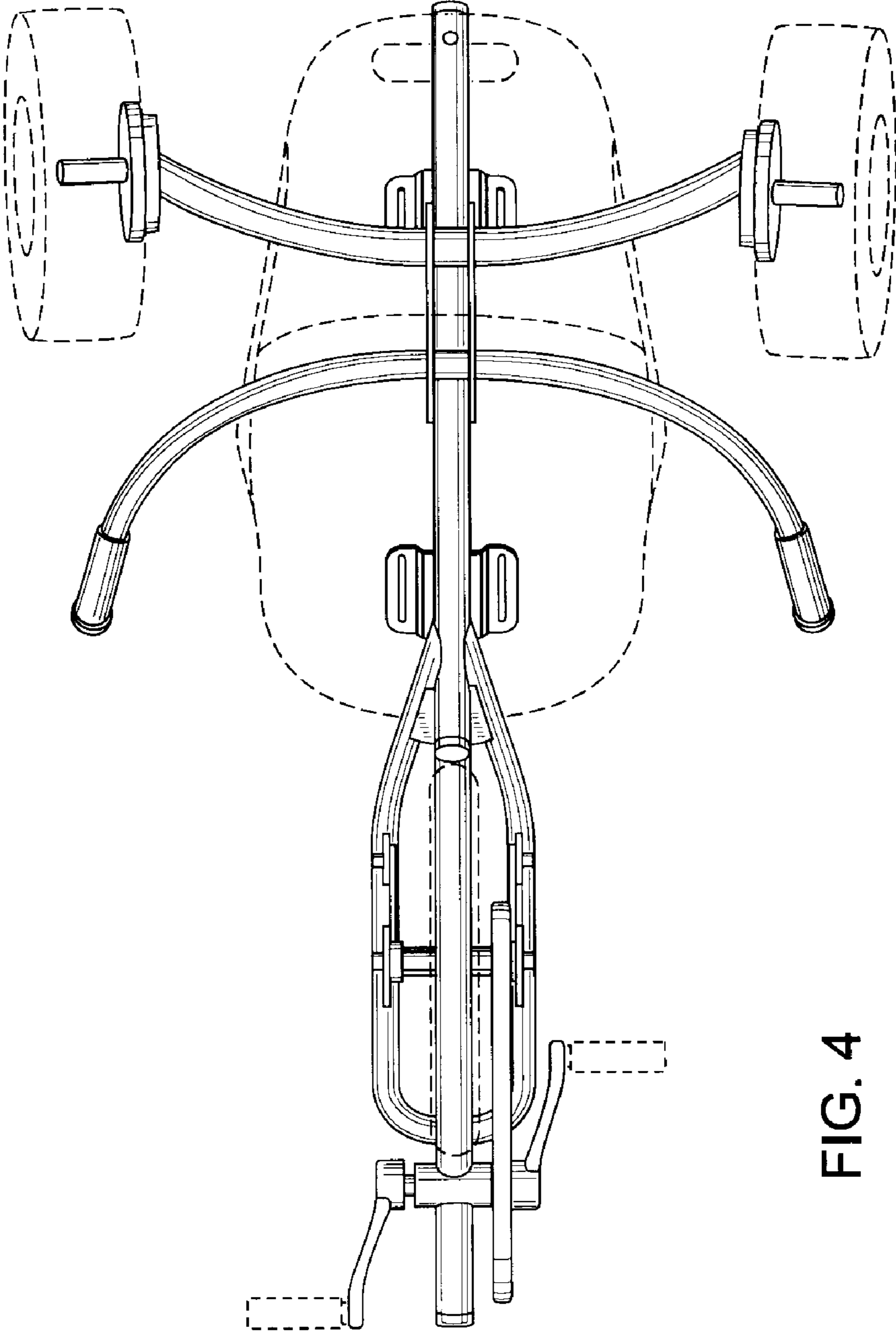

FIG. 4

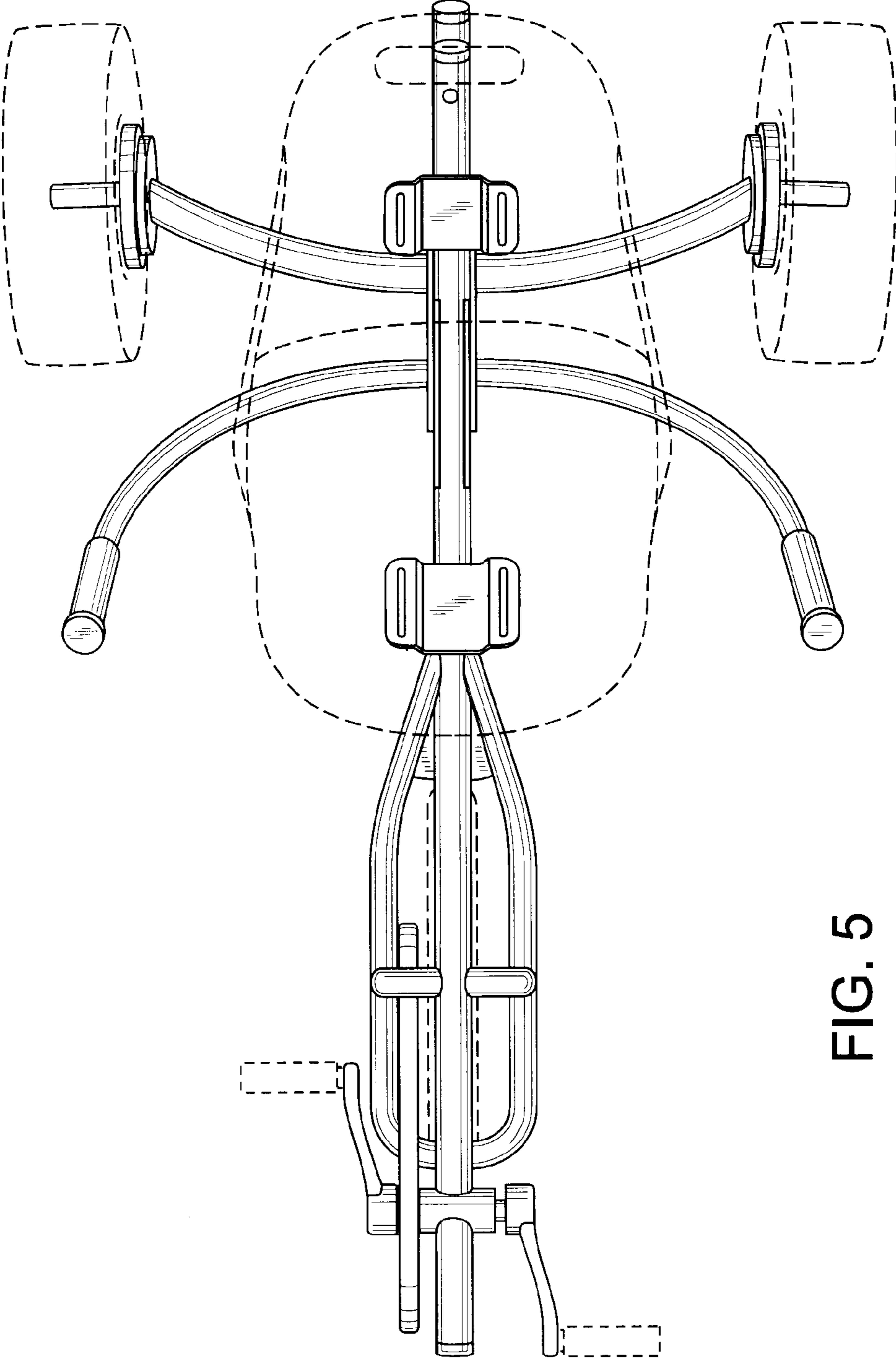

FIG. 5

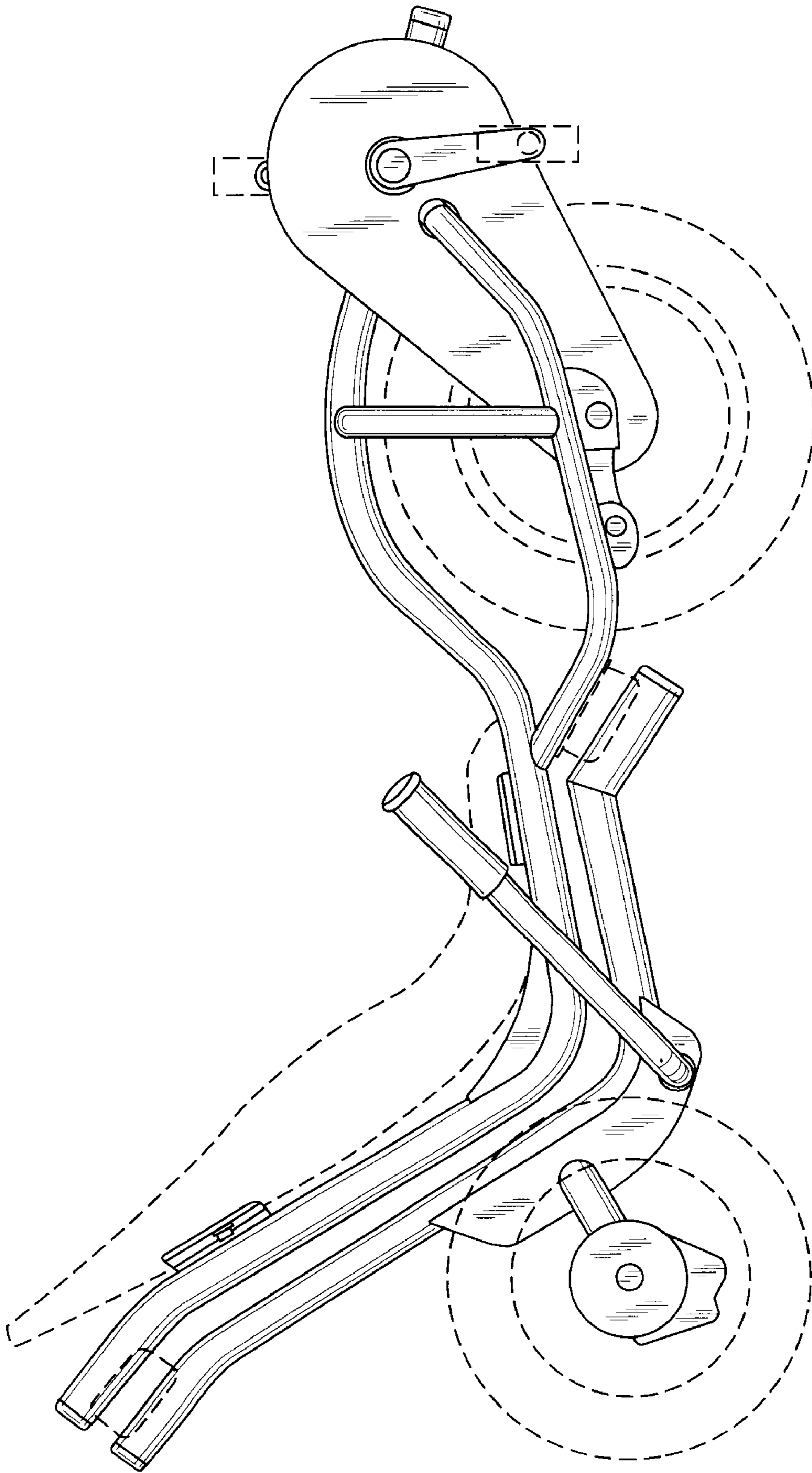

FIG. 6

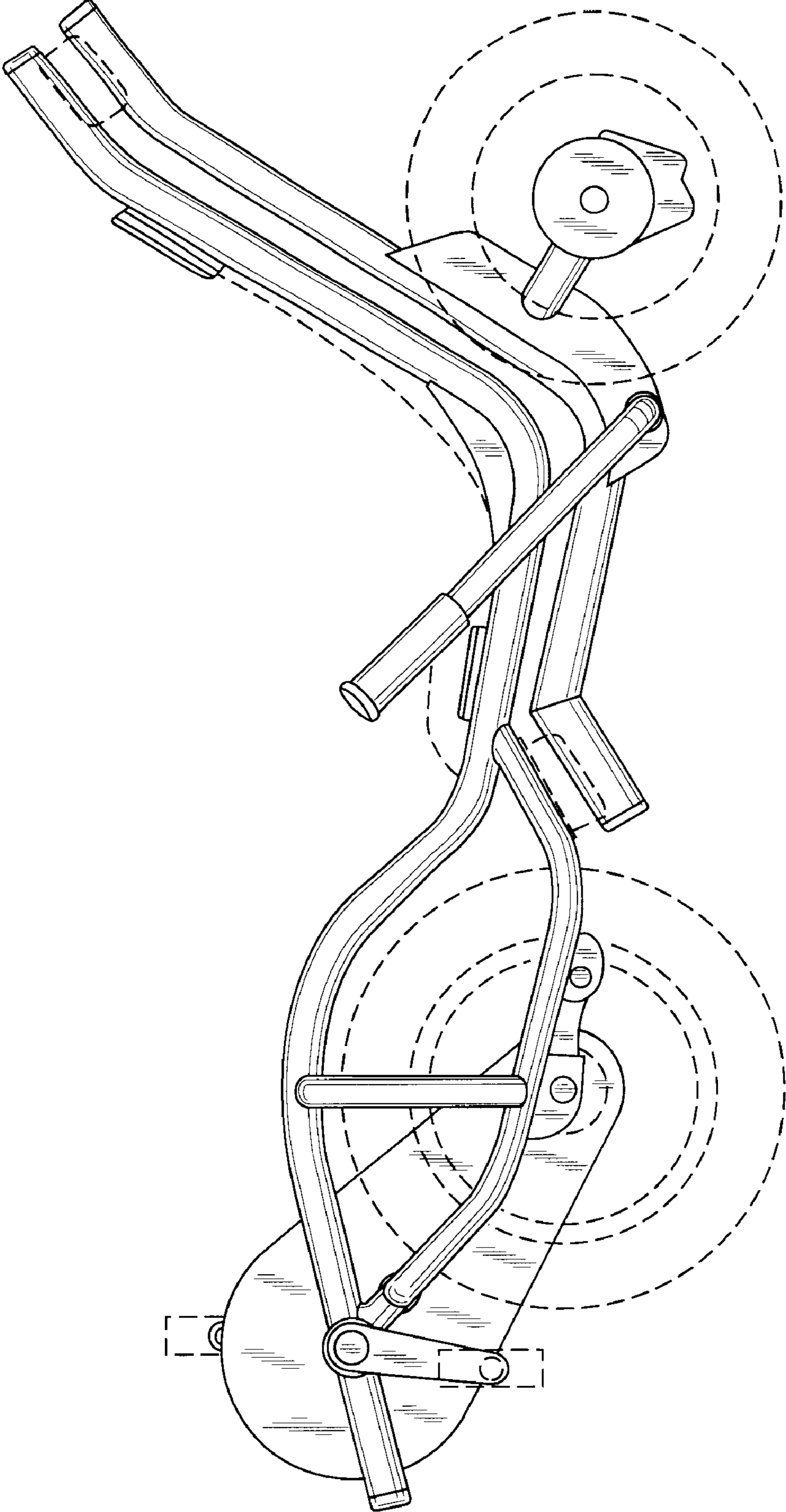

FIG. 7