



US00D516957S

(12) **United States Design Patent**
O'Connell et al.

(10) **Patent No.:** **US D516,957 S**
(45) **Date of Patent:** **** Mar. 14, 2006**

(54) **AUTOMOBILE BODY**

(75) Inventors: **David O'Connell**, Huntington Beach, CA (US); **Daniel J. Sims**, Lake Forest, CA (US)

(73) Assignee: **Mitsubishi Jidosha Kogyo Kabushiki Kaisha**, Tokyo (JP)

(**) Term: **14 Years**

(21) Appl. No.: **29/220,726**

(22) Filed: **Jan. 6, 2005**

(51) **LOC (8) Cl.** **12-16**

(52) **U.S. Cl.** **D12/91; D12/98**

(58) **Field of Classification Search** D12/90-92,
D12/86; 296/181.1, 181.3
See application file for complete search history.

(56) **References Cited**

U.S. PATENT DOCUMENTS

D474,716 S	*	5/2003	Wakao	D12/91
D481,656 S	*	11/2003	Fukushima	D12/98
D494,105 S	*	8/2004	Hall et al.	D12/98
D504,357 S	*	4/2005	Aneiros et al.	D12/98

* cited by examiner

Primary Examiner—Melody N. Brown

(74) *Attorney, Agent, or Firm*—Birch, Stewart, Kolasch & Birch, LLP

(57) **CLAIM**

The ornamental design for an automobile body, as shown and described.

DESCRIPTION

FIG. 1 is a front view of an automobile body showing our new design constructed according to our novel design;
 FIG. 2 is a top plan view thereof;
 FIG. 3 is a right side view thereof;
 FIG. 4 is a left side view thereof;
 FIG. 5 is a rear view thereof;
 FIG. 6 is a front right elevation perspective view thereof;
 FIG. 7 is a rear left elevation perspective view thereof;
 FIG. 8 is a front view of another embodiment of an automobile body showing our new design;
 FIG. 9 is a top plan view of the automobile of FIG. 8;
 FIG. 10 is a right side view of the automobile of FIG. 8;
 FIG. 11 is a left side view of the automobile of FIG. 8;
 FIG. 12 is a rear view of the automobile of FIG. 8;
 FIG. 13 is a front right elevation perspective view of the automobile of FIG. 8; and,
 FIG. 14 is a rear left elevation side elevation view of the automobile of FIG. 8.

The broken lines showing of environmental structure in FIGS. 1-14 of the drawing are for illustrative purposes only and form no part of the claimed design.

1 Claim, 14 Drawing Sheets

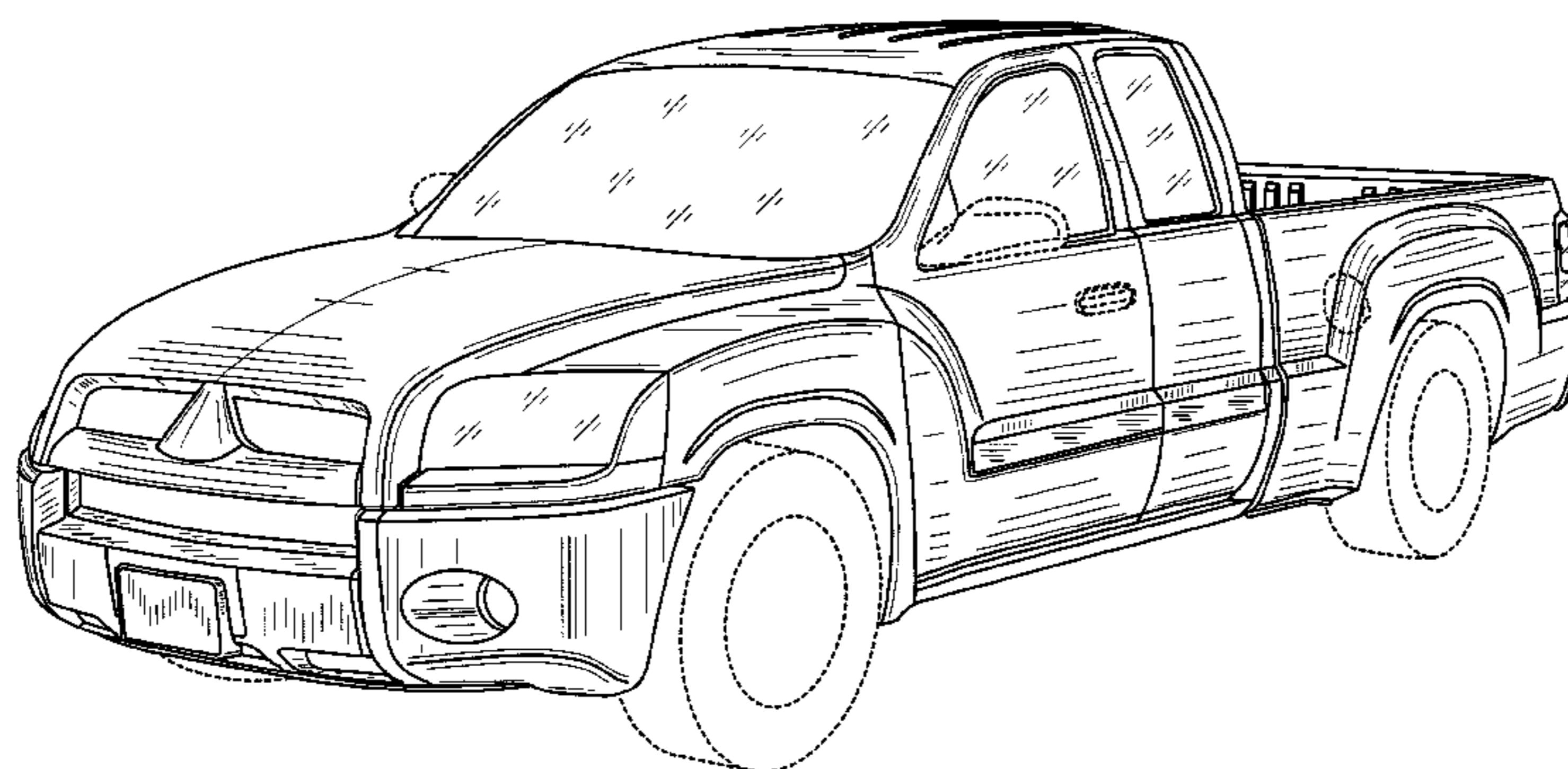
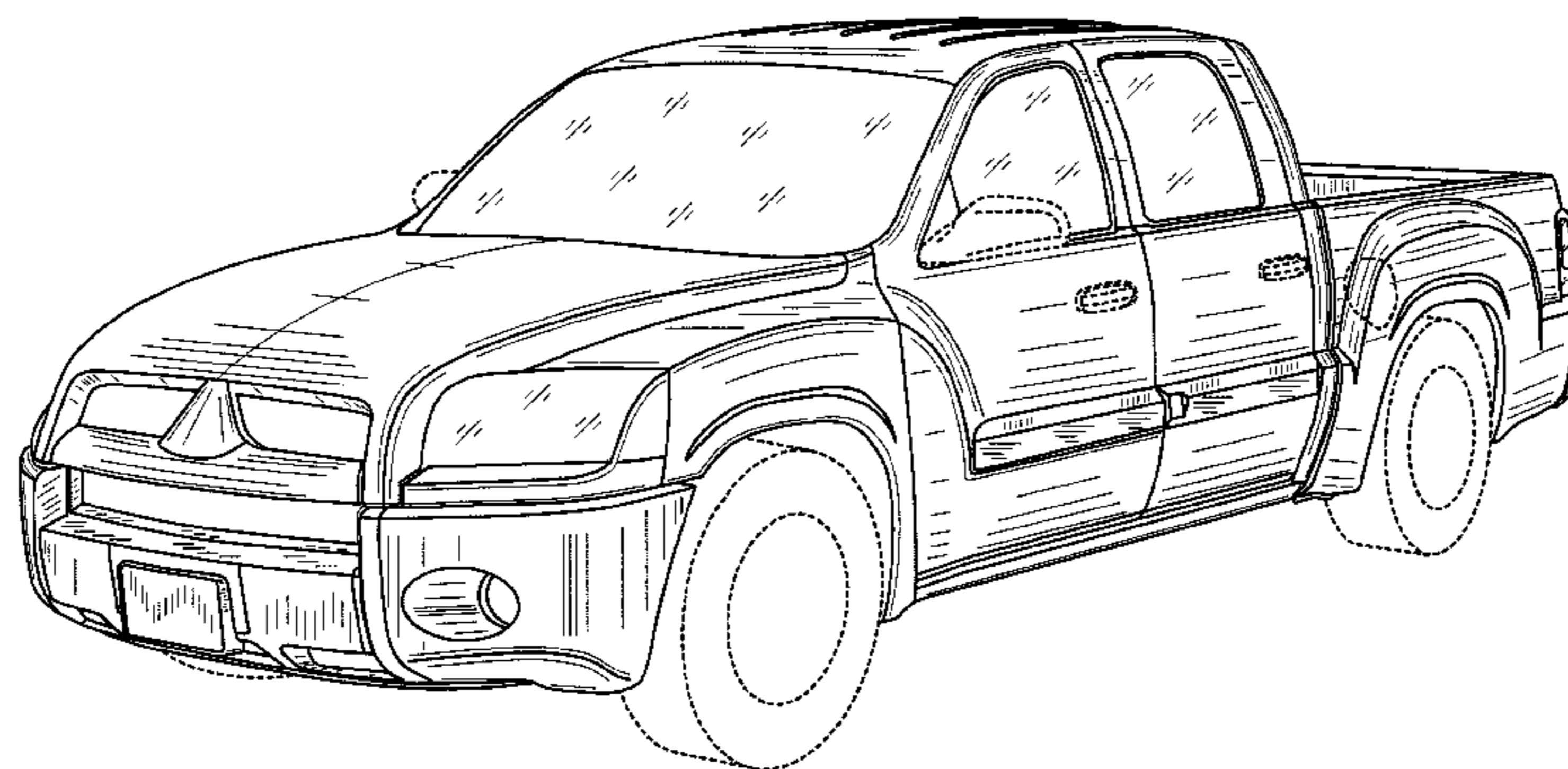

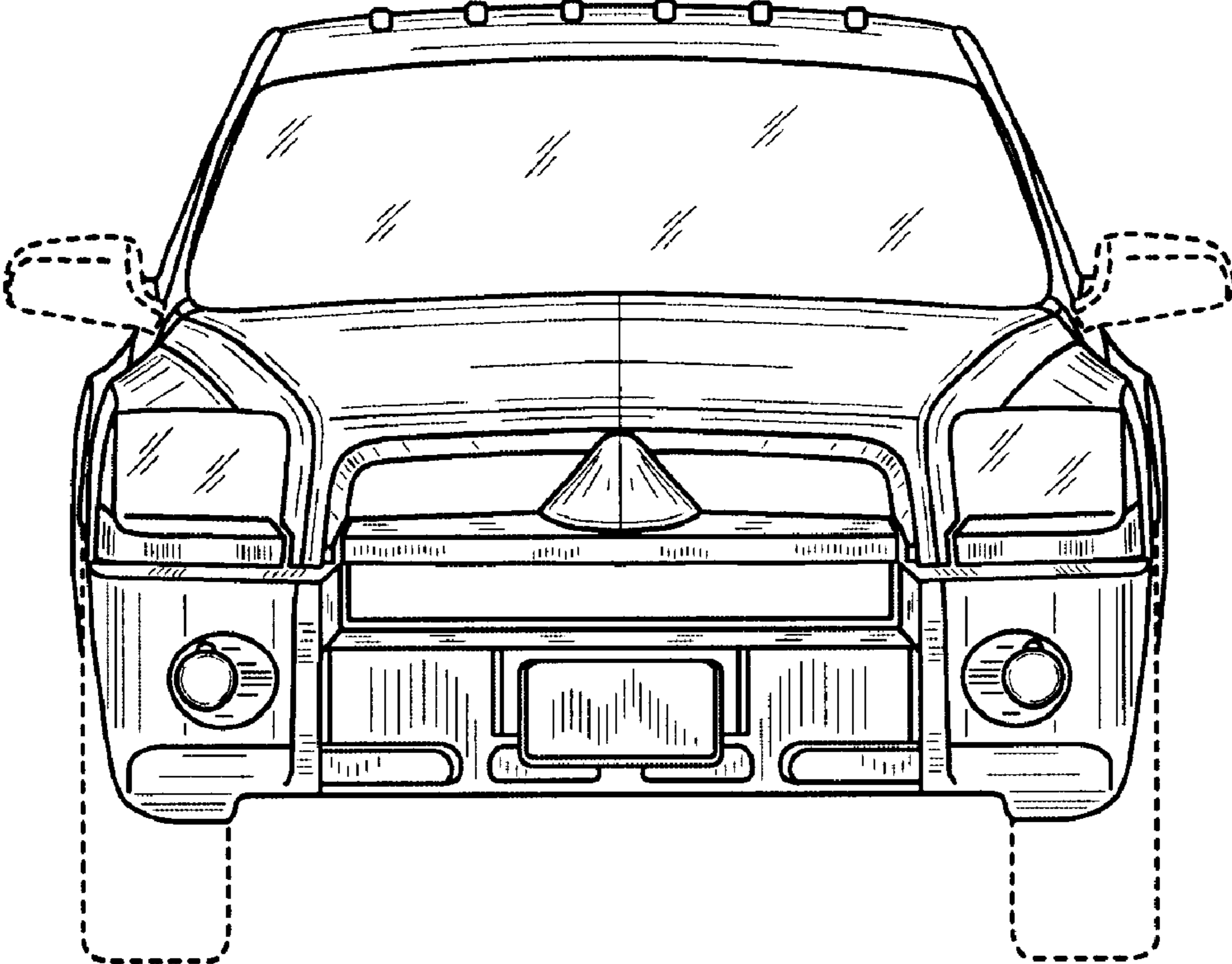

FIG. 1

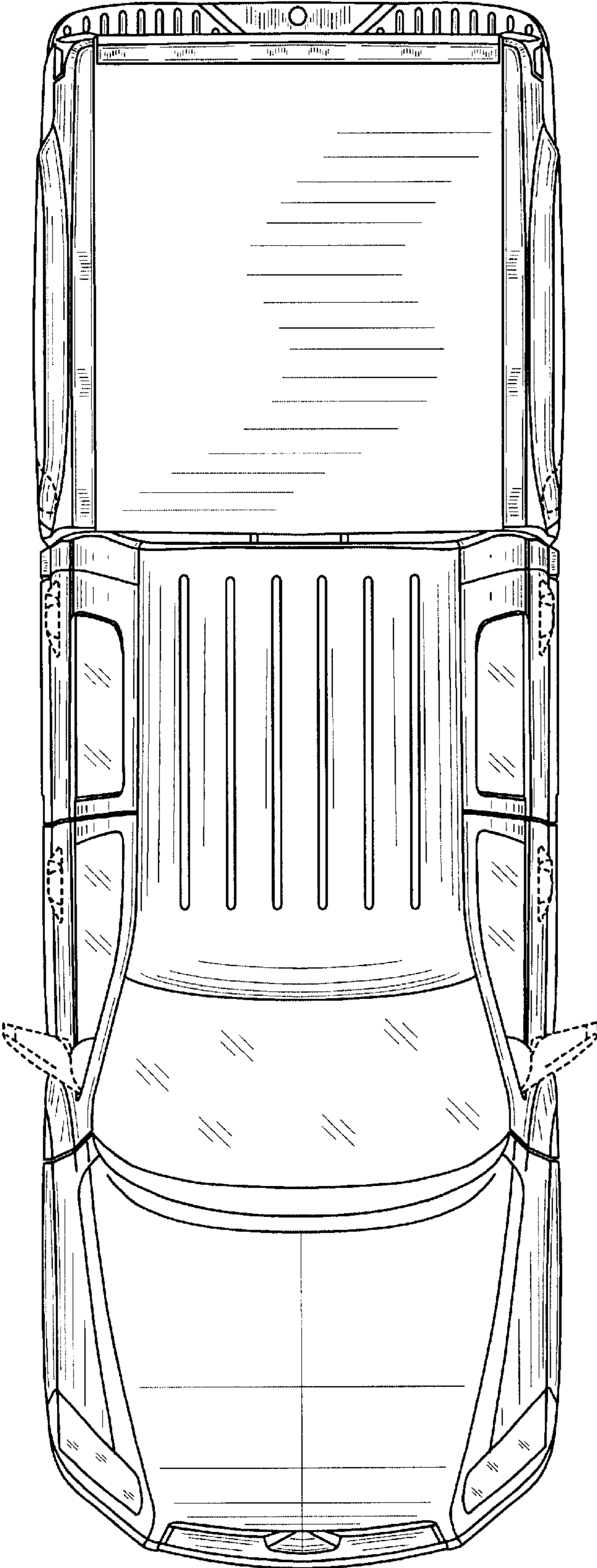

FIG. 2

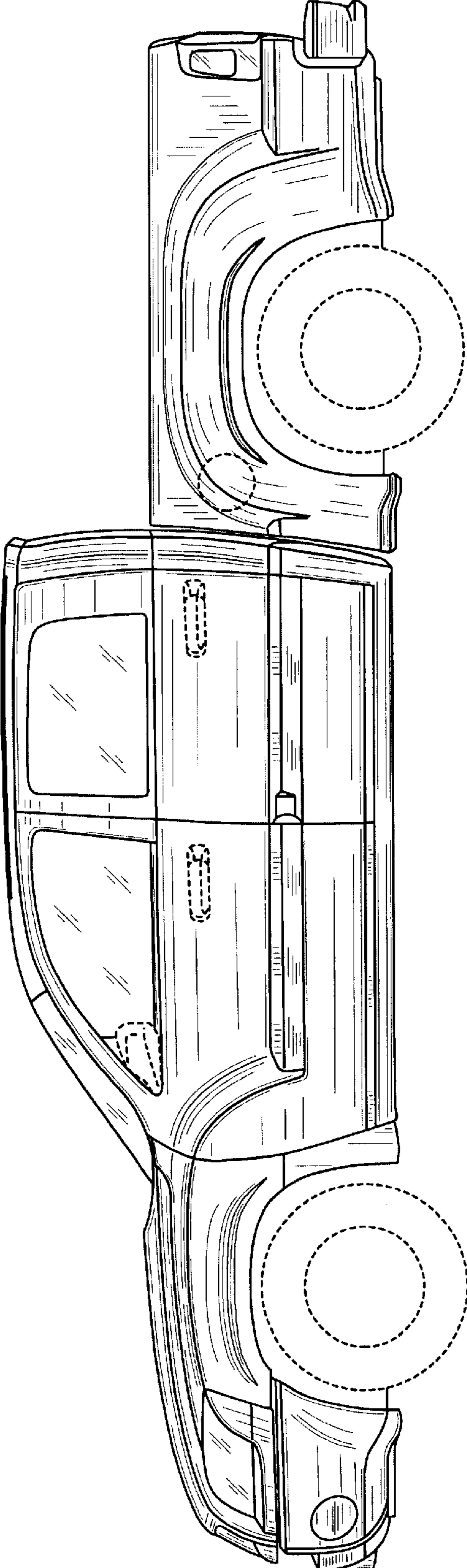

FIG. 3

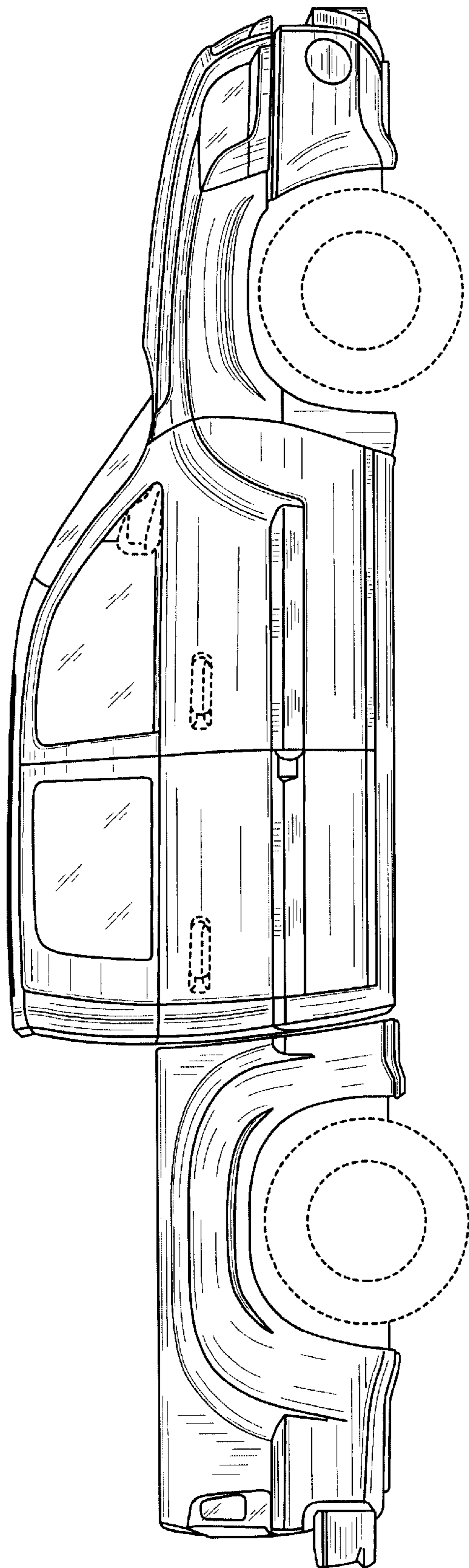

FIG. 4

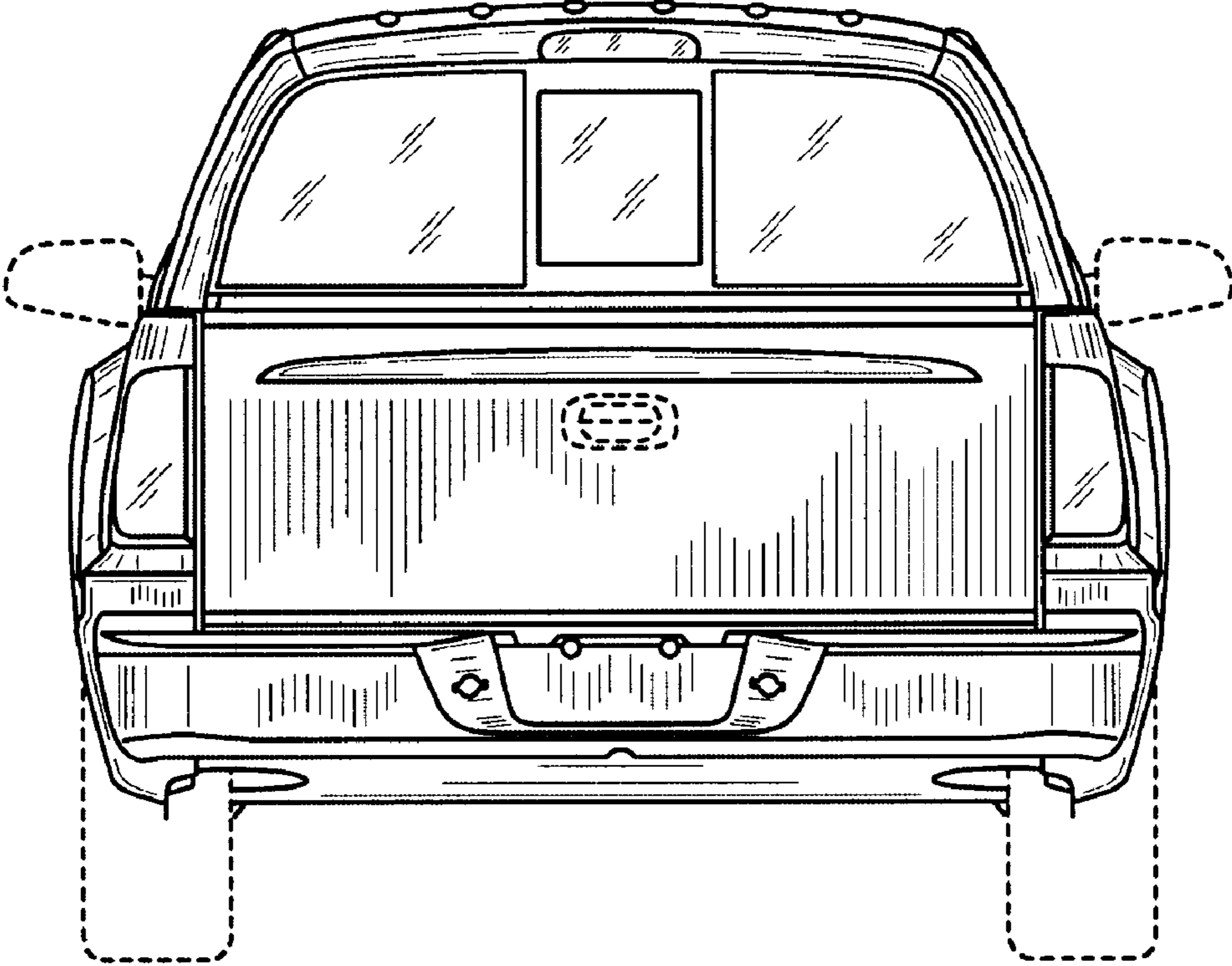

FIG. 5

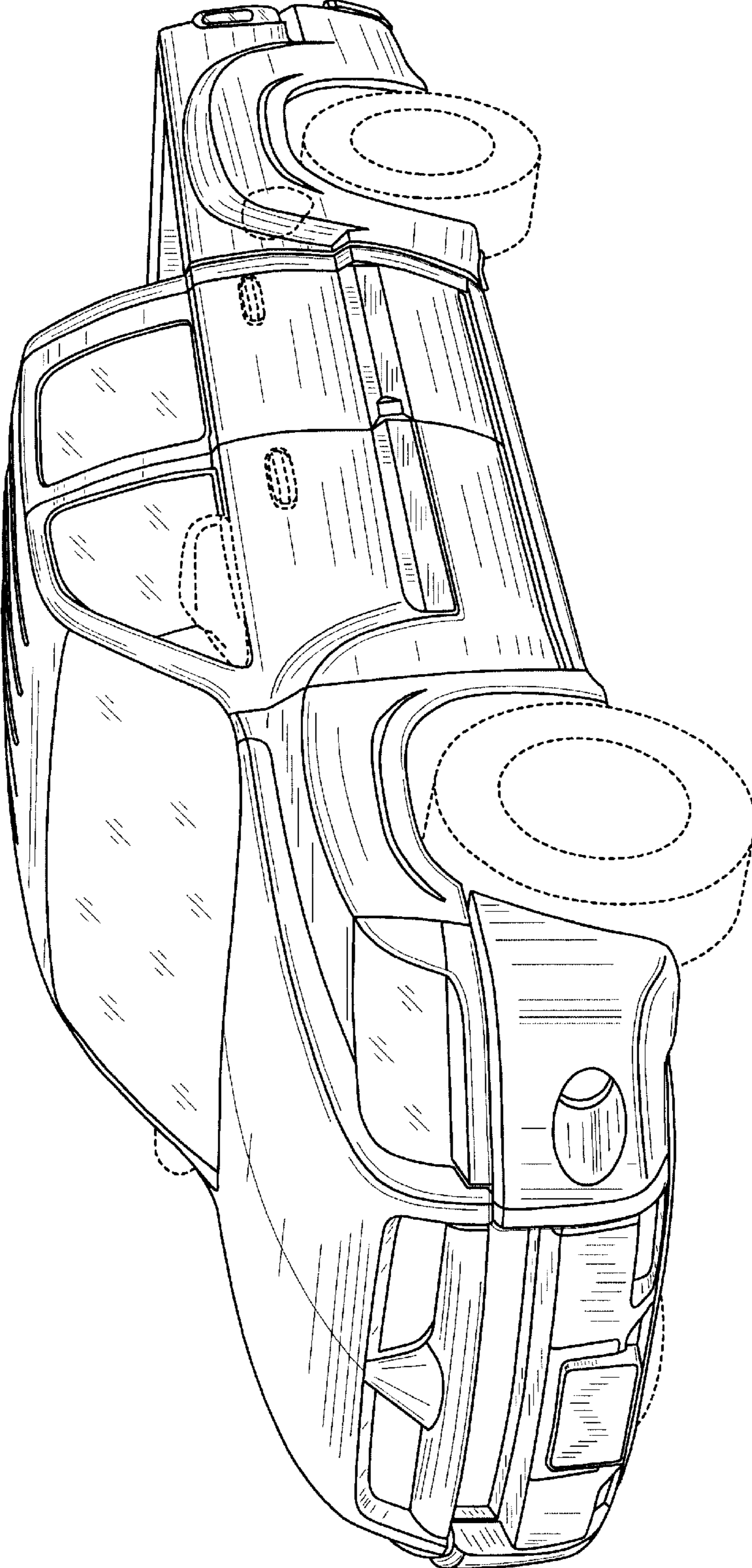

FIG. 6

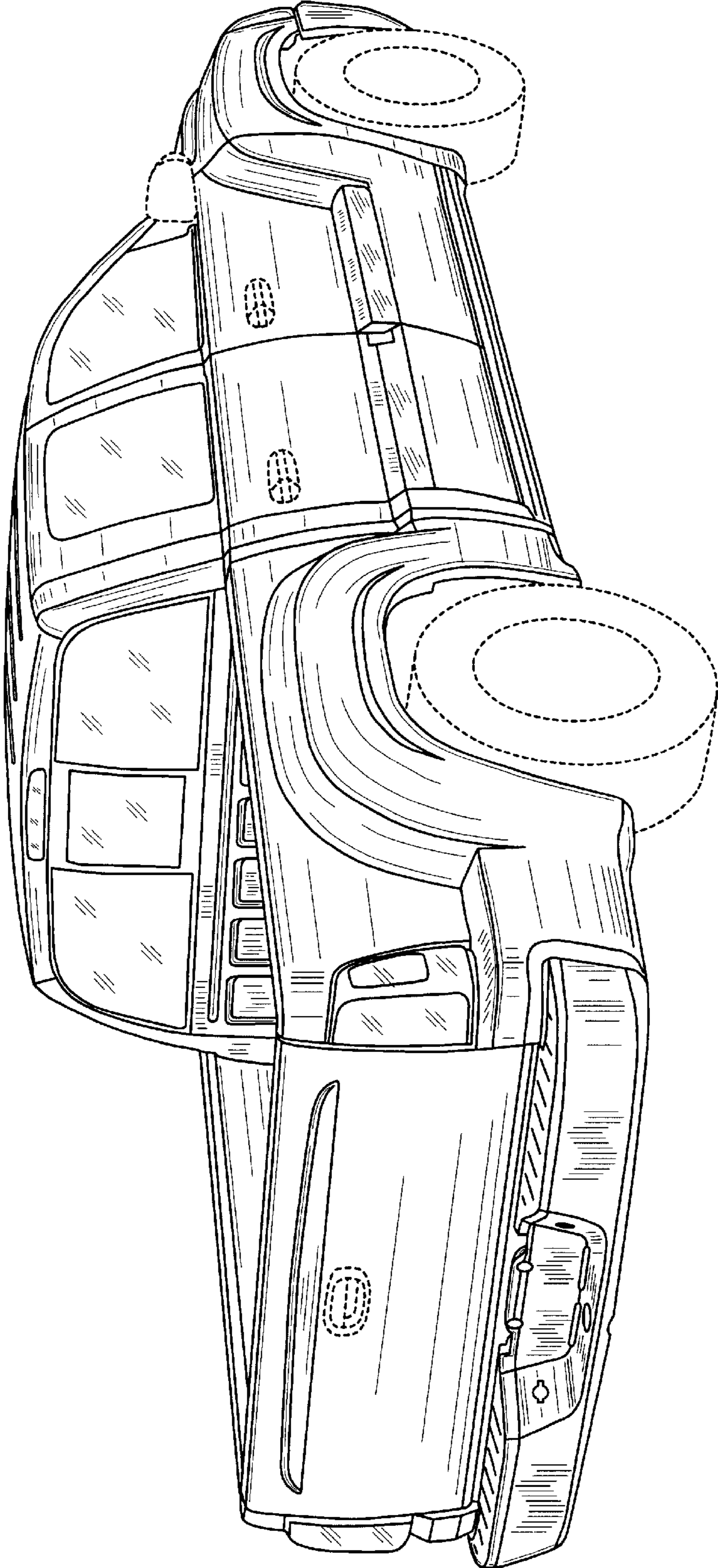

FIG. 7

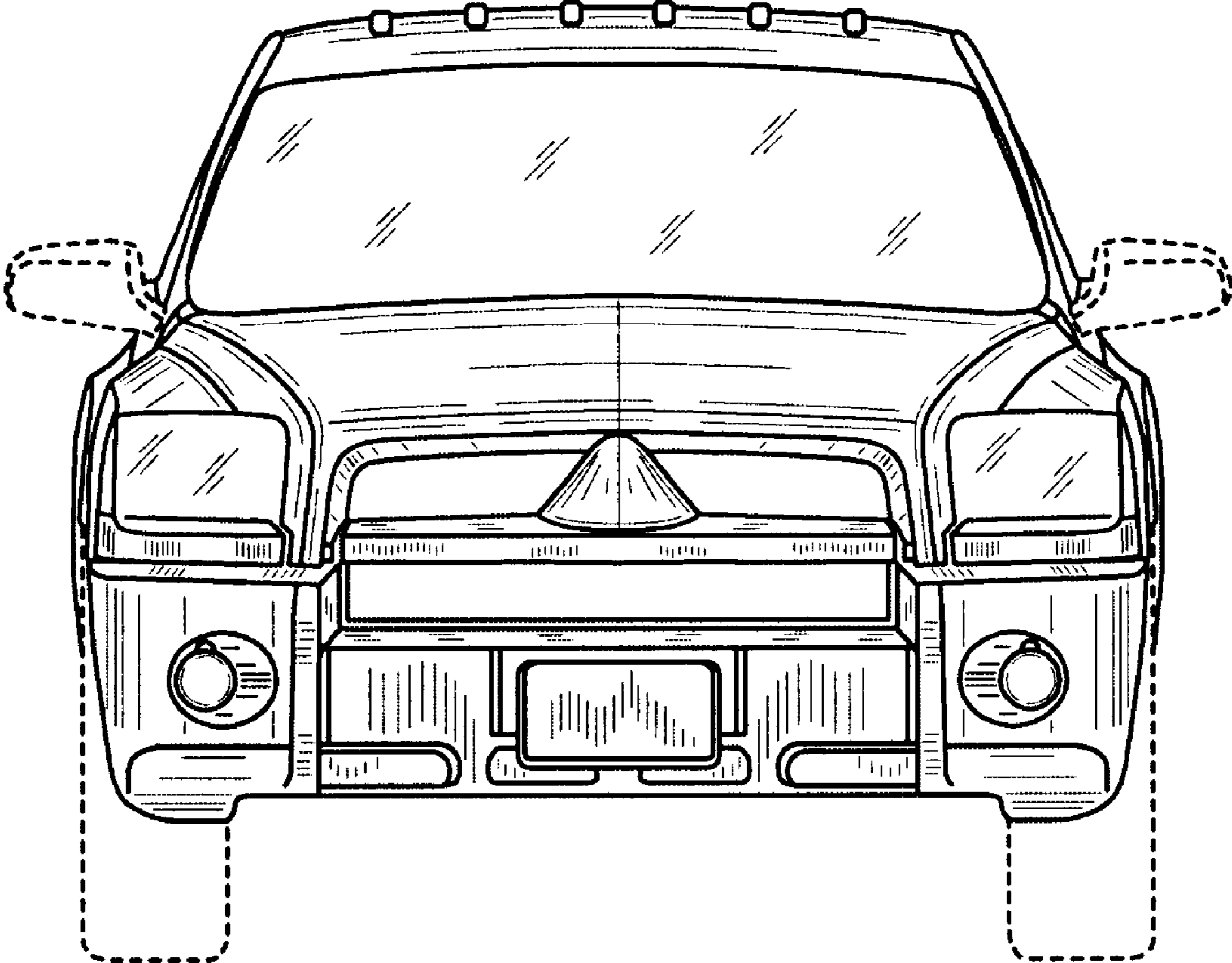

FIG. 8

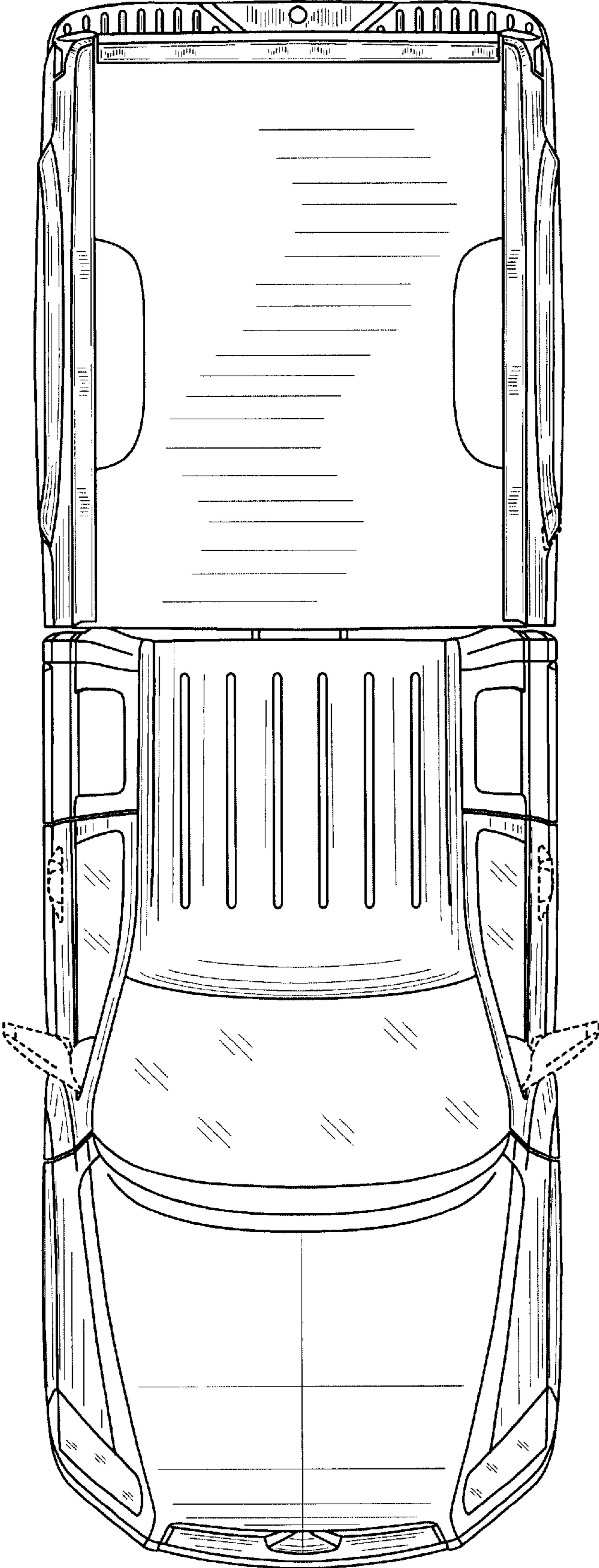

FIG. 9

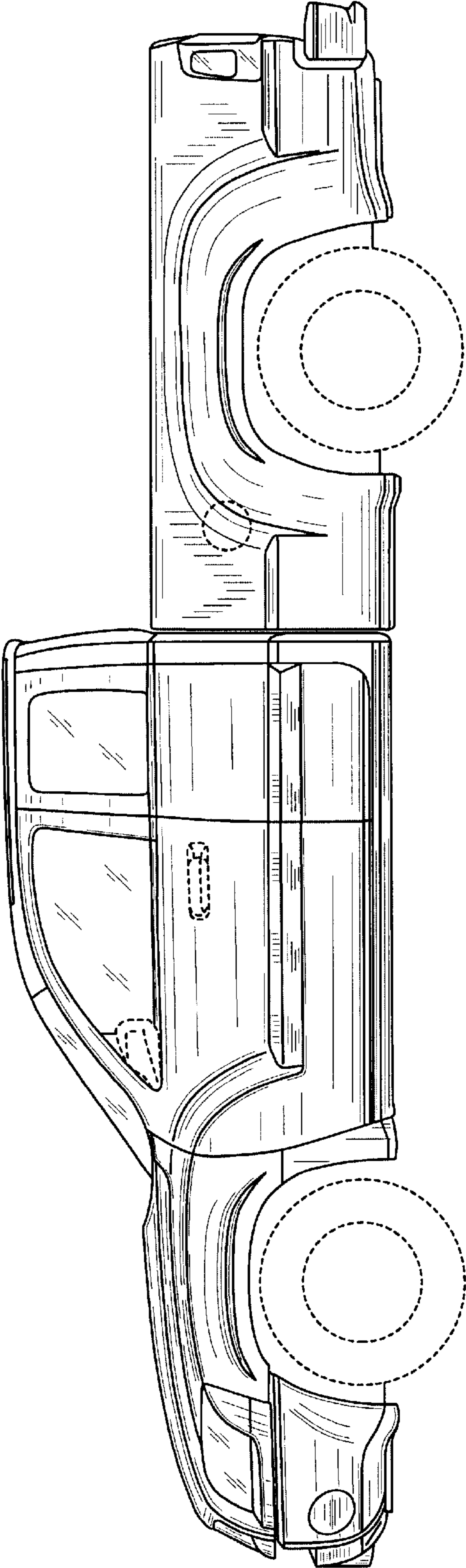

FIG. 10

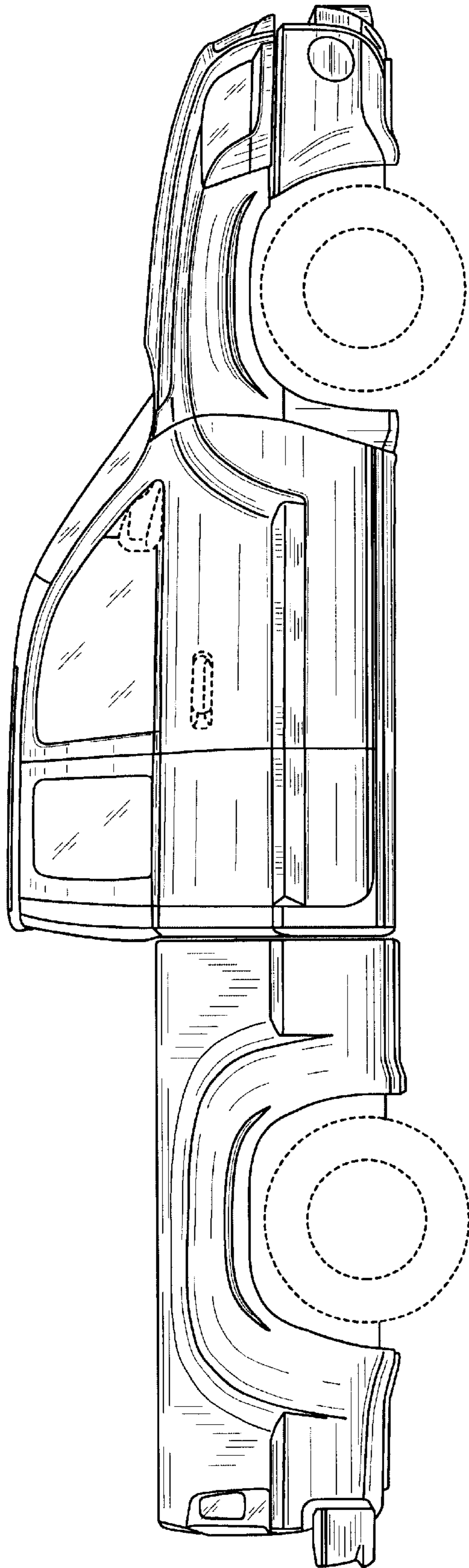

FIG. 11

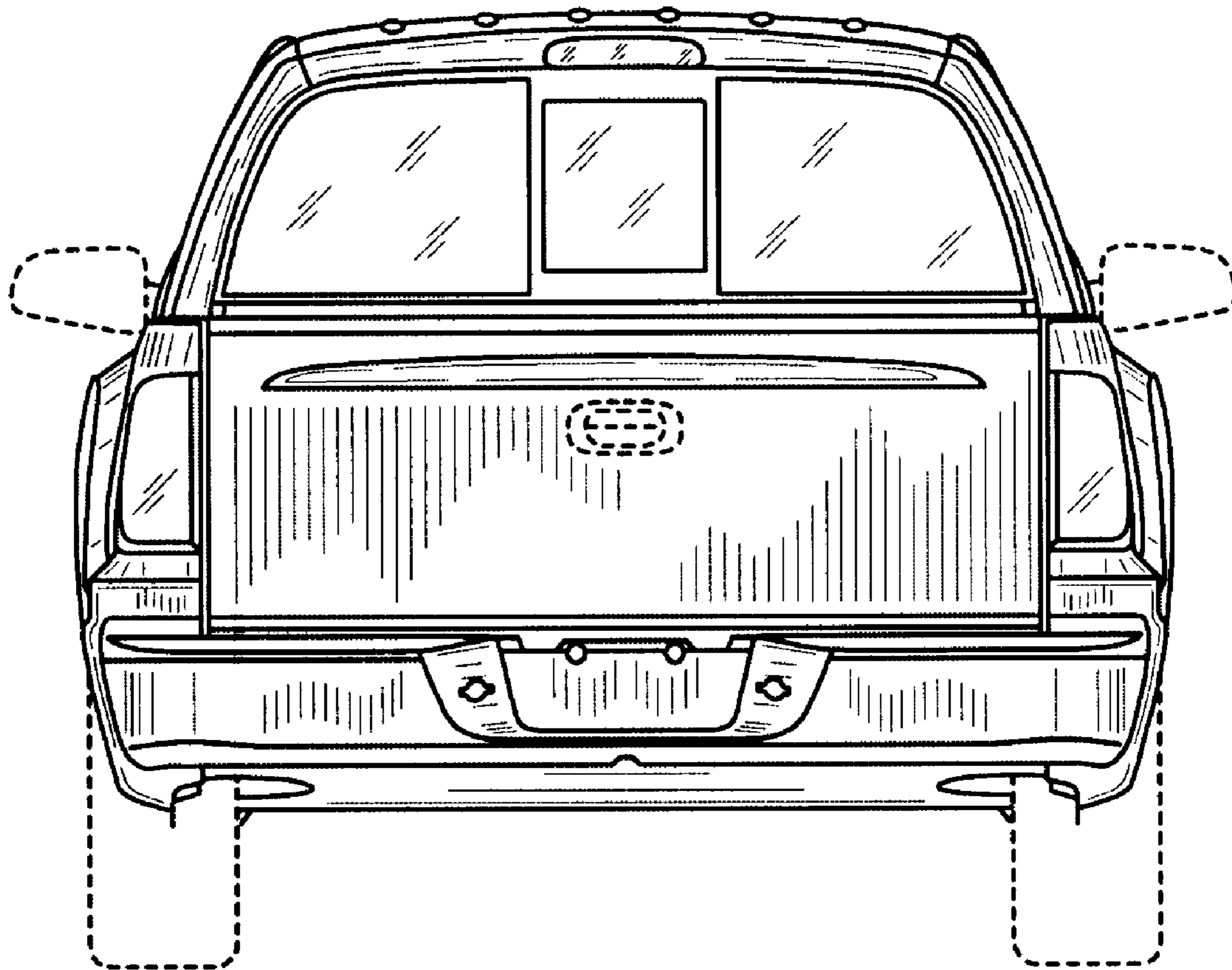

FIG. 12

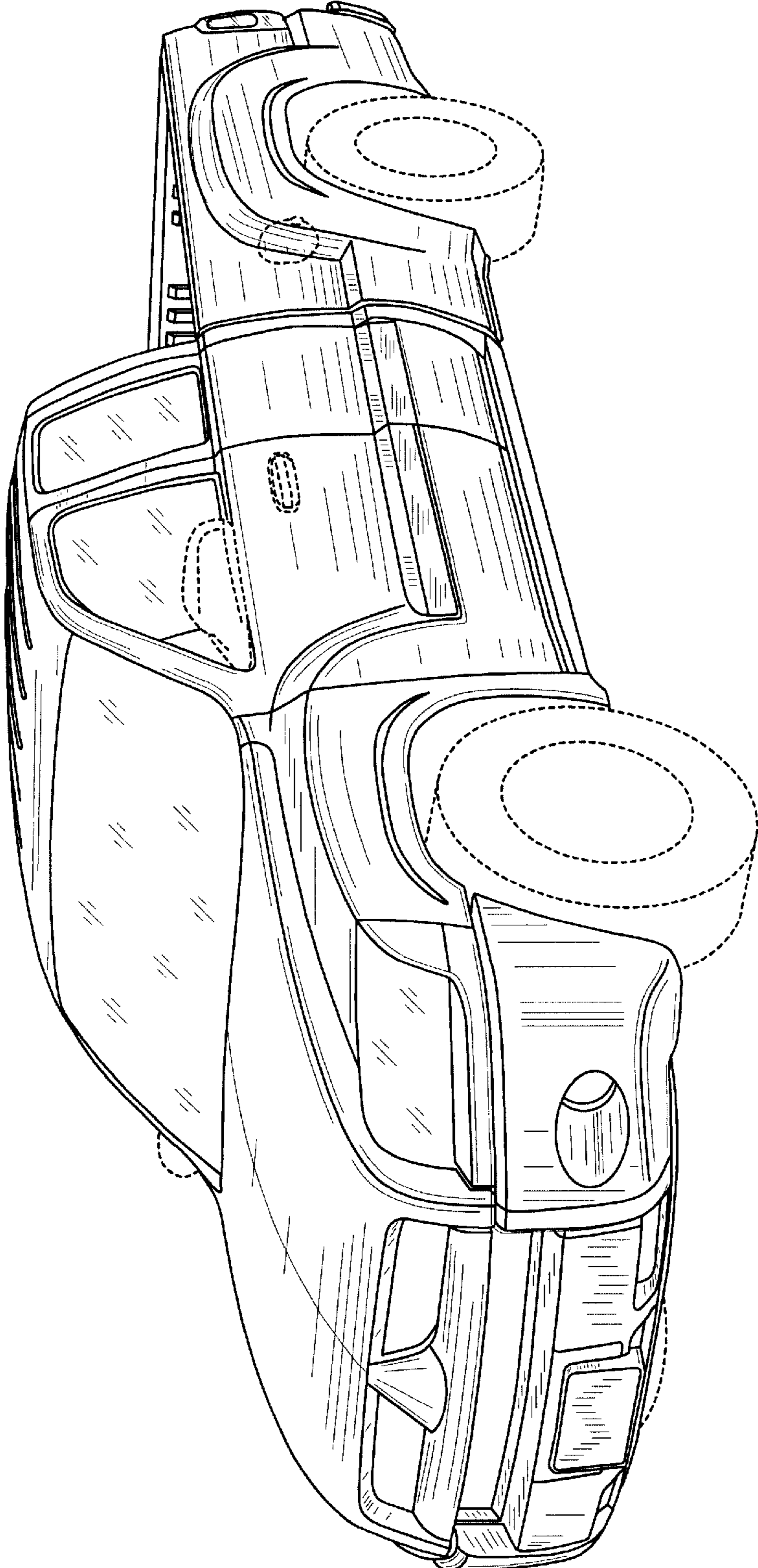

FIG. 13

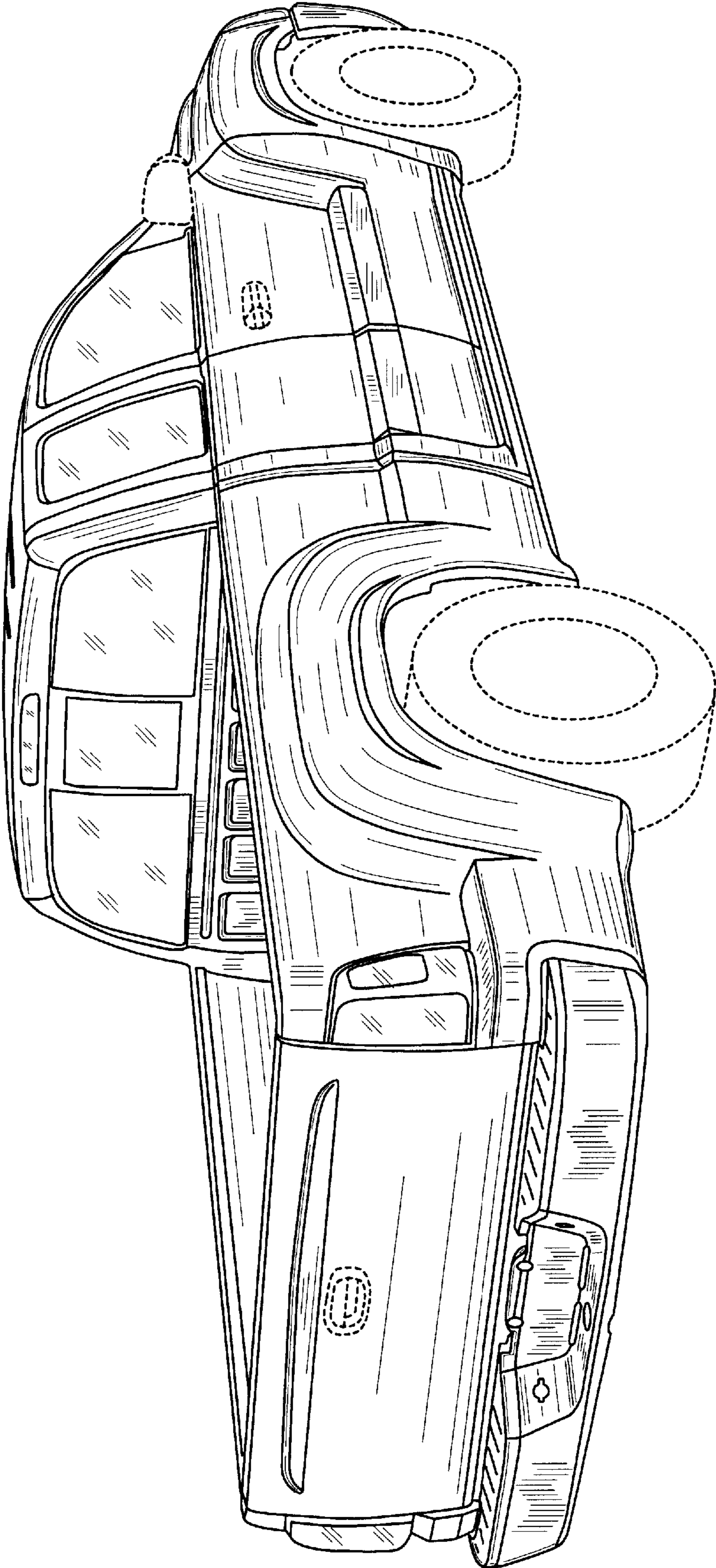

FIG. 14