



US00D515463S

(12) **United States Design Patent**
Hull

(10) **Patent No.:** **US D515,463 S**
(45) **Date of Patent:** **** Feb. 21, 2006**

(54) **TRAILER FOR CARRYING A MOTORCYCLE**

D434,701 S * 12/2000 Patmont D12/101
6,612,389 B1 * 9/2003 Bell 180/209

(75) Inventor: **Curtis Hull**, Clarinda, IA (US)

* cited by examiner

(73) Assignee: **H & H Trailer Company, Inc.**,
Clarinda, IA (US)

Primary Examiner—Melody N. Brown

(74) *Attorney, Agent, or Firm*—Wm. Bruce Day

(**) Term: **14 Years**

(57) **CLAIM**

The ornamental design for a trailer for carrying a motorcycle, as shown and described.

(21) Appl. No.: **29/185,902**

(22) Filed: **Jul. 3, 2003**

DESCRIPTION

(51) **LOC (8) Cl.** **12-10**

FIG. 1 is a side elevational view of a trailer for carrying a motorcycle.

(52) **U.S. Cl.** **D12/101**

FIG. 2 is a top plan view of the trailer.

(58) **Field of Classification Search** D12/101,

D12/102, 105; 280/475, 656, 763.1, 482,

280/462; 296/181, 190; D15/27

FIG. 3 is a rear elevational view of the trailer.

FIG. 4 is a front elevational view of the trailer.

FIG. 5 is a perspective view of the trailer; and,

FIG. 6 is a perspective view of the trailer folded upright for storage.

See application file for complete search history.

(56) **References Cited**

U.S. PATENT DOCUMENTS

3,970,203 A * 7/1976 Watson, Jr. 414/538

D336,869 S * 6/1993 Leib et al. D12/101

D369,328 S * 4/1996 Acosta D12/101

D375,921 S * 11/1996 Kunkle D12/101

The ornamental design is the configuration of the trailer including a ramp mounted to the trailer rear to enable loading of a motorcycle. In transit, the ramp is stored on the trailer. The rear portion folds for upright storage.

1 Claim, 2 Drawing Sheets

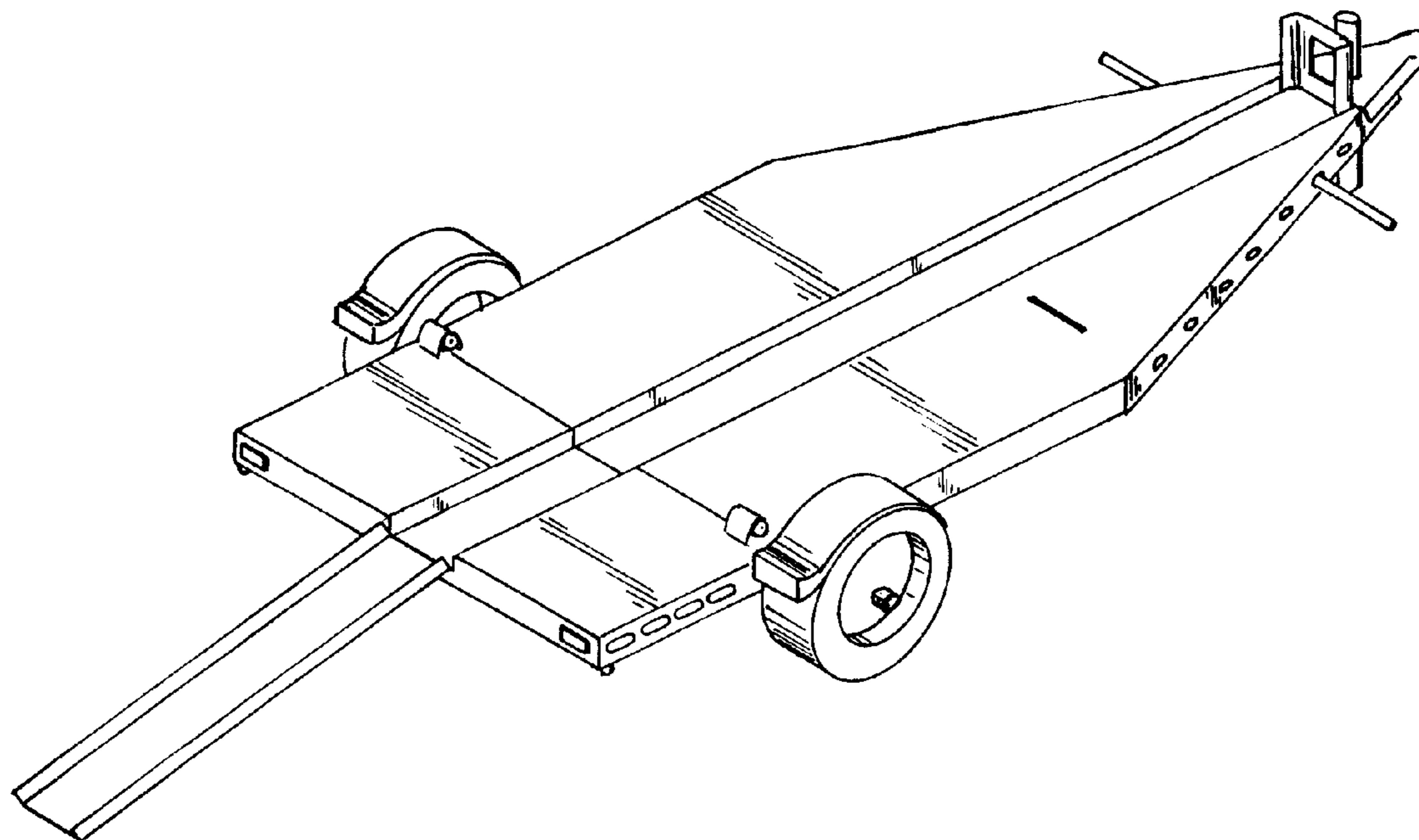

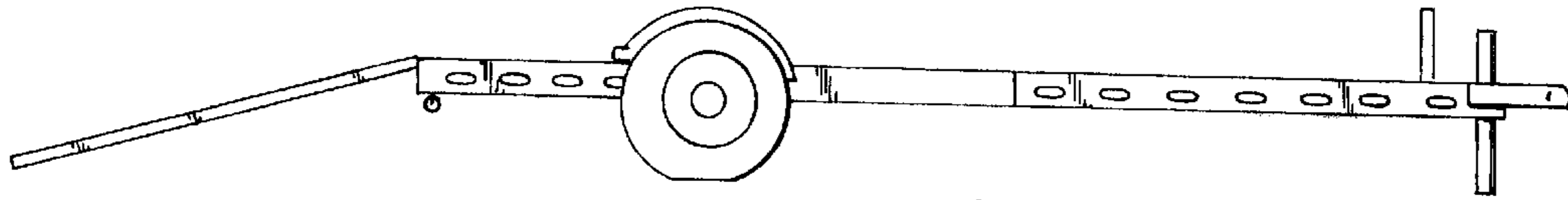

Fig. 1

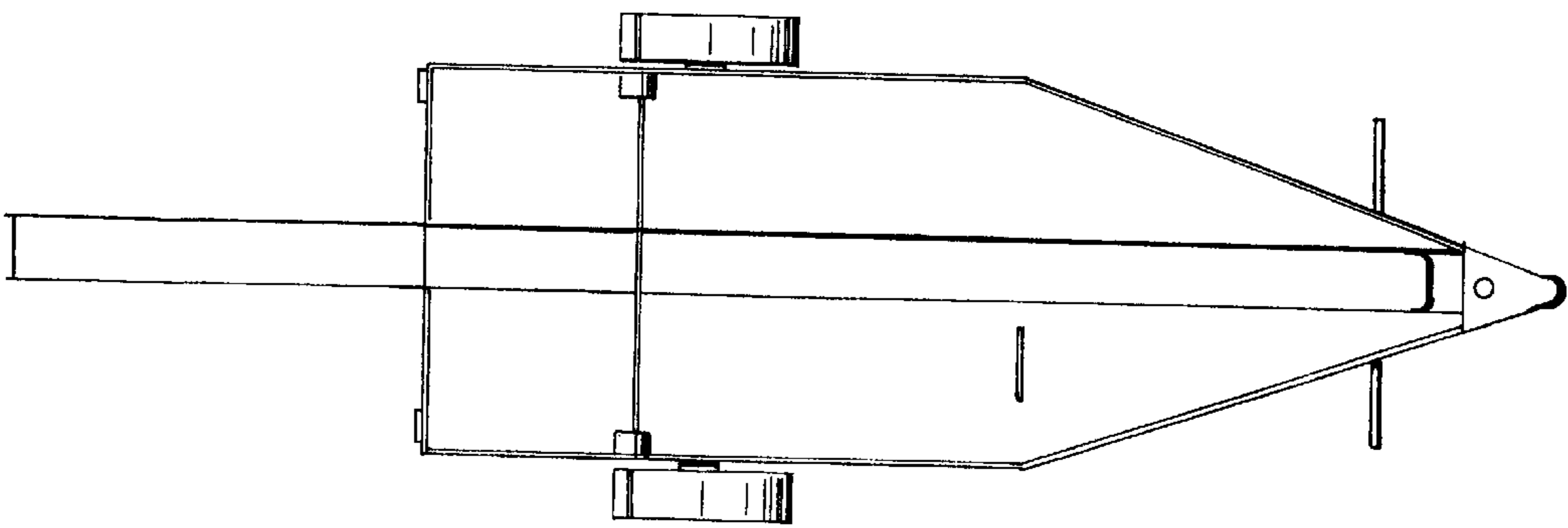

Fig. 2

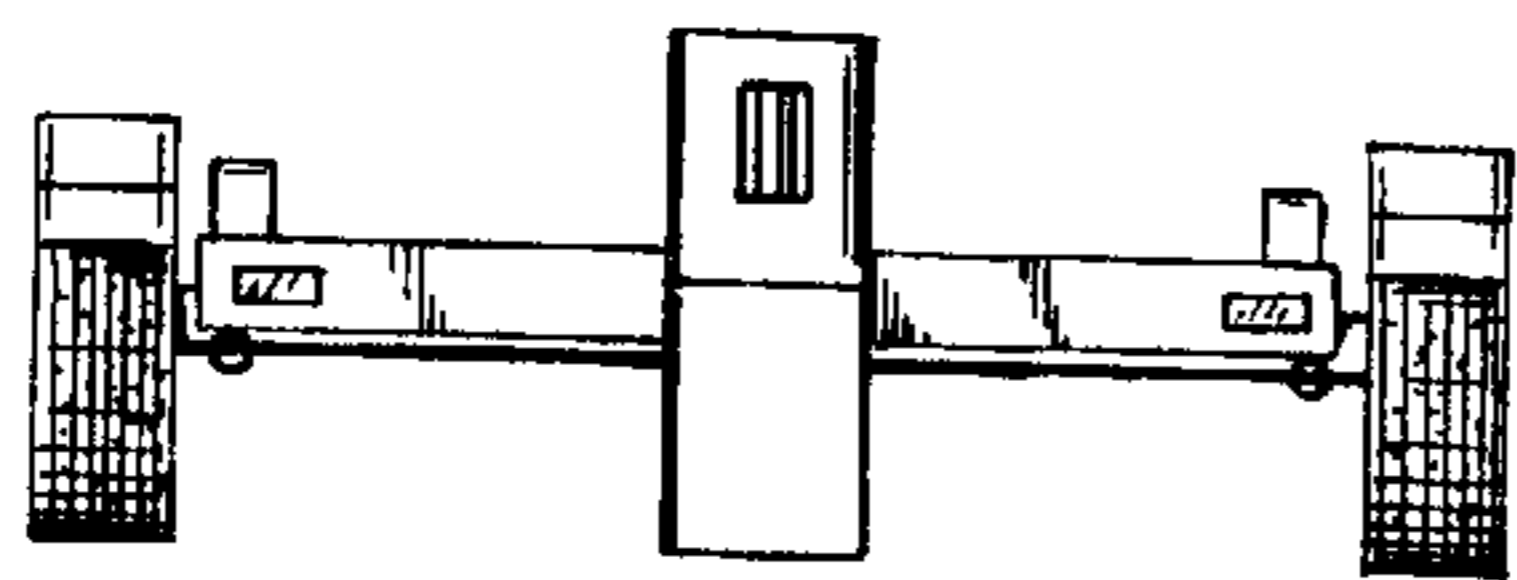

Fig. 3

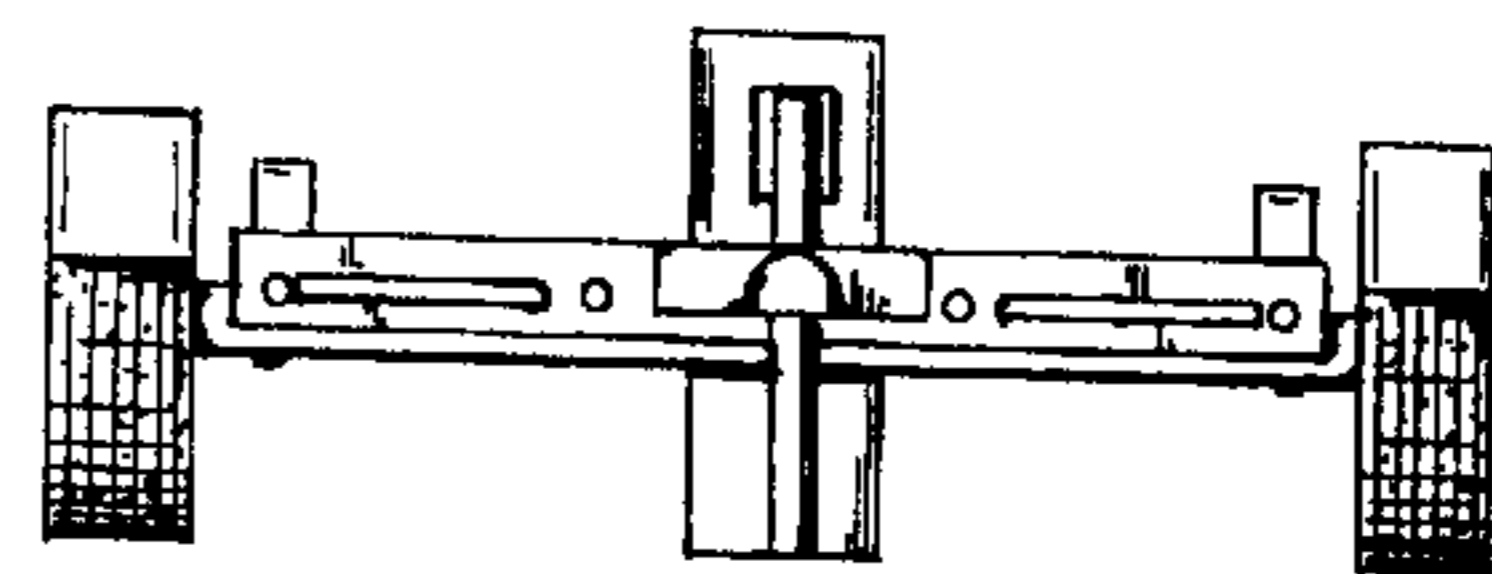

Fig. 4

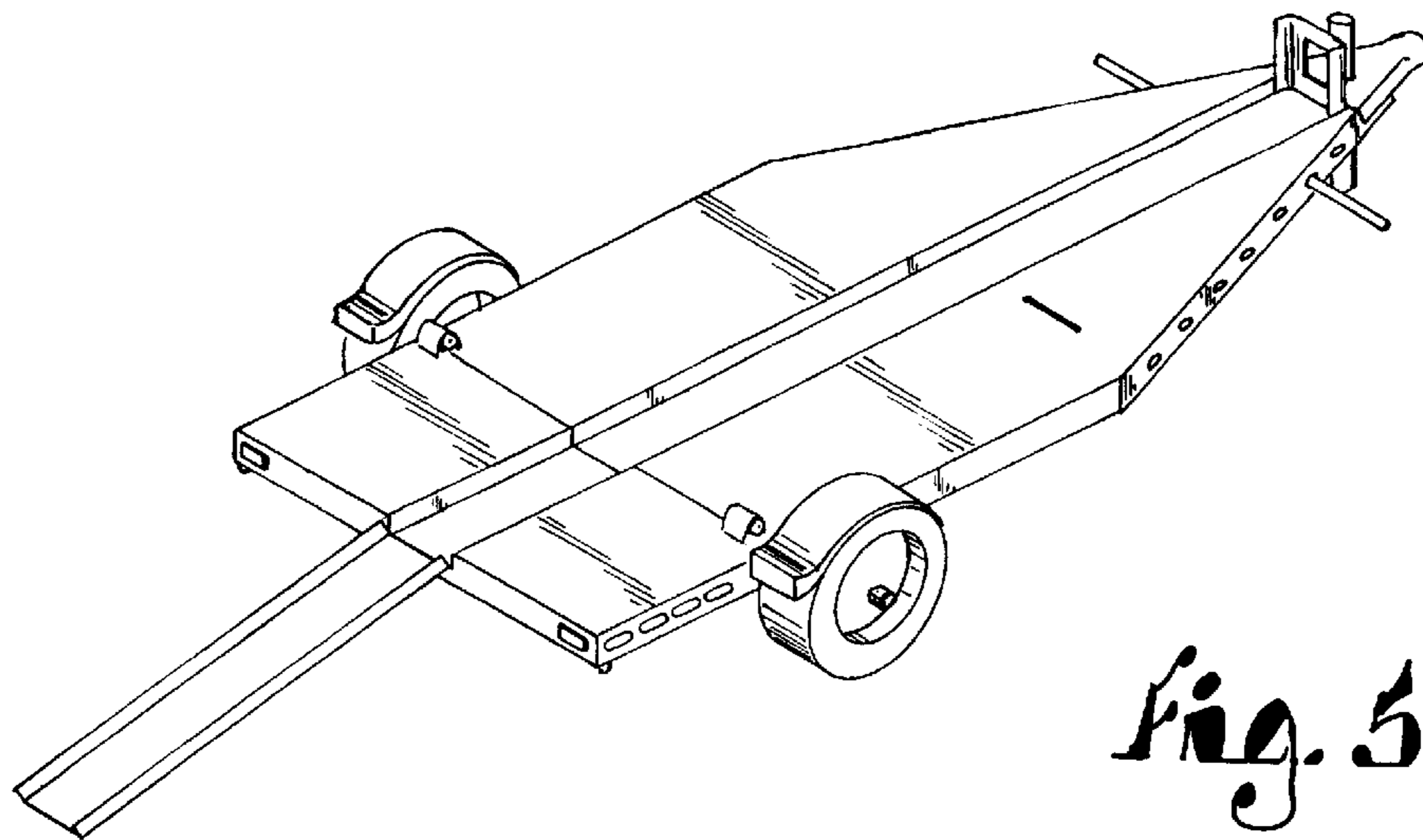

Fig. 5

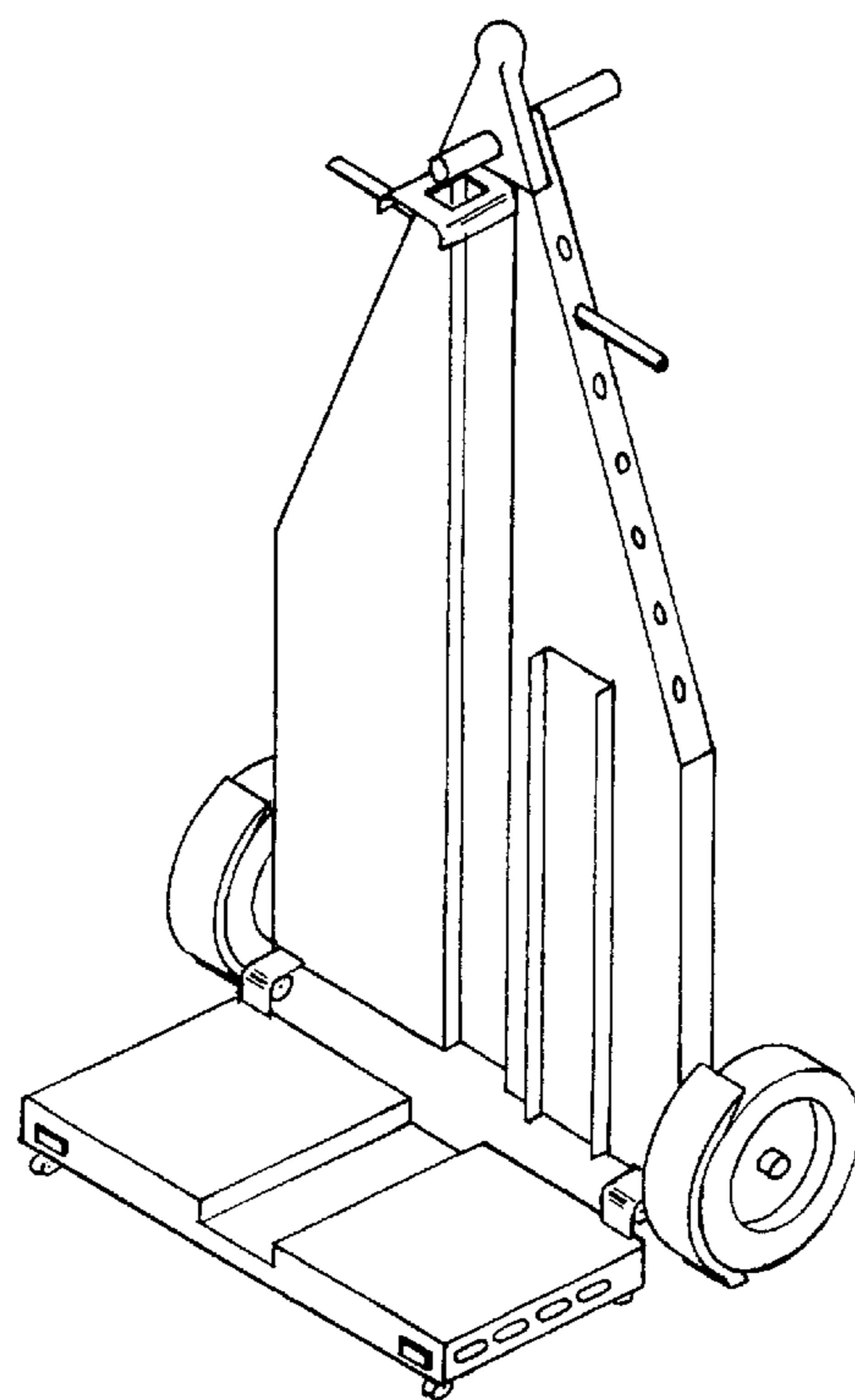

Fig. 6