



US00D515462S

(12) **United States Design Patent** (10) **Patent No.:** **US D515,462 S**  
**Metros et al.** (45) **Date of Patent:** **\*\* Feb. 21, 2006**

(54) **PICK UP TRUCK**

D500,461 S \* 1/2005 Noguchi et al. .... D12/98

(75) Inventors: **Craig Metros**, Bloomfield, MI (US);  
**Patrick J. Schiavone**, Birmingham, MI  
(US); **Tyler Jon Blake**, Dearborn, MI  
(US); **Jeffery Nowak**, Huntington, MI  
(US)

\* cited by examiner

*Primary Examiner*—Melody N. Brown  
(74) *Attorney, Agent, or Firm*—Artz & Artz PLC; Damian  
Porcari

(73) Assignee: **Ford Global Technologies, LLC**,  
Dearborn, MI (US)

(57) **CLAIM**

The ornamental design for a pick up truck, as shown and  
described.

(\*\*) Term: **14 Years**

**DESCRIPTION**

(21) Appl. No.: **29/193,386**

FIG. 1 is a perspective view of a pick up truck in accordance  
with a preferred embodiment of the present invention;  
FIG. 2 is front view of the pick up truck of FIG. 1;  
FIG. 3 is a side view of the pick up truck of FIG. 1;  
FIG. 4 is a rear view of the pick up truck of FIG. 1;  
FIG. 5 is a top view of the pick up truck of FIG. 1; and,  
FIG. 6 is another perspective view of the pick up truck of  
FIG. 1.

(22) Filed: **Nov. 7, 2003**

(51) **LOC (8) Cl.** ..... **12-08**

(52) **U.S. Cl.** ..... **D12/98**

(58) **Field of Classification Search** ..... D12/98,  
D12/93; 296/185, 186, 181.1–183.1  
See application file for complete search history.

The bottom view of the vehicle is not part of the claimed  
design. The sides of the vehicle are mirror images of one  
another. The broken lines, including for the tires, the head-  
lamps, the tail lamps, the mirrors, the running boards, the  
handles, and the grill illustrate the environment of the design  
and are not part of the claimed design.

(56) **References Cited**

**U.S. PATENT DOCUMENTS**

- D430,068 S \* 8/2000 Castiglione et al. .... D12/98
- D474,716 S \* 5/2003 Wakao ..... D12/98
- D479,158 S \* 9/2003 Hayashi et al. .... D12/98
- D494,105 S \* 8/2004 Hall et al. .... D12/98
- D495,626 S \* 9/2004 Depeyster et al. .... D12/98

**1 Claim, 3 Drawing Sheets**

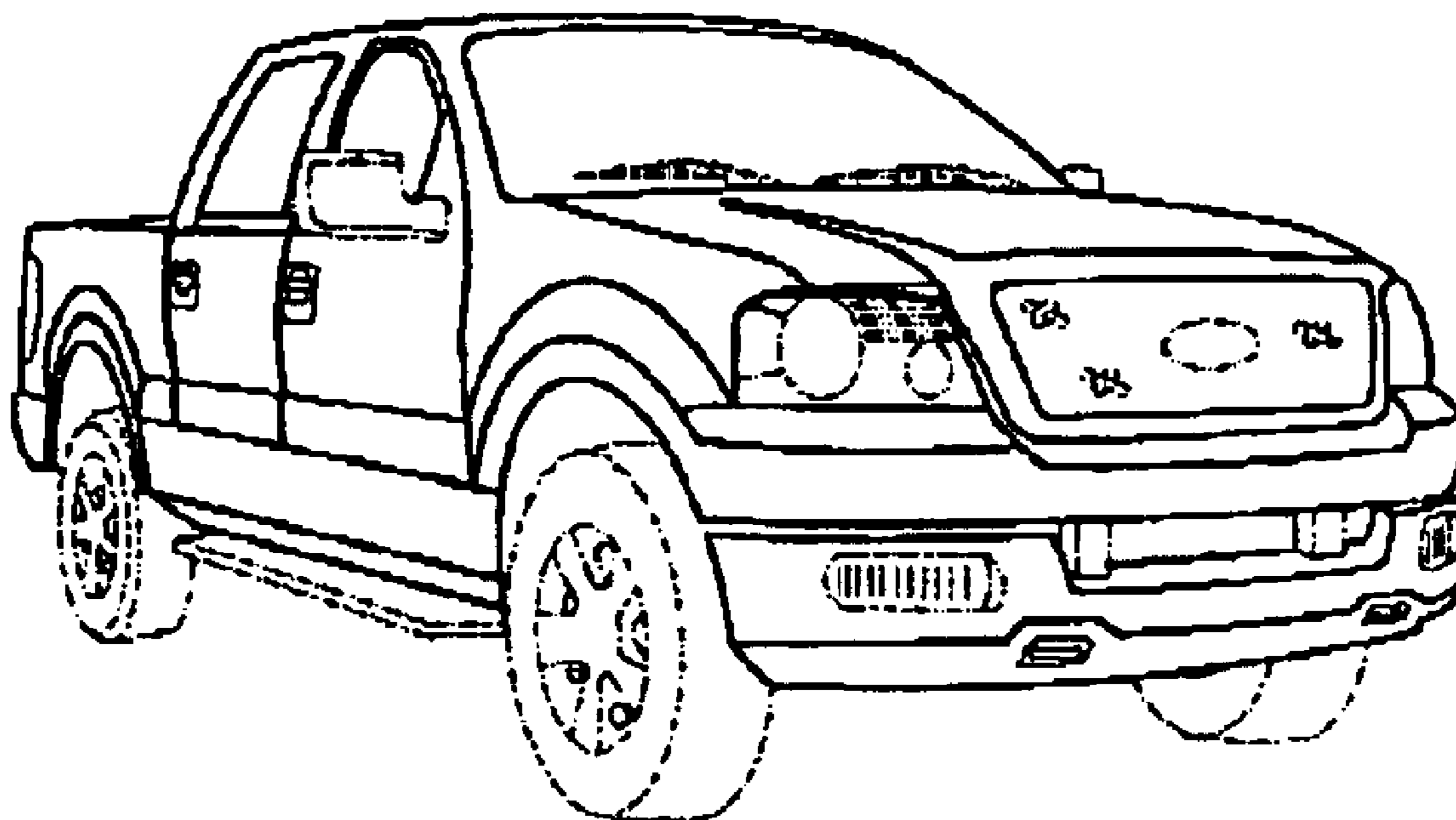

Figure 1

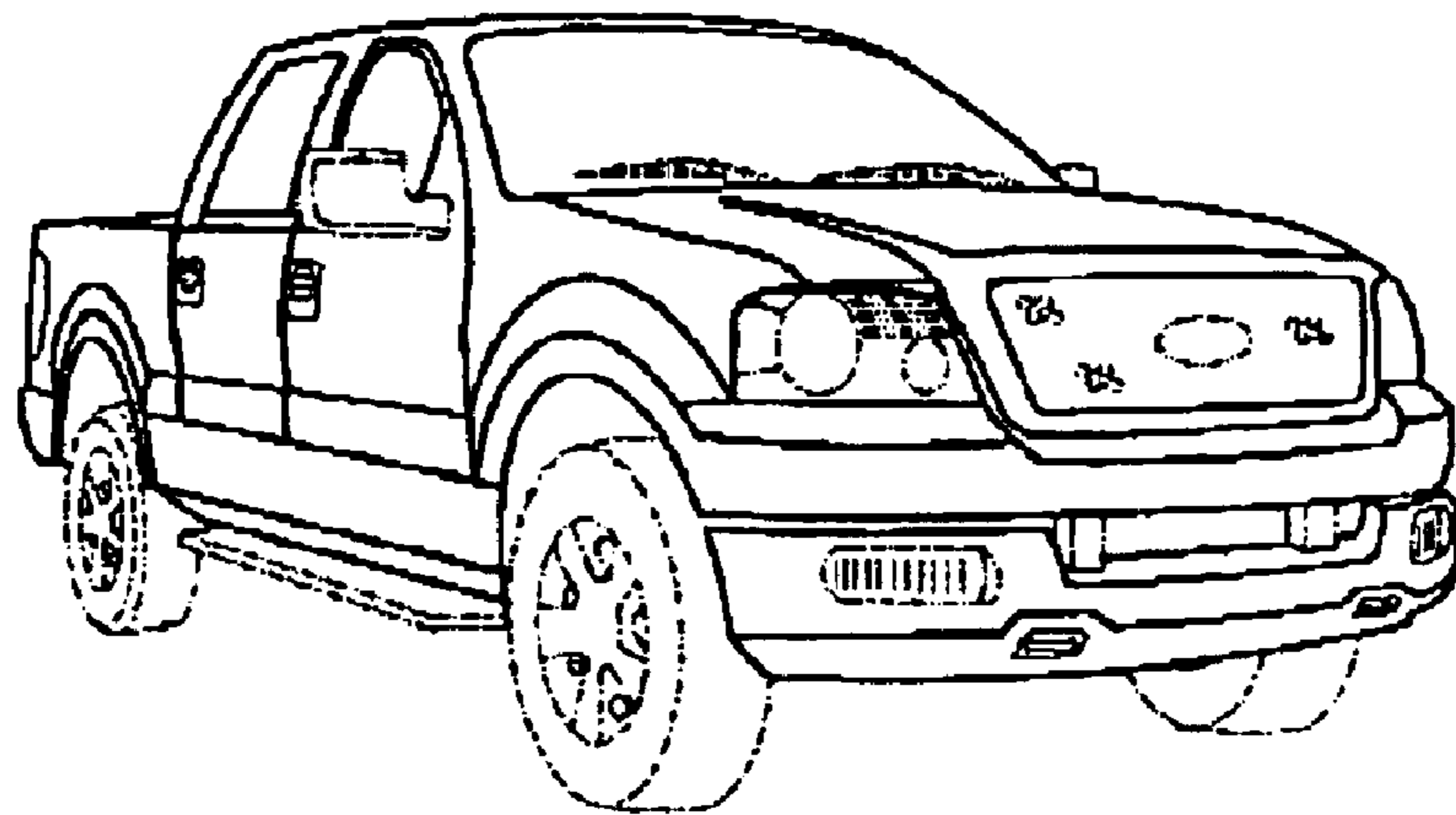

Figure 2

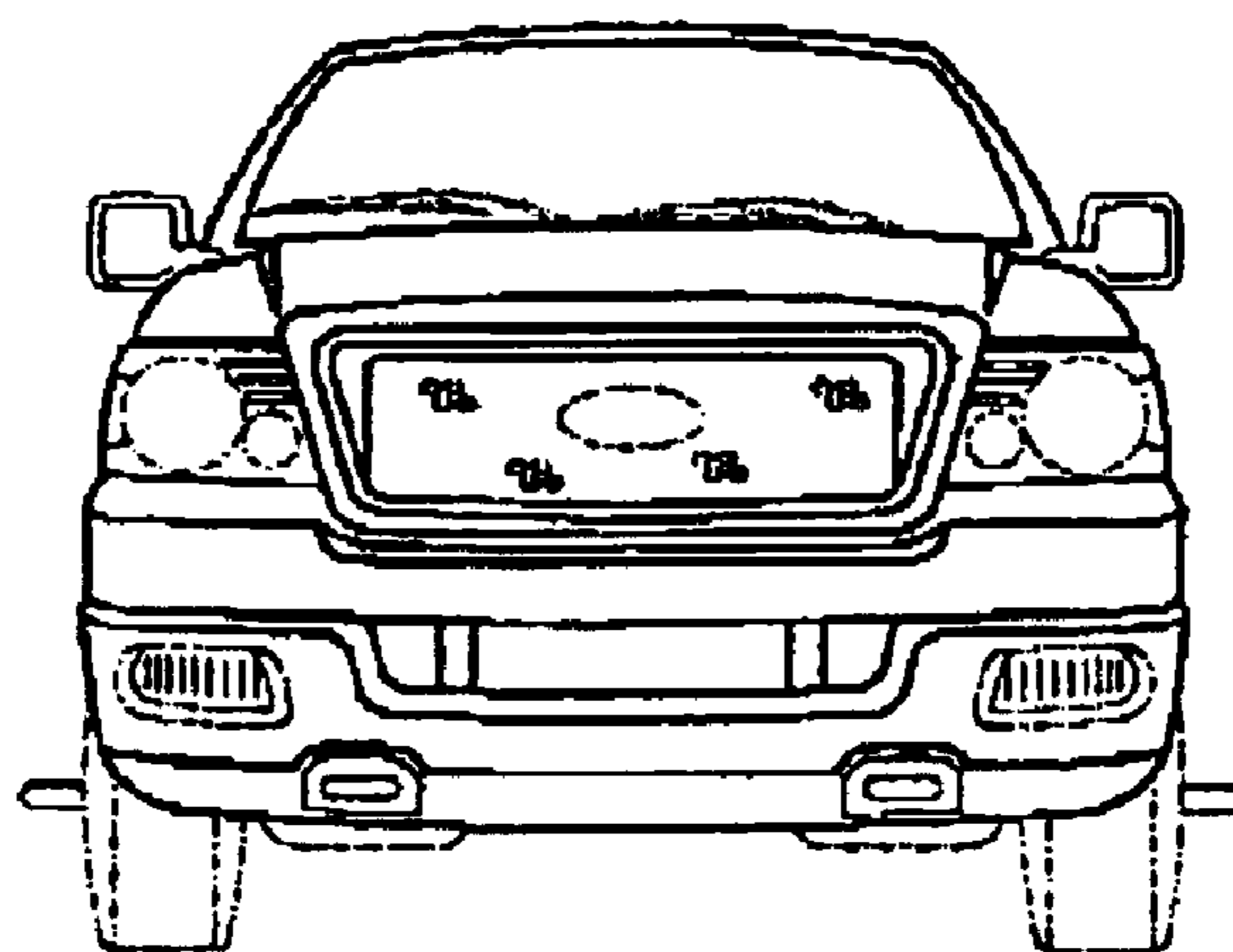

Figure 3

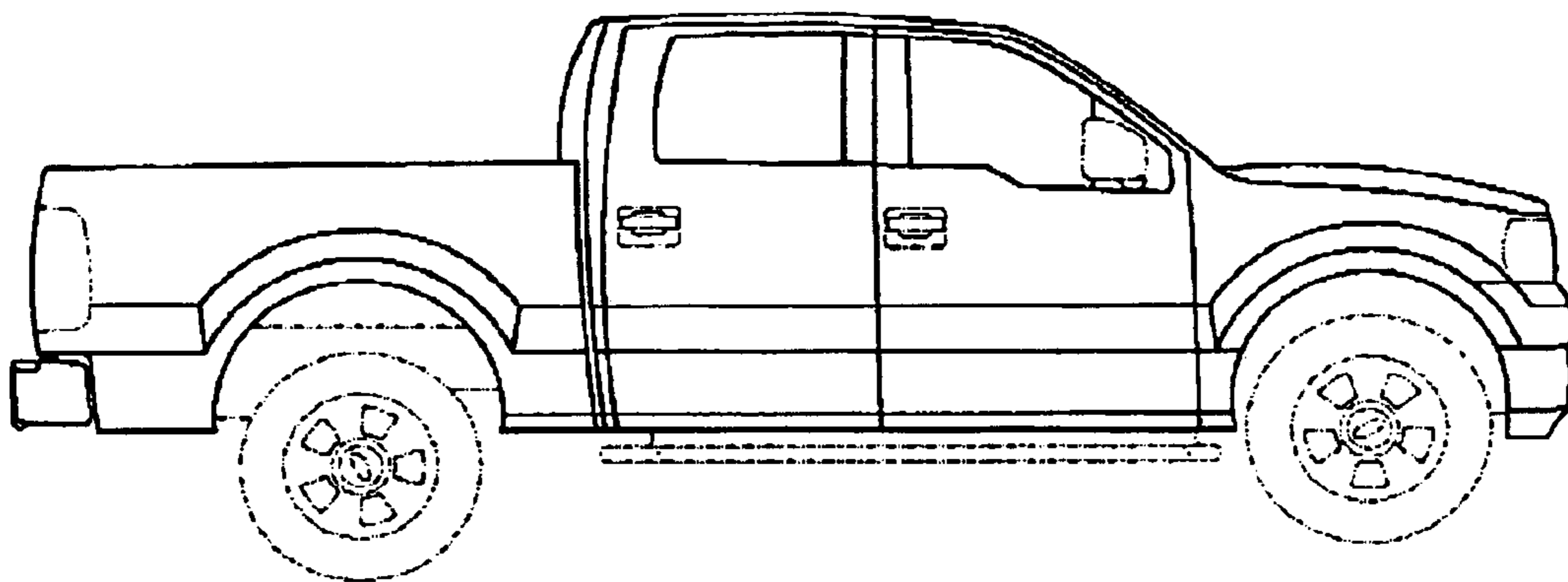

Figure 4

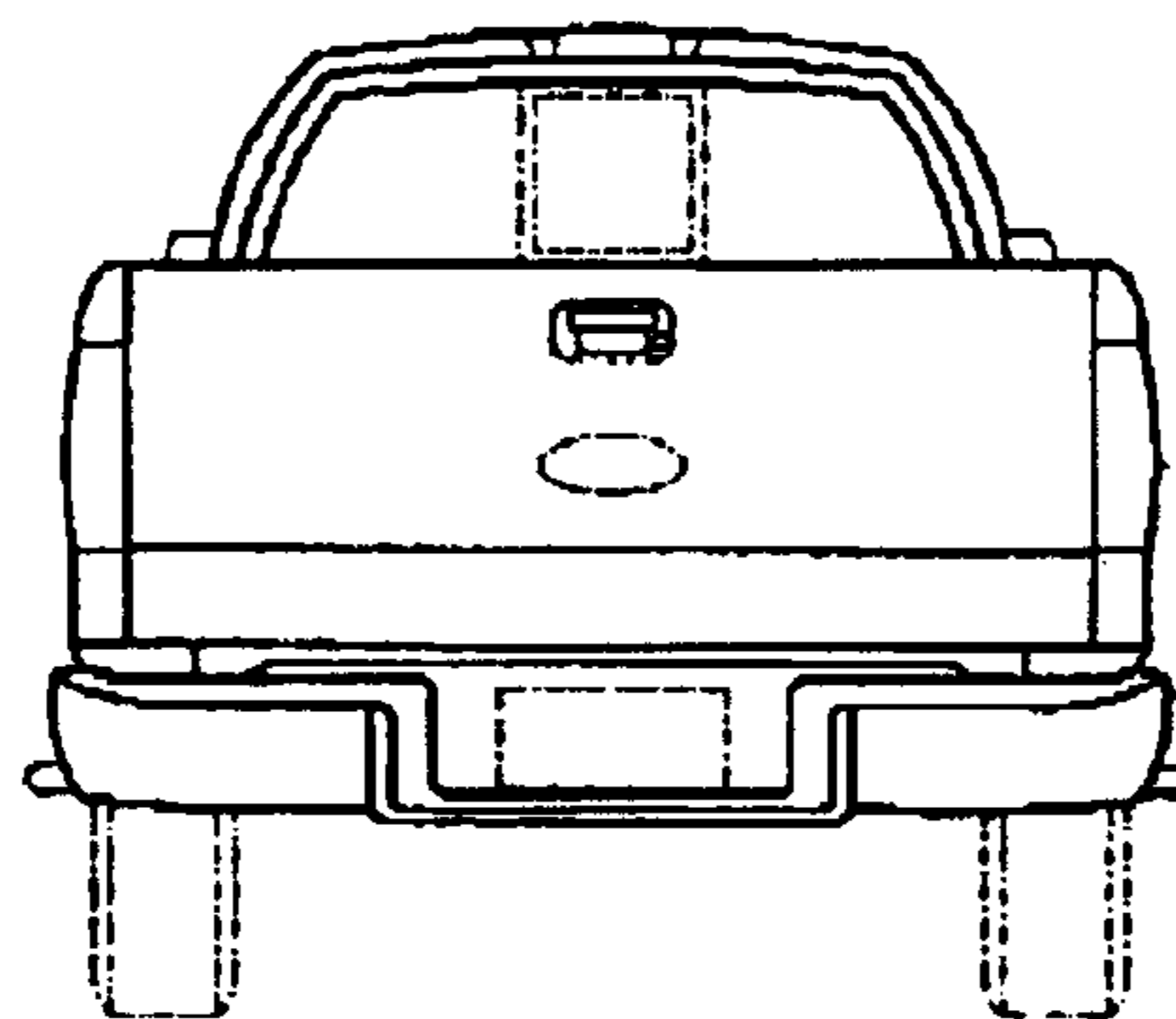

Figure 5

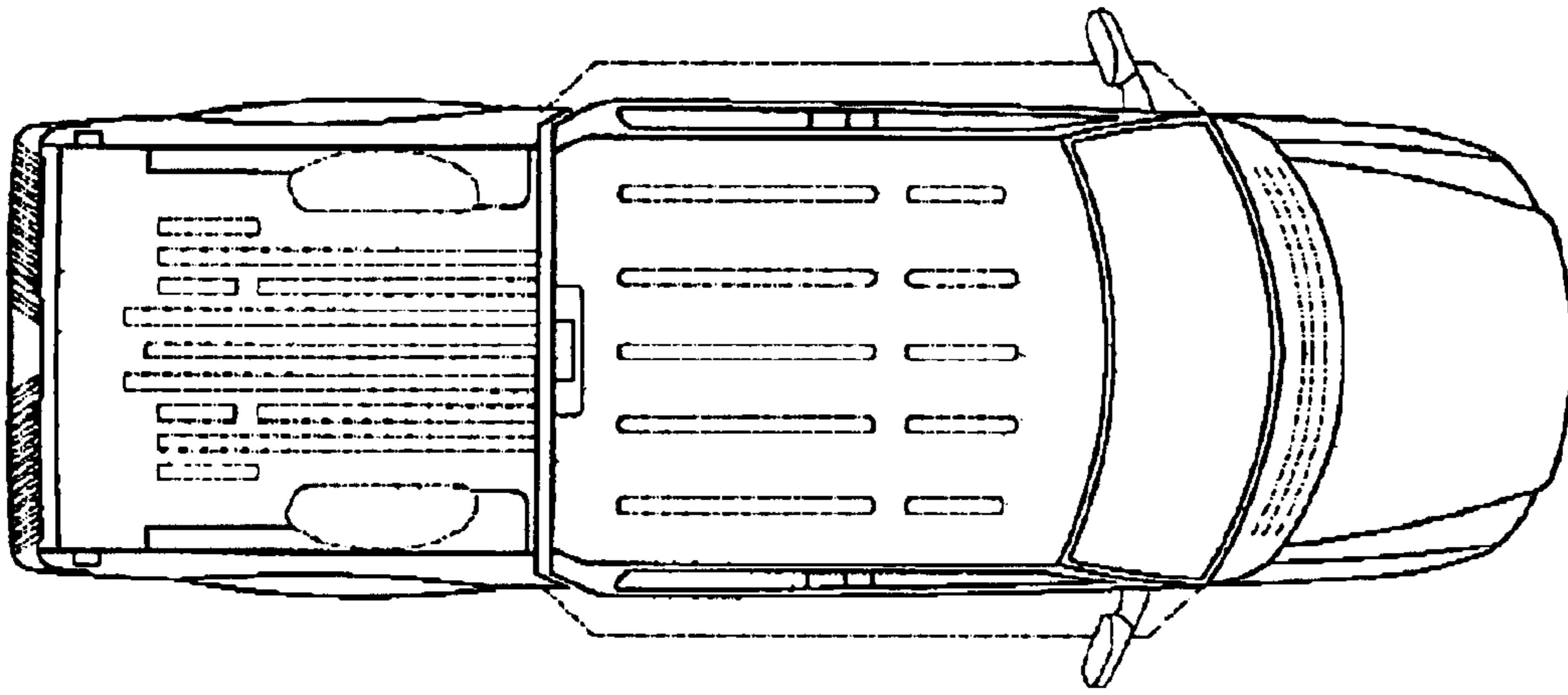

Figure 6

