



US00D515222S

(12) **United States Design Patent** (10) **Patent No.:** **US D515,222 S**
Kieffer (45) **Date of Patent:** **** Feb. 14, 2006**

(54) **OCTOPOST EXTRUSION**

5,490,532 A 2/1996 Mallookis et al.
5,584,564 A 12/1996 Phyle

(75) Inventor: **Stephen George Kieffer**, Washington Island, WI (US)

FOREIGN PATENT DOCUMENTS

(73) Assignee: **Kieffer & Co., Inc.**, Sheboygan, WI (US)

FR 1 303 185 7/1961
GB 665244 1/1952

(**) Term: **14 Years**

* cited by examiner

(21) Appl. No.: **29/113,106**

Primary Examiner—Doris Clark
(74) *Attorney, Agent, or Firm*—Oblon, Spivak, McClelland, Maier & Neustadt, P.C.

(22) Filed: **Nov. 1, 1999**

(57) **CLAIM**

(51) **LOC (8) Cl.** **25-01**

The ornamental design for octopost extrusion, as shown and described.

(52) **U.S. Cl.** **D25/122**

(58) **Field of Classification Search** D25/121–122,
D25/126, 61; 52/720.1, 730.4, 731.2, 732.1,
52/737.6; 135/127, 114, 120.3, 121; 229/109
See application file for complete search history.

DESCRIPTION

(56) **References Cited**

U.S. PATENT DOCUMENTS

223,468 A	1/1880	Benthall	
928,495 A	7/1909	Busenbark	
1,563,736 A	12/1925	Fink	
1,593,431 A	7/1926	Buie	
2,333,915 A	11/1943	Budd	
2,618,285 A	11/1952	Heisig	
2,845,078 A	7/1958	Singleton	
3,383,127 A	5/1968	Grunfeld	
4,408,260 A	10/1983	Miedel	
4,745,863 A	* 5/1988	Takezaki	101/426
4,825,890 A	5/1989	Castlebury	
4,941,500 A	7/1990	Emard	
5,053,931 A	10/1991	Rushing	
5,144,780 A	9/1992	Gieling et al.	
5,185,972 A	2/1993	Markiewicz	
5,438,717 A	8/1995	Wells	

The design is directed to an aluminum extrusion performing an octagon shaped structural element of unequal sides to provide structural strength substantially equivalent to a square-shaped member while providing an aesthetically pleasing appearance. The corners of the extrusion are formed with a slight radius and the extrusion can be utilized as a structural element of aluminum fabrications so as to be visible upon completion of the fabrication. As an example, such can be used in the construction of a canopy shelter. FIG. 1 is a top, left front perspective view of octopost extrusion showing my new design; FIG. 2 is a front elevational view thereof; FIG. 3 is a top plan view thereof; FIG. 4 is a bottom plan view thereof; and, FIG. 5 is a right side elevational view thereof, the left side view being a mirror image of the right side view shown. The broken line showing in the figures is for illustrative purposes only and forms no part of the claimed design.

1 Claim, 3 Drawing Sheets

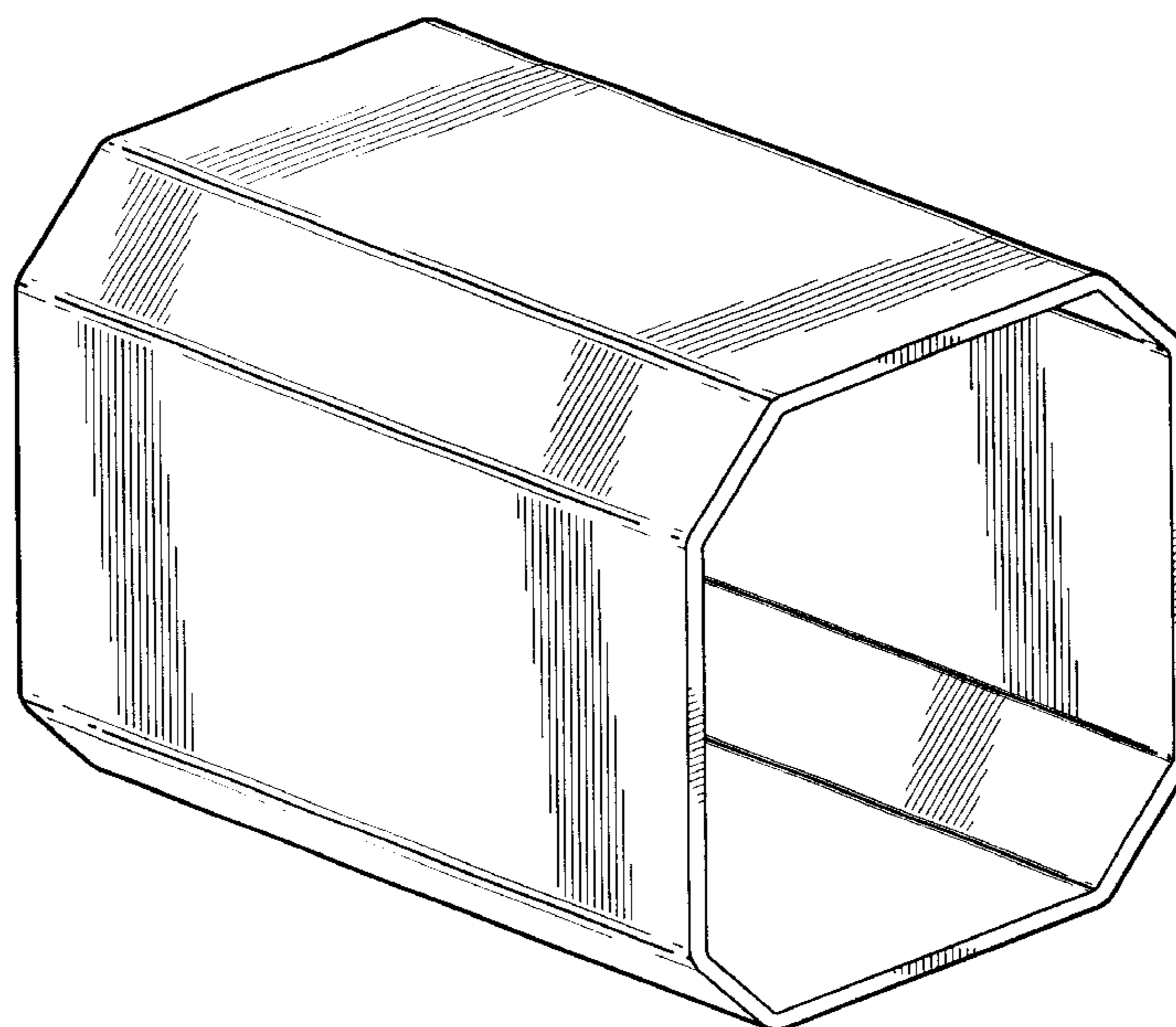

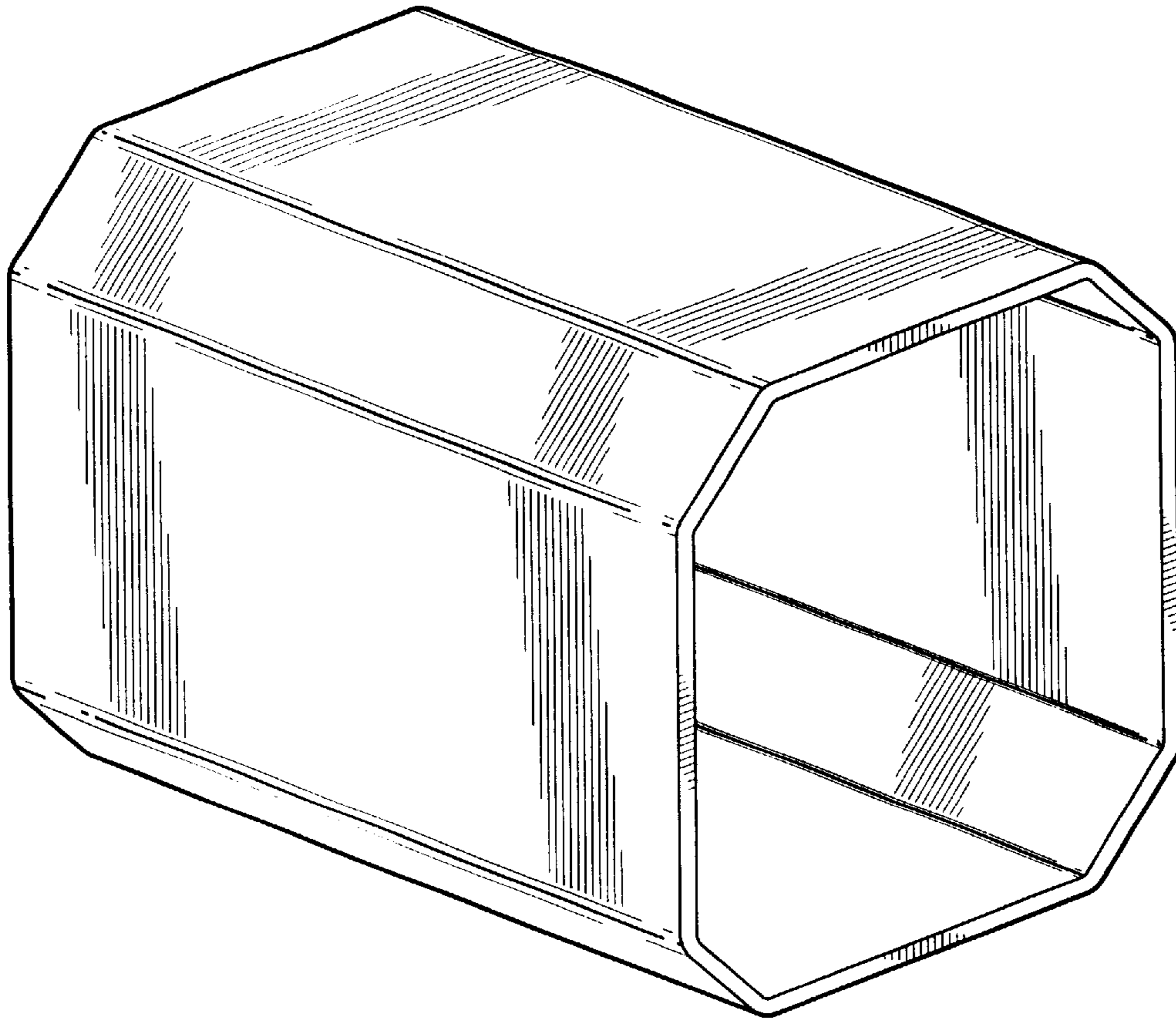

FIG. 1

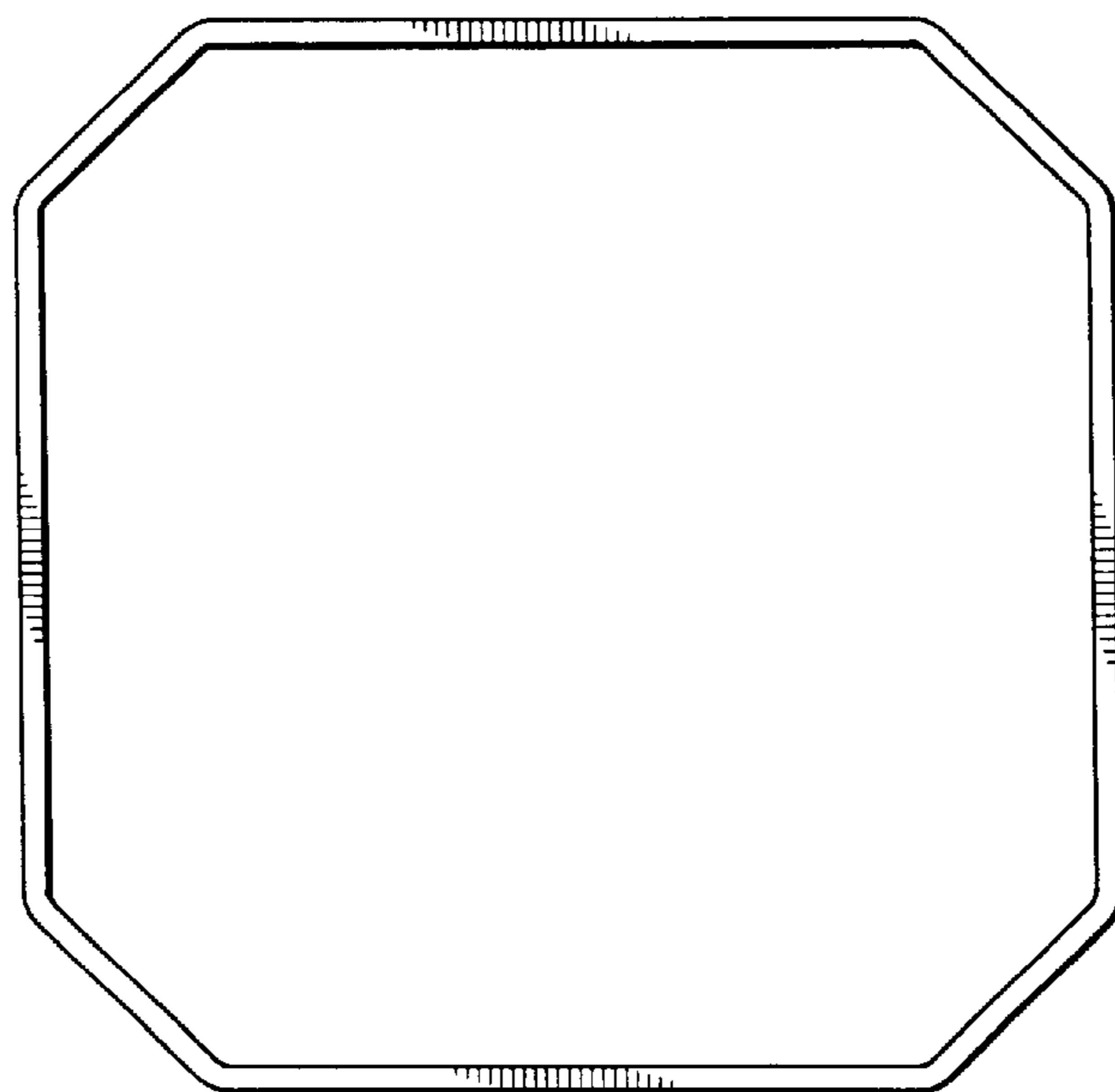

FIG. 2

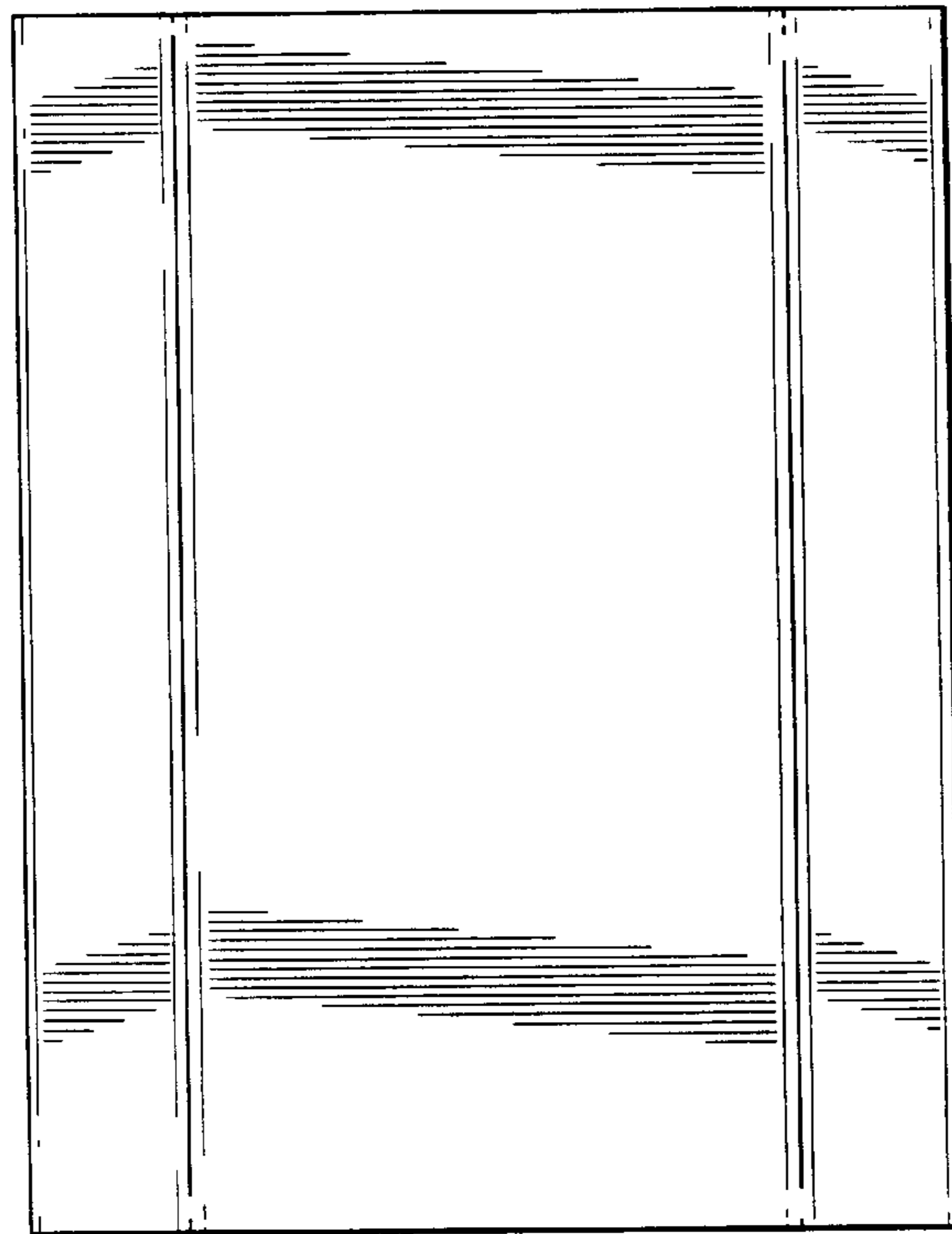

FIG. 3

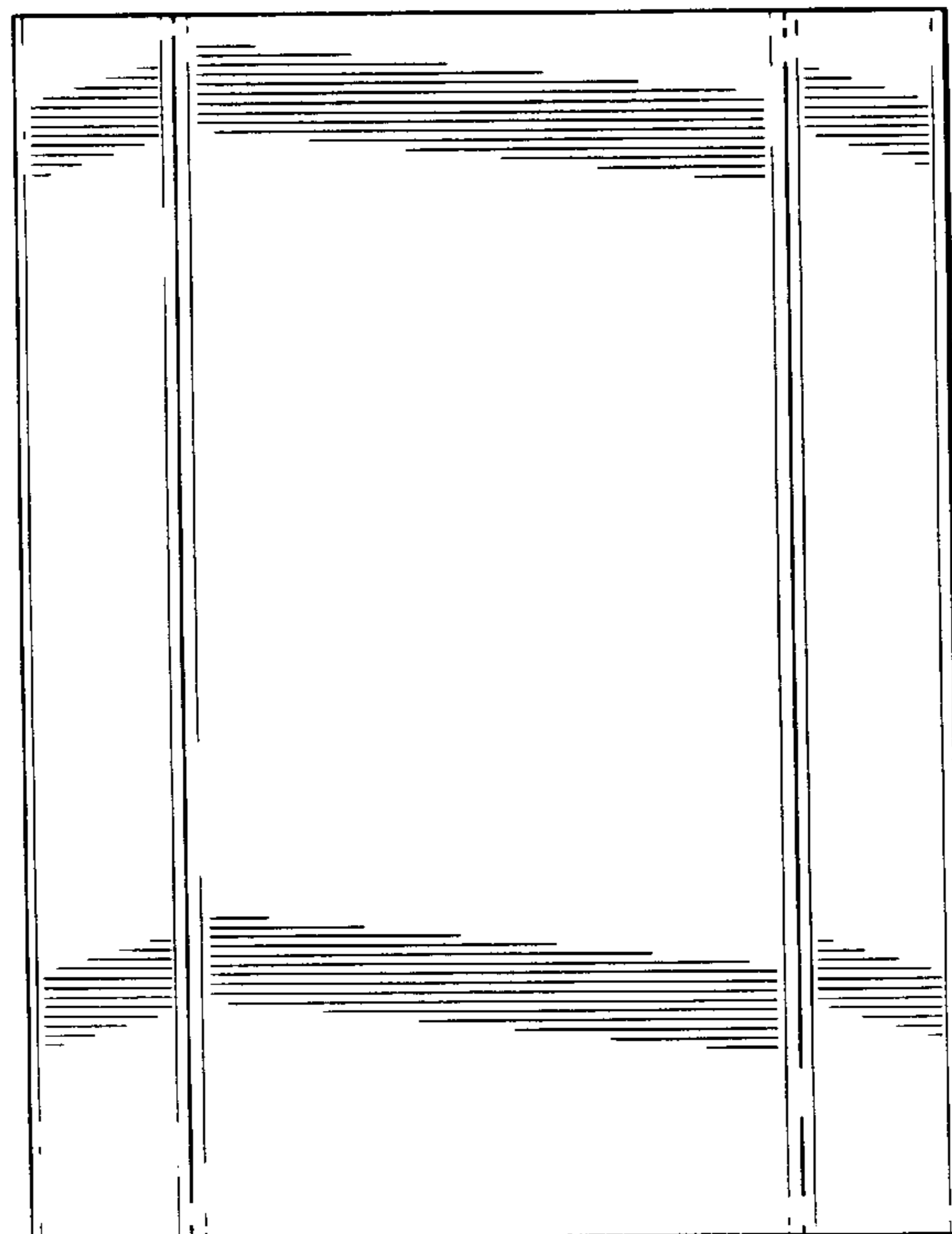

FIG. 4

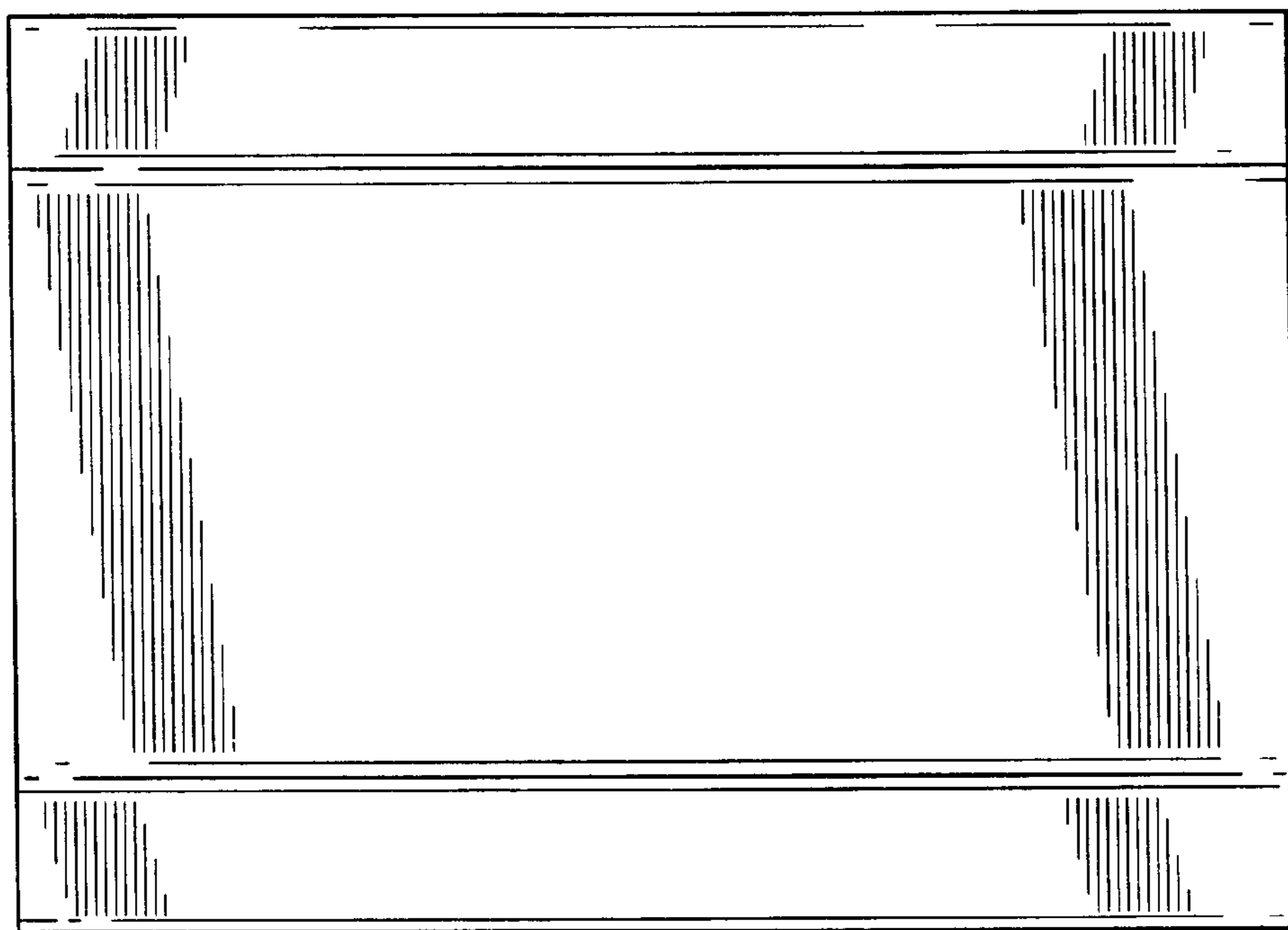

FIG. 5