



US00D515152S

(12) **United States Design Patent** (10) **Patent No.:** **US D515,152 S**
Corbalis et al. (45) **Date of Patent:** **** Feb. 14, 2006**

(54) **RECUMBENT BICYCLE**

(75) Inventors: **Kevin Patrick Corbalis**, Tustin, CA (US); **Mark William Chiles**, Yorba Linda, CA (US); **Victor Torres Cornejo**, Tustin, CA (US); **Jirawat O. Jeanvigite**, Los Angeles, CA (US); **John Cook**, Ventura, CA (US)

(73) Assignee: **Unisen, Inc.**, Irvine, CA (US)

(**) Term: **14 Years**

(21) Appl. No.: **29/190,275**

(22) Filed: **Sep. 17, 2003**

(51) **LOC (8) Cl.** **21-02**

(52) **U.S. Cl.** **D21/666**

(58) **Field of Classification Search** D21/663,
D21/664, 665, 666, 667, 668; 482/51, 52,
482/53, 57, 58, 59

See application file for complete search history.

(56) **References Cited**

U.S. PATENT DOCUMENTS

D320,826 S	*	10/1991	Hildebrandt et al.	D21/666
D342,299 S	*	12/1993	Birrell et al.	D21/666
D347,039 S	*	5/1994	Littrell et al.	D21/666
D355,942 S	*	2/1995	Wu	D21/666
D362,699 S	*	9/1995	Heaton et al.	D21/666
5,690,582 A		11/1997	Ulrich et al.	
5,890,995 A		4/1999	Bobick et al.	
6,001,046 A		12/1999	Chang	
D439,289 S	*	3/2001	Moran et al.	D21/666
D461,210 S	*	8/2002	Fon	D21/666

OTHER PUBLICATIONS

Website page of Tunturi Recumbent Cycle F 570; <http://web.archive.org/web/19970418121321/www.tunturi.com/f570.html>.

Website page of Tunturi F520; http://web.archive.org/web/20010430051355/www.tunturi.com/php/fitness.php?tr_id=7&tuote_id=112.

Digital Image of Tunturi F520 2001.

Cycling in a Recumbent Position, National Fitness Trade Journal, Fall, 1998, Author: Dennis Michaelson, pp. 18 & 19.

Star Track Introduces New V-Bike, National Fitness Trade Journal, Fall, 1998; pp. 22, 23,25.

* cited by examiner

Primary Examiner—Philip S. Hyder

(74) *Attorney, Agent, or Firm*—Knobbe, Martens, Olson & Bear, LLP

(57) **CLAIM**

The ornamental design for a recumbent bicycle, as shown and described.

DESCRIPTION

FIG. 1 is a top, rear perspective view of a recumbent bicycle arranged and configured in accordance with one aspect of the present invention.

FIG. 2 is a front end view of the recumbent bicycle of FIG. 1.

FIG. 3 is a rear end view of the recumbent bicycle of FIG. 1.

FIG. 4 is a right side elevational view of the recumbent bicycle of FIG. 1. The left side elevational view of the recumbent bicycle of FIG. 1 is substantially a mirror image of FIG. 1, the only difference being the position of the pedals.

FIG. 5 is a bottom view of the recumbent bicycle of FIG. 1; and,

FIG. 6 is a top view of the recumbent bicycle of FIG. 1. The elements illustrated in dashed lines in the accompanying drawings are considered environmental and do not form a part of the claimed design.

1 Claim, 4 Drawing Sheets

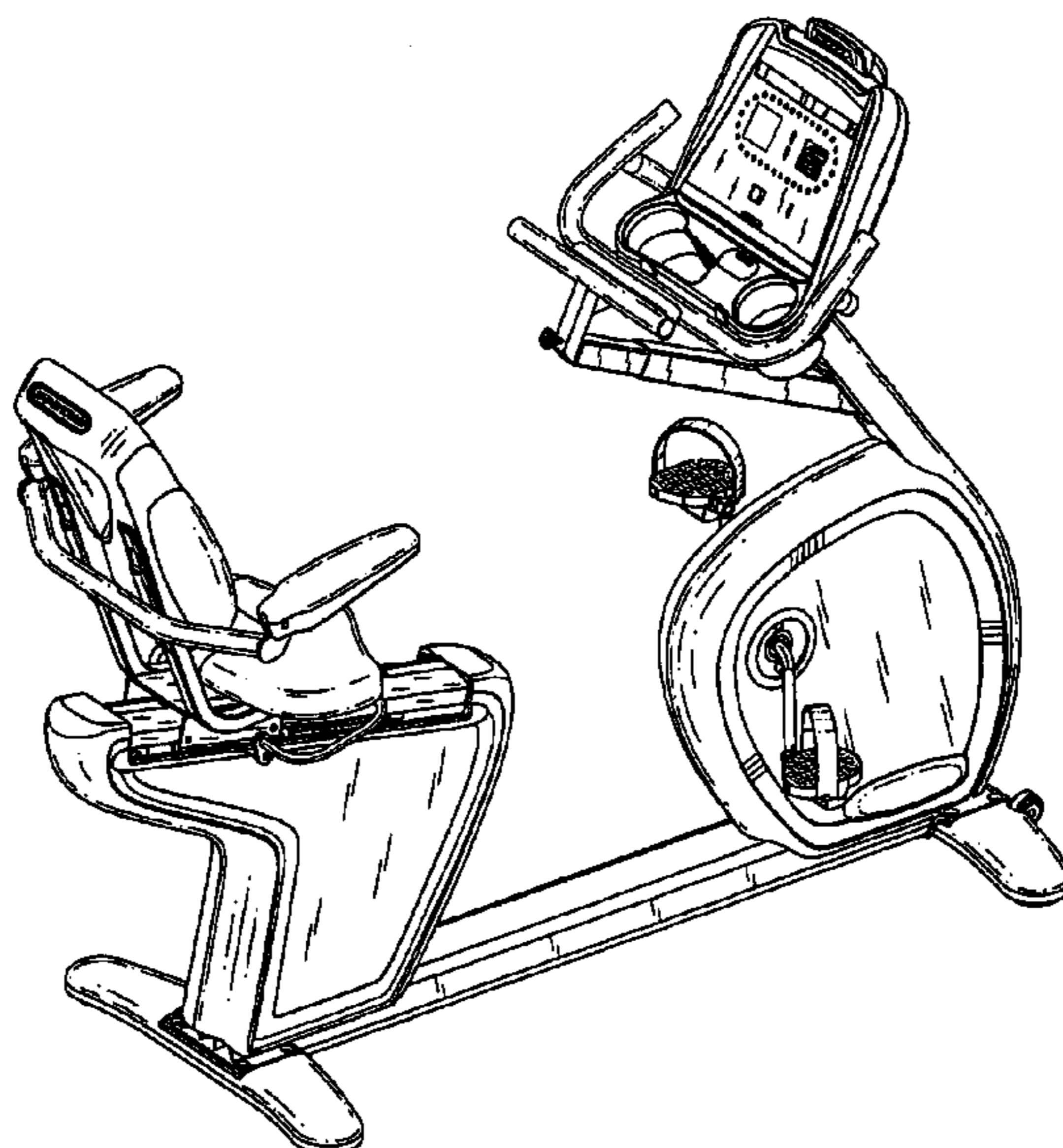

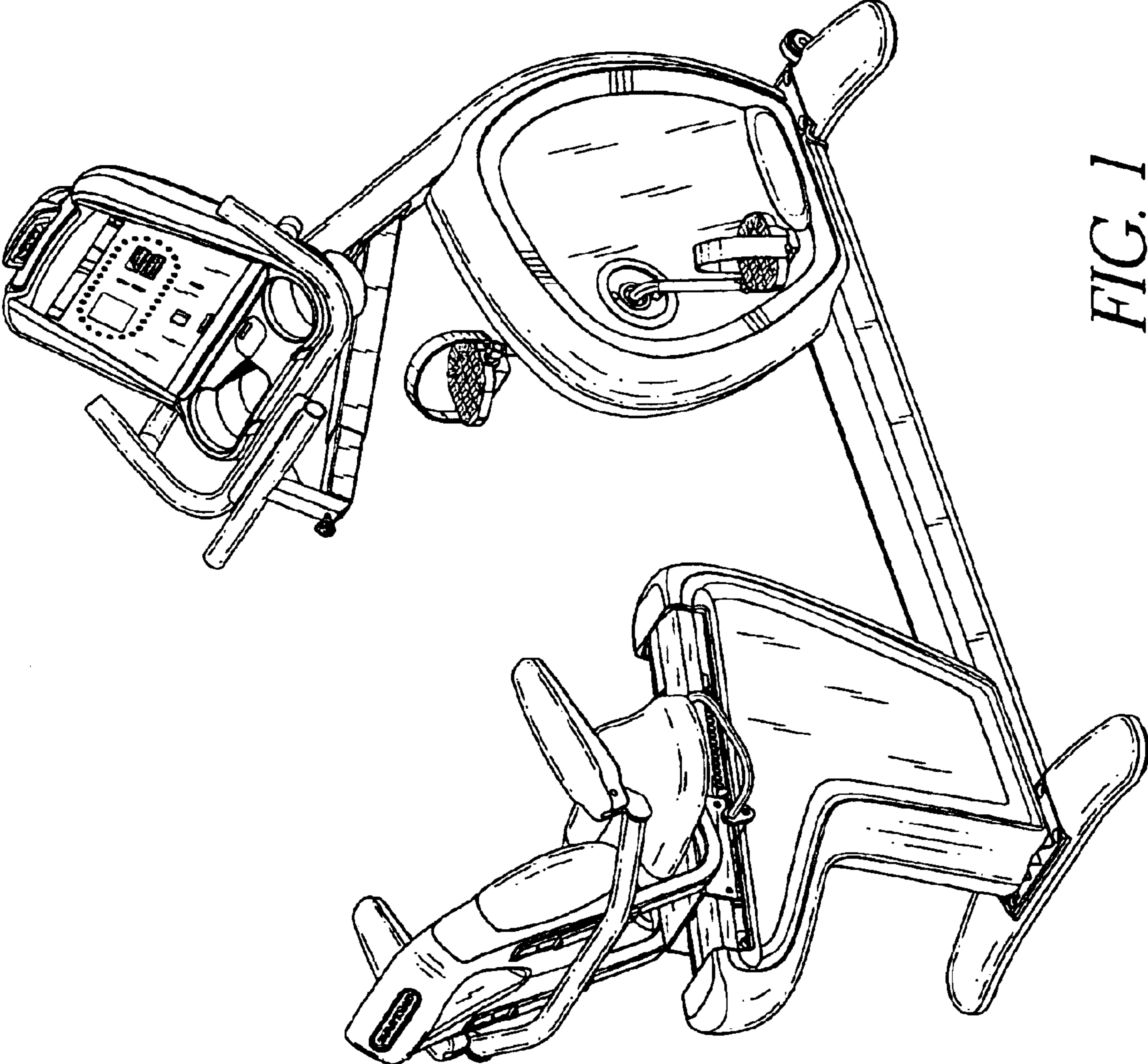

FIG. 1

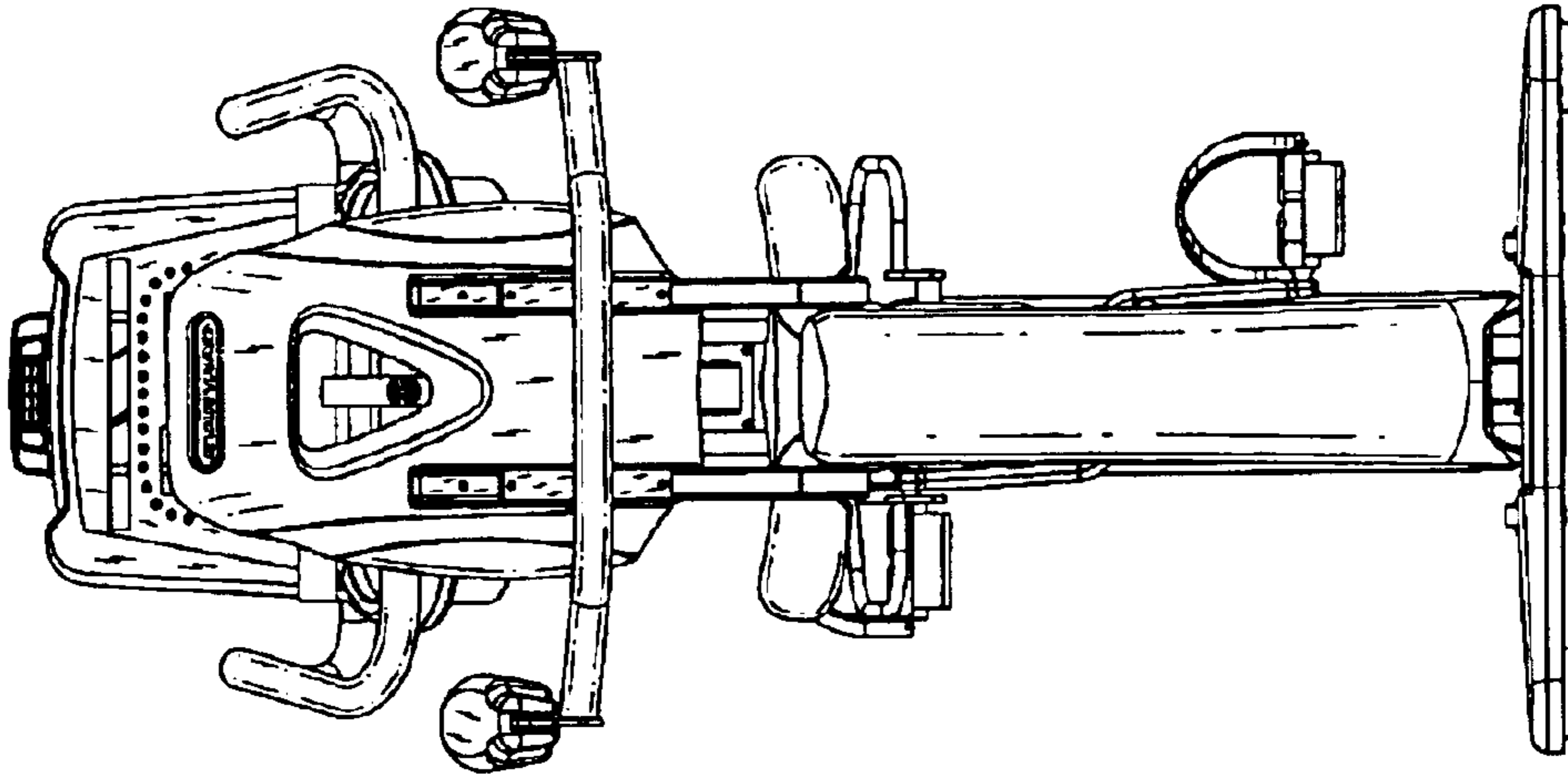

FIG. 3

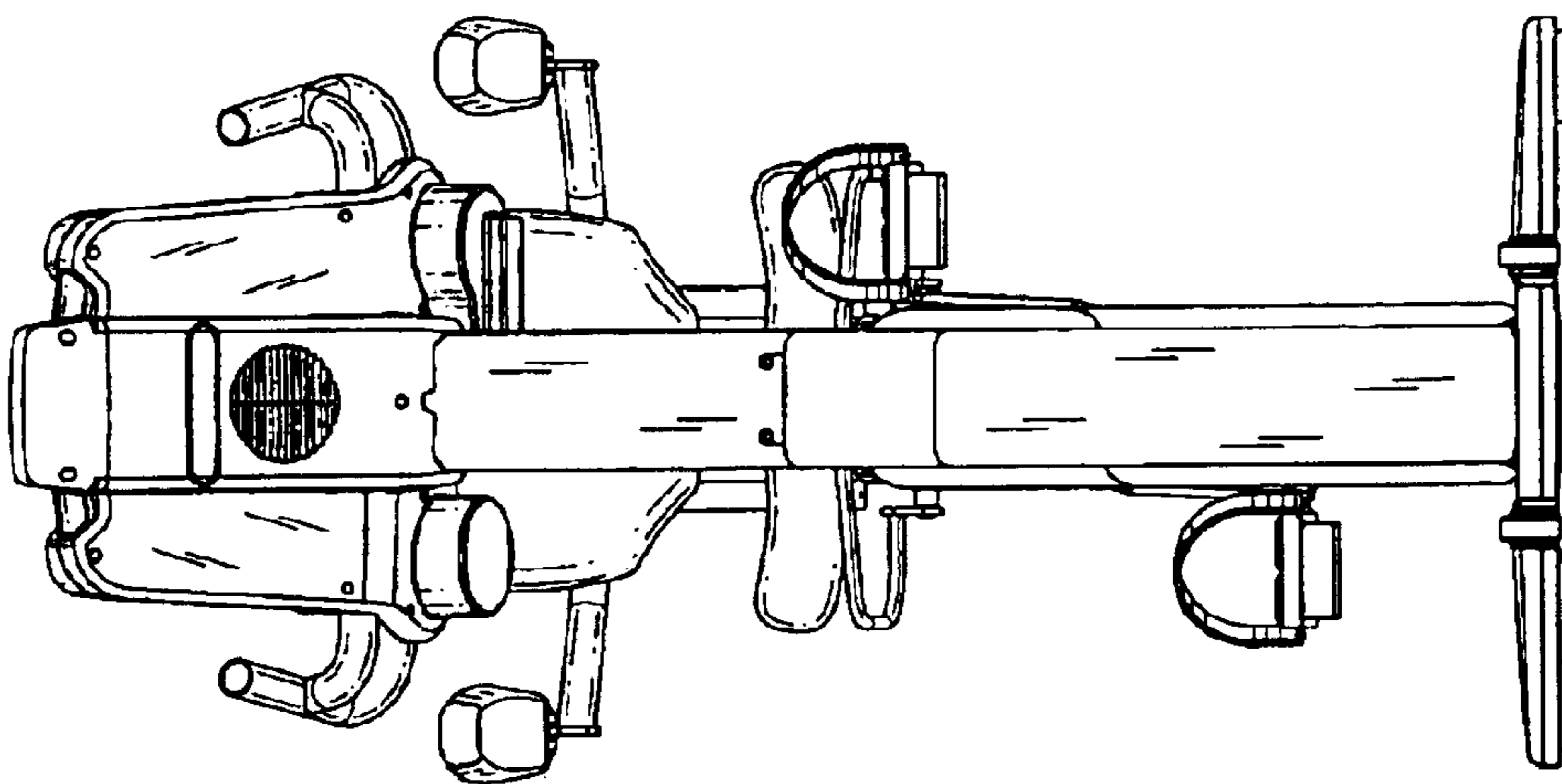

FIG. 2

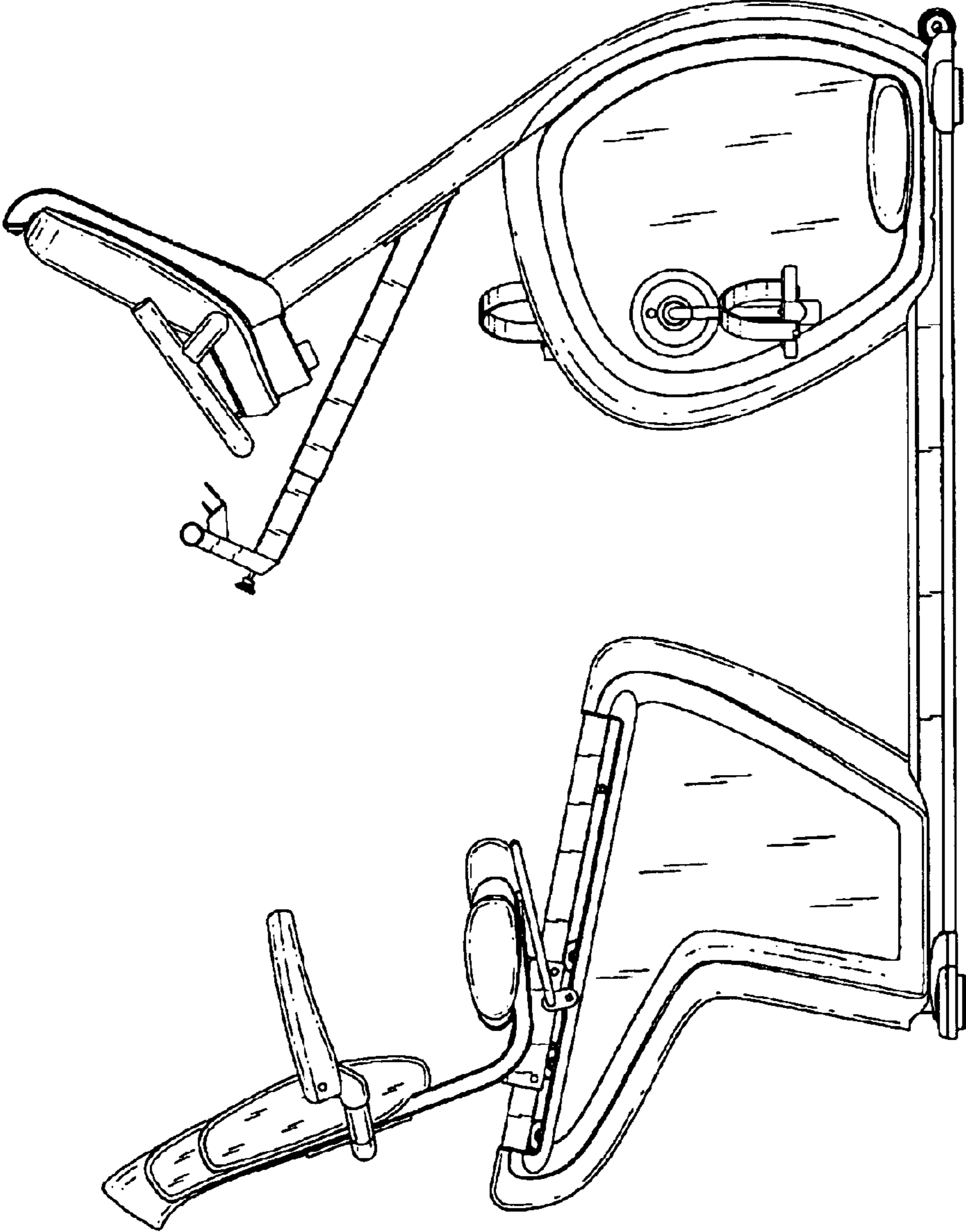

FIG. 4

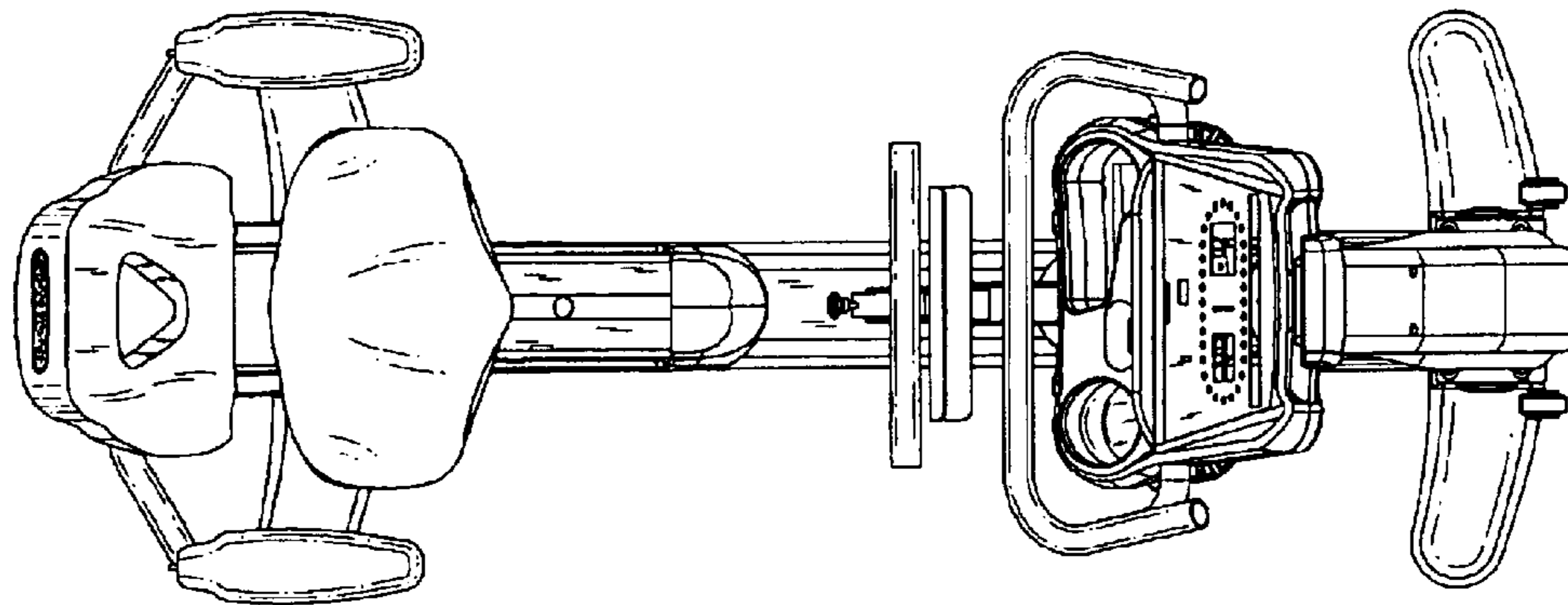

FIG. 5

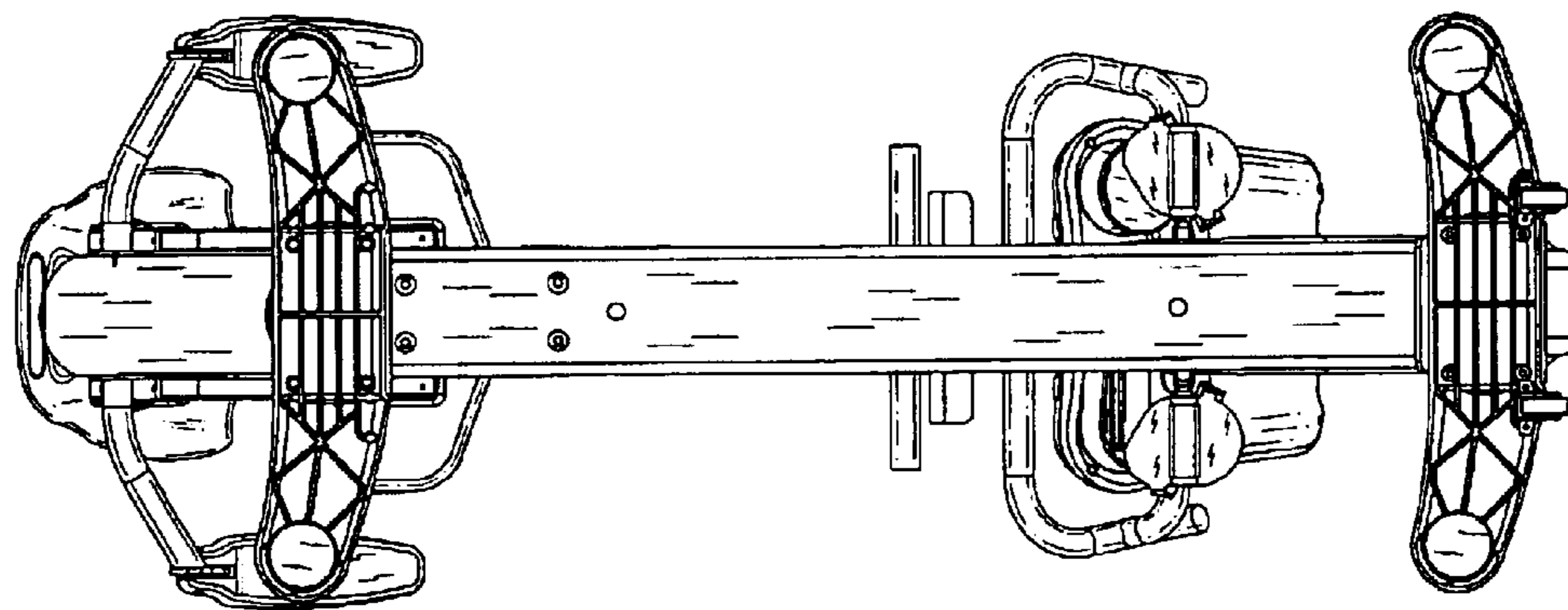

FIG. 6