

US00D515100S

(12) **United States Design Patent** (10) **Patent No.:** **US D515,100 S**
Rieves (45) **Date of Patent:** **** Feb. 14, 2006**

(54) **AIR INTAKE FOR VEHICLES**

(76) **Inventor:** **Rickey J. Rieves**, 7191 Golden Meadow Rd., Greenwood, LA (US) 71033

(**) **Term:** **14 Years**

(21) **Appl. No.:** **29/199,374**

(22) **Filed:** **Feb. 17, 2004**

(51) **LOC (8) Cl.** **15-01**

(52) **U.S. Cl.** **D15/5**

(58) **Field of Classification Search** D15/5;
296/180.1, 91; D12/173, 190, 181, 90-92;
340/468, 461, 472; 307/10.1; 180/69.24,
180/69.25, 69, 2, 69.3, 68.6

See application file for complete search history.

(56) **References Cited**

U.S. PATENT DOCUMENTS

D249,703 S	*	9/1978	Zimmerman et al.	D23/325
D316,072 S	*	4/1991	Wayne	D12/190
5,157,377 A	*	10/1992	Wayne	340/468
D353,124 S	*	12/1994	Benningfield	D12/173
D430,085 S	*	8/2000	Hoyle, Jr.	D12/173
D457,471 S	*	5/2002	Simcox	D12/173
D464,006 S	*	10/2002	Hoyle, Jr.	D12/173

OTHER PUBLICATIONS

J.C. Whitney—Everything Automotive Catalog, Scoops, Styling Accessories.

Lund Industries—“Eclipse” Hood Scoop.

* cited by examiner

Primary Examiner—Joel Sincavage

Assistant Examiner—Maurice Stevens

(74) *Attorney, Agent, or Firm*—John M. Harrison

(57) **CLAIM**

The ornamental design for an air intake for vehicles, as shown and described.

DESCRIPTION

FIG. 1 is a front perspective view of an air intake for vehicles, showing my new design. The environmental structure illustrated in broken lines forms no part of the claimed design;

FIG. 2 is a rear perspective view thereof;

FIG. 3 is a top view thereof;

FIG. 4 is a bottom view thereof;

FIG. 5 is a rear elevational view thereof;

FIG. 6 is a front elevational view thereof;

FIG. 7 is a left side elevational view thereof; and,

FIG. 8 is a right side elevational view thereof.

1 Claim, 3 Drawing Sheets

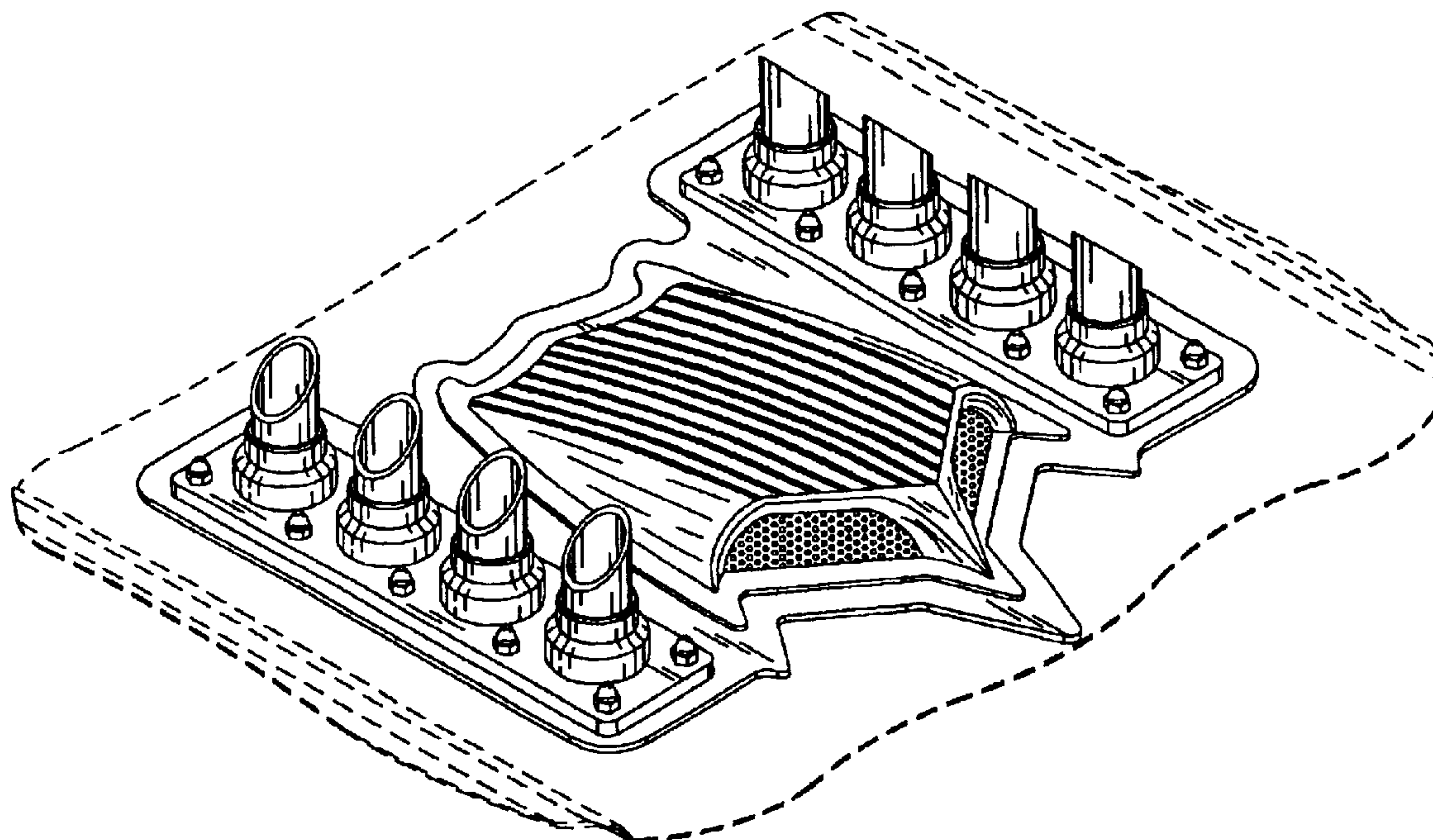

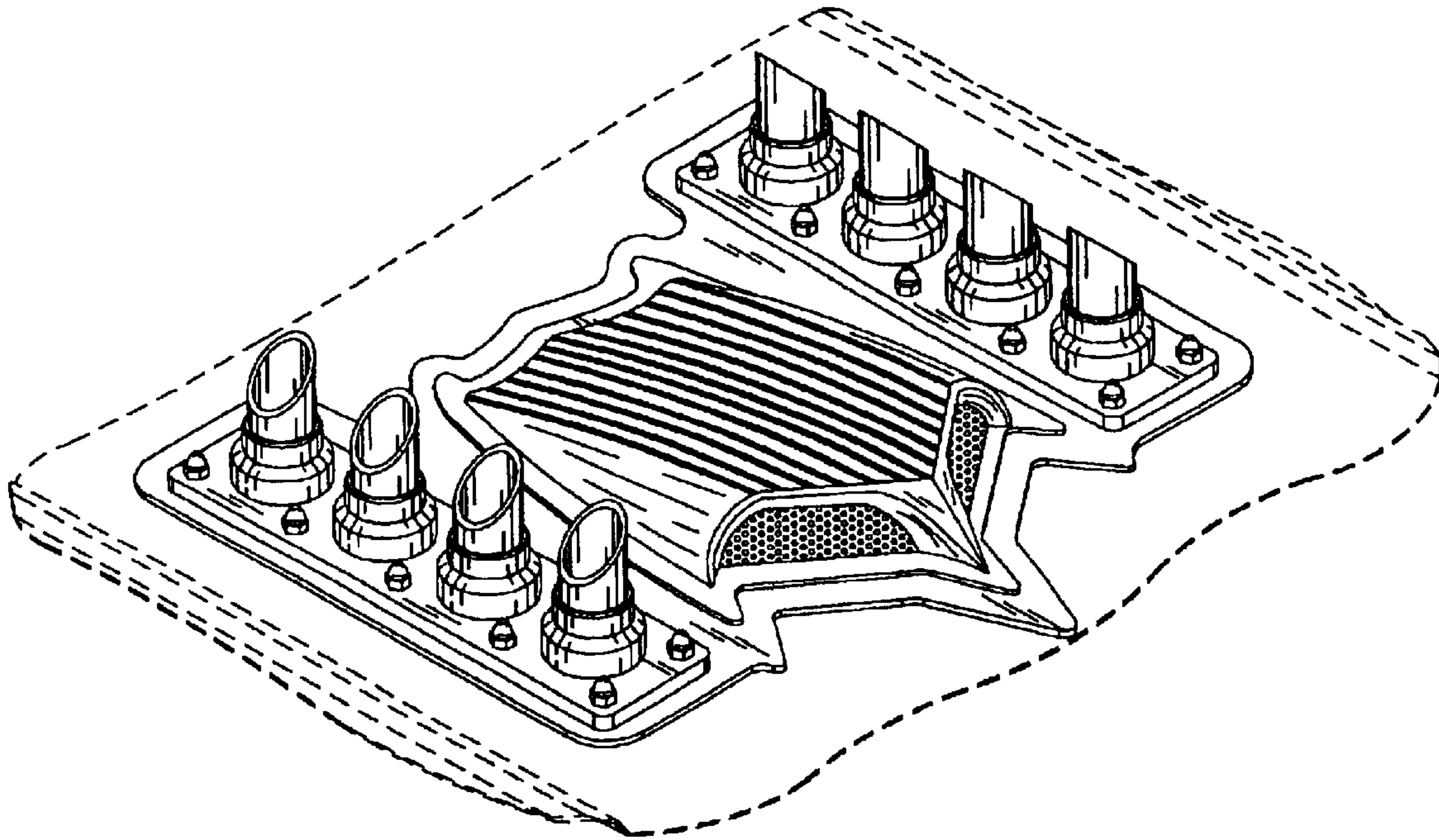

FIG. 1

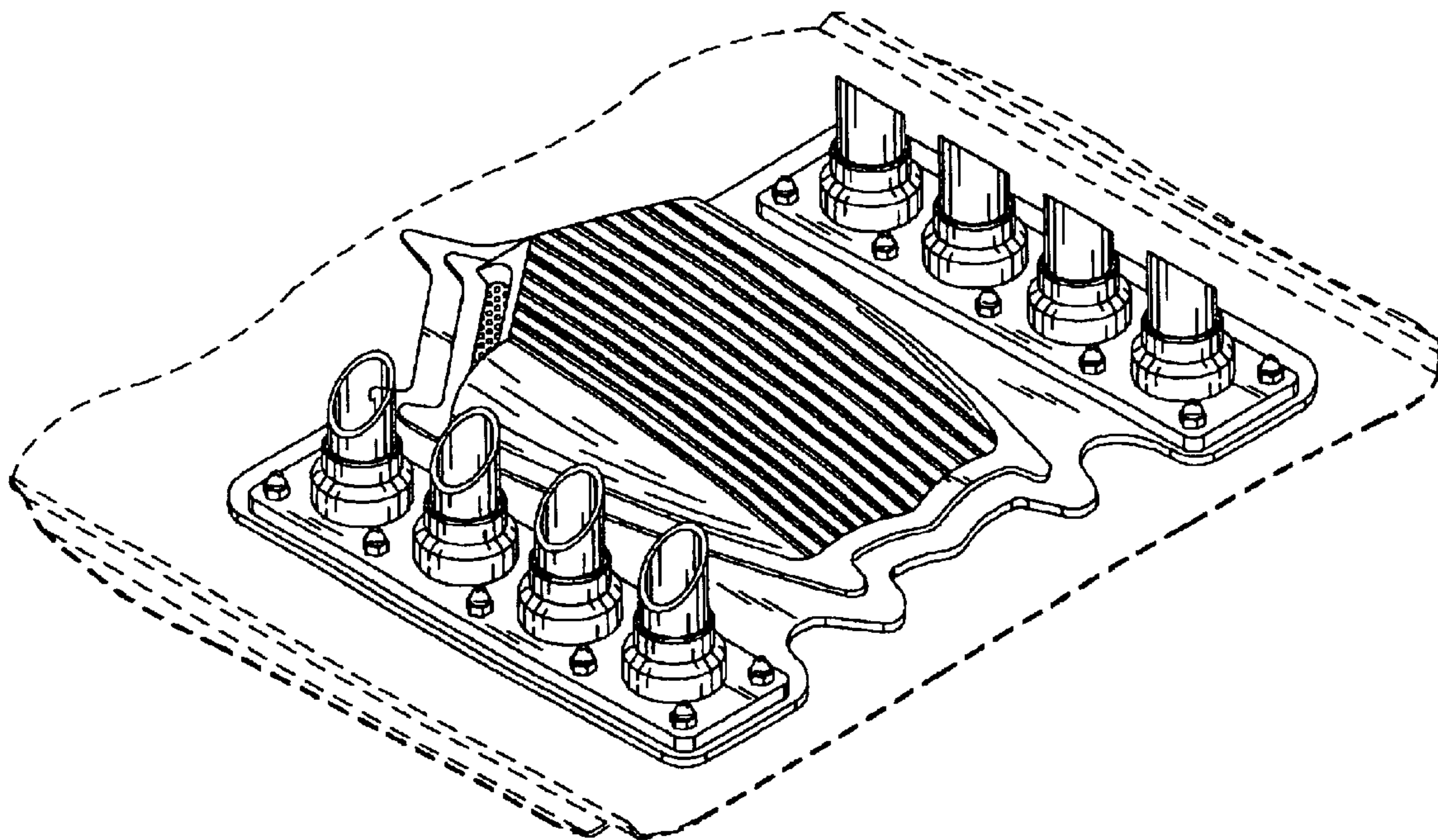

FIG. 2

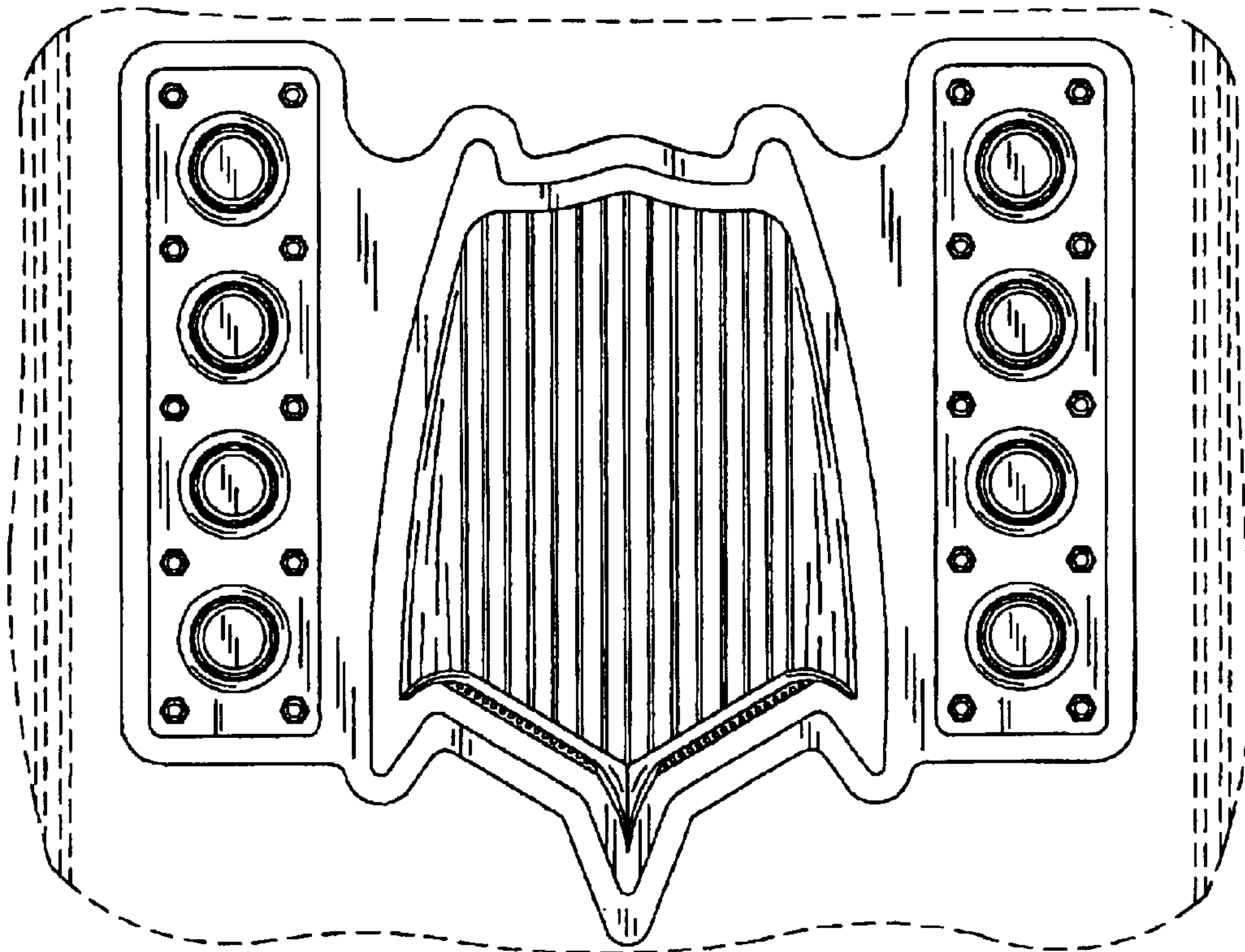

FIG. 3

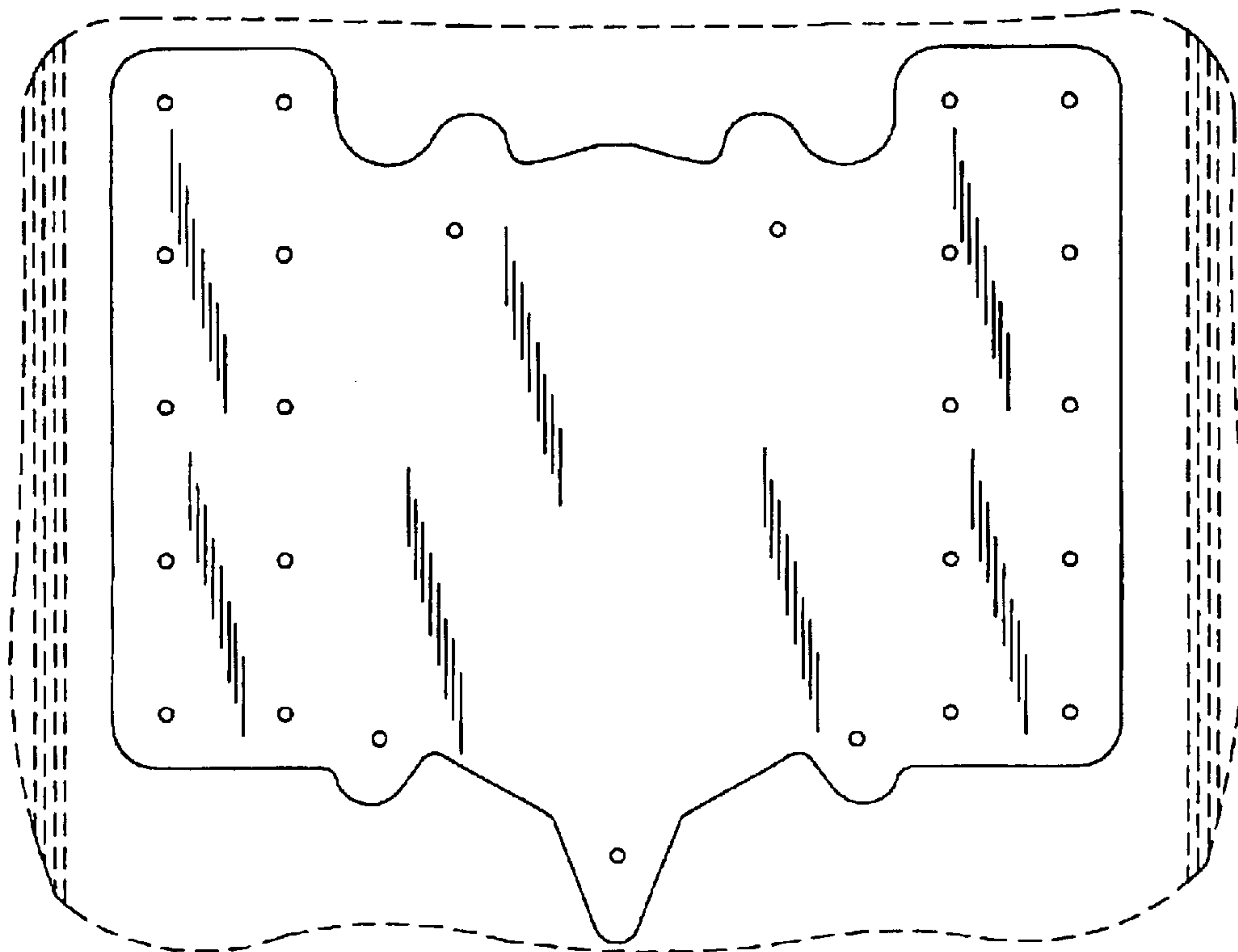

FIG. 4

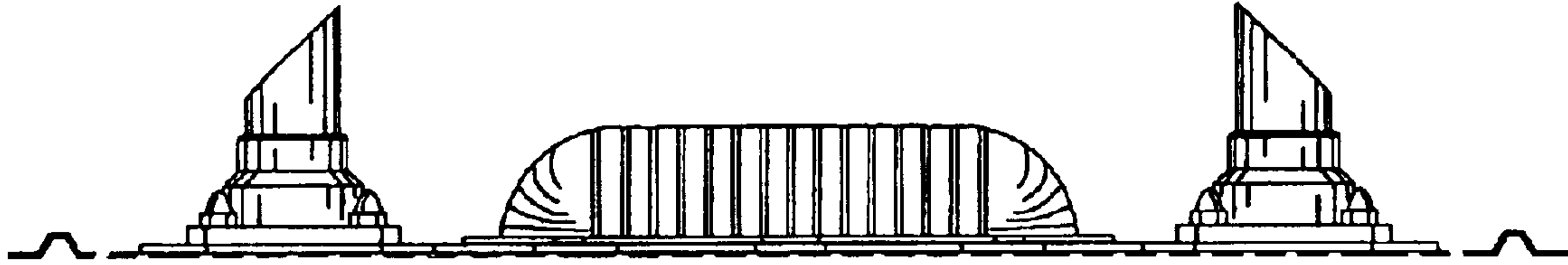

FIG. 5

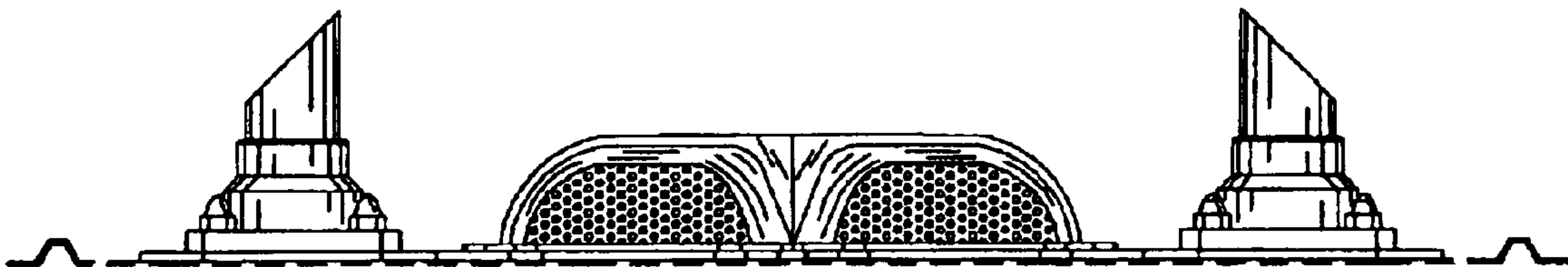

FIG. 6

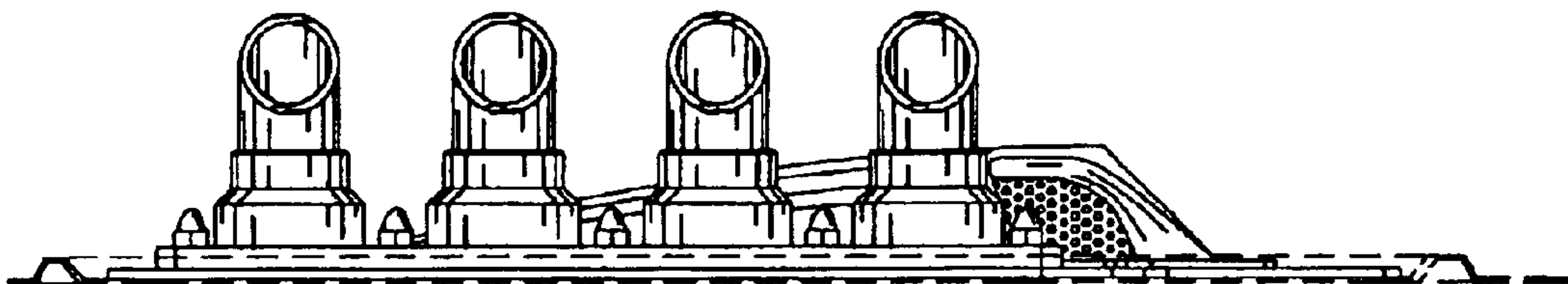

FIG. 7

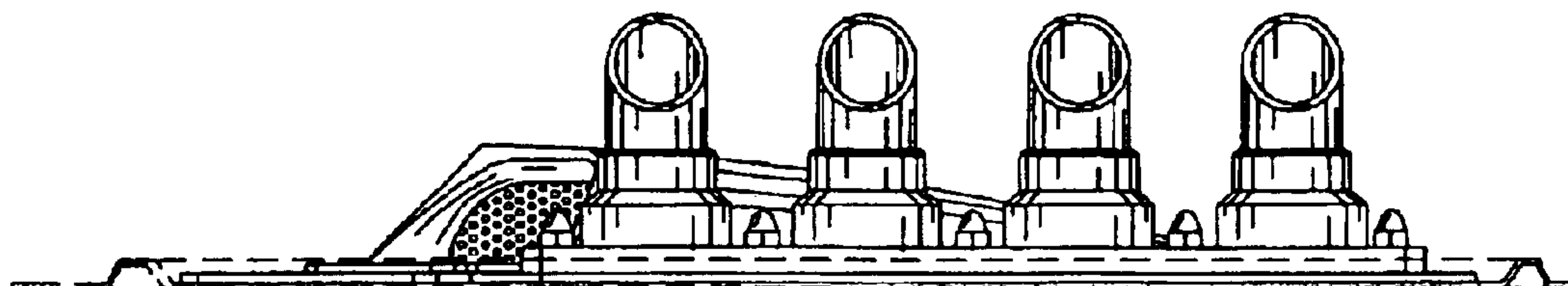

FIG. 8