



US00D515010S

(12) **United States Design Patent**
Zeiger

(10) **Patent No.:** **US D515,010 S**

(45) **Date of Patent:** **** Feb. 14, 2006**

(54) **TILT HELM FOR A BOAT STEERING WHEEL**

(76) **Inventor:** **Donald J. Zeiger**, 518 Portside Dr., Sandusky, OH (US) 44870

(**) **Term:** **14 Years**

(21) **Appl. No.:** **29/228,845**

(22) **Filed:** **Apr. 29, 2005**

Related U.S. Application Data

(62) Division of application No. 29/198,594, filed on Jan. 30, 2004.

(51) **LOC (8) Cl.** **12-06**

(52) **U.S. Cl.** **D12/317**

(58) **Field of Classification Search** D12/175, D12/176, 177, 317; 114/23, 160, 144 R; 74/493; 440/53

See application file for complete search history.

(56) **References Cited**

U.S. PATENT DOCUMENTS

- 2,267,308 A * 12/1941 Russell et al. 74/557
- D149,829 S * 6/1948 Mungen D12/177
- D158,903 S * 6/1950 Sinko D12/177
- D173,683 S * 12/1954 Sinko D12/177

- D176,297 S * 12/1955 Whitehouse D12/177
- D176,298 S * 12/1955 Whitehouse D12/177
- D185,608 S * 6/1959 Mainzinger D12/177
- 4,531,921 A * 7/1985 Teraura et al. 440/53
- 5,136,894 A * 8/1992 Carter et al. 74/493
- 6,282,977 B1 * 9/2001 Satoh et al. 74/493
- 6,588,354 B2 * 7/2003 Gai 114/144 R

* cited by examiner

Primary Examiner—Holly Baynham

Assistant Examiner—Cynthia M. Chin

(74) *Attorney, Agent, or Firm*—Zollinger & Burleson Ltd.

(57) **CLAIM**

The ornamental design for a tilt helm for a boat steering wheel, as shown and described.

DESCRIPTION

FIG. 1 is a perspective view of the tilt helm for a boat steering wheel showing my new design.

FIG. 2 is a front elevation view of FIG. 1.

FIG. 3 is a top plan view of FIG. 1.

FIG. 4 is a bottom plan view of FIG. 1.

FIG. 5 is a right side elevation view of FIG. 1; and,

FIG. 6 is a left side elevation view of FIG. 1.

The broken lines shown in the drawings form no part of the claimed invention.

1 Claim, 5 Drawing Sheets

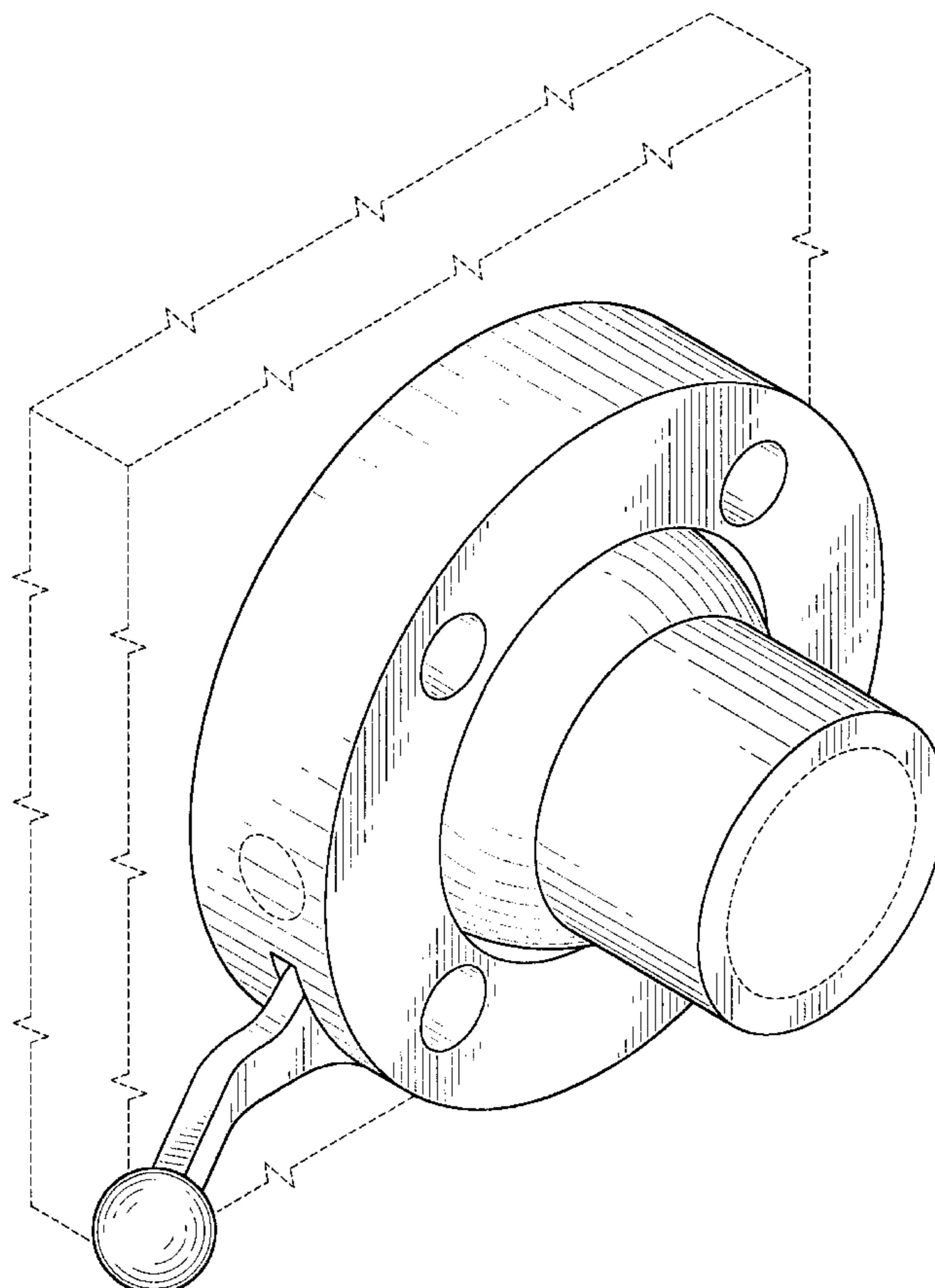

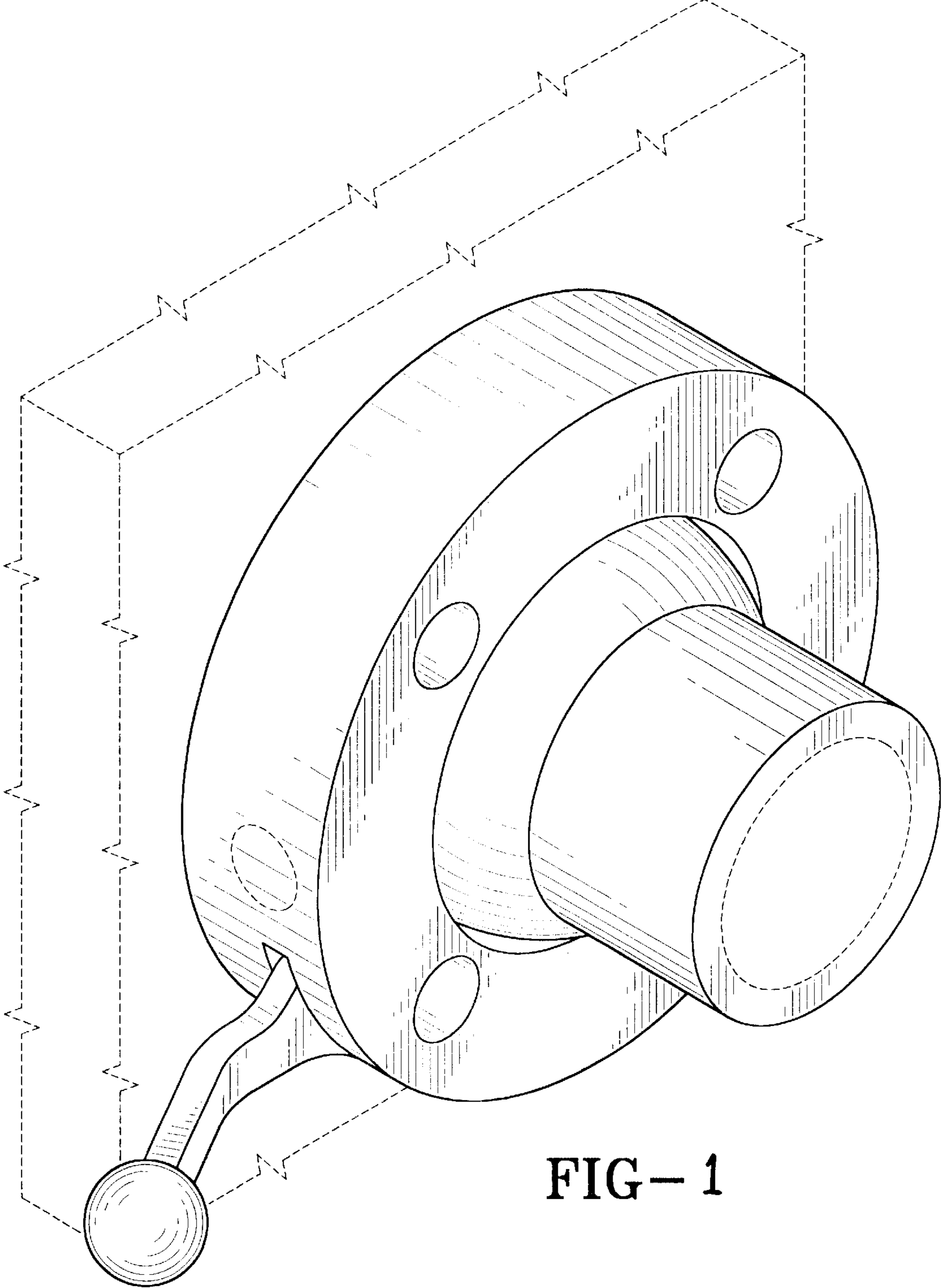

FIG-1

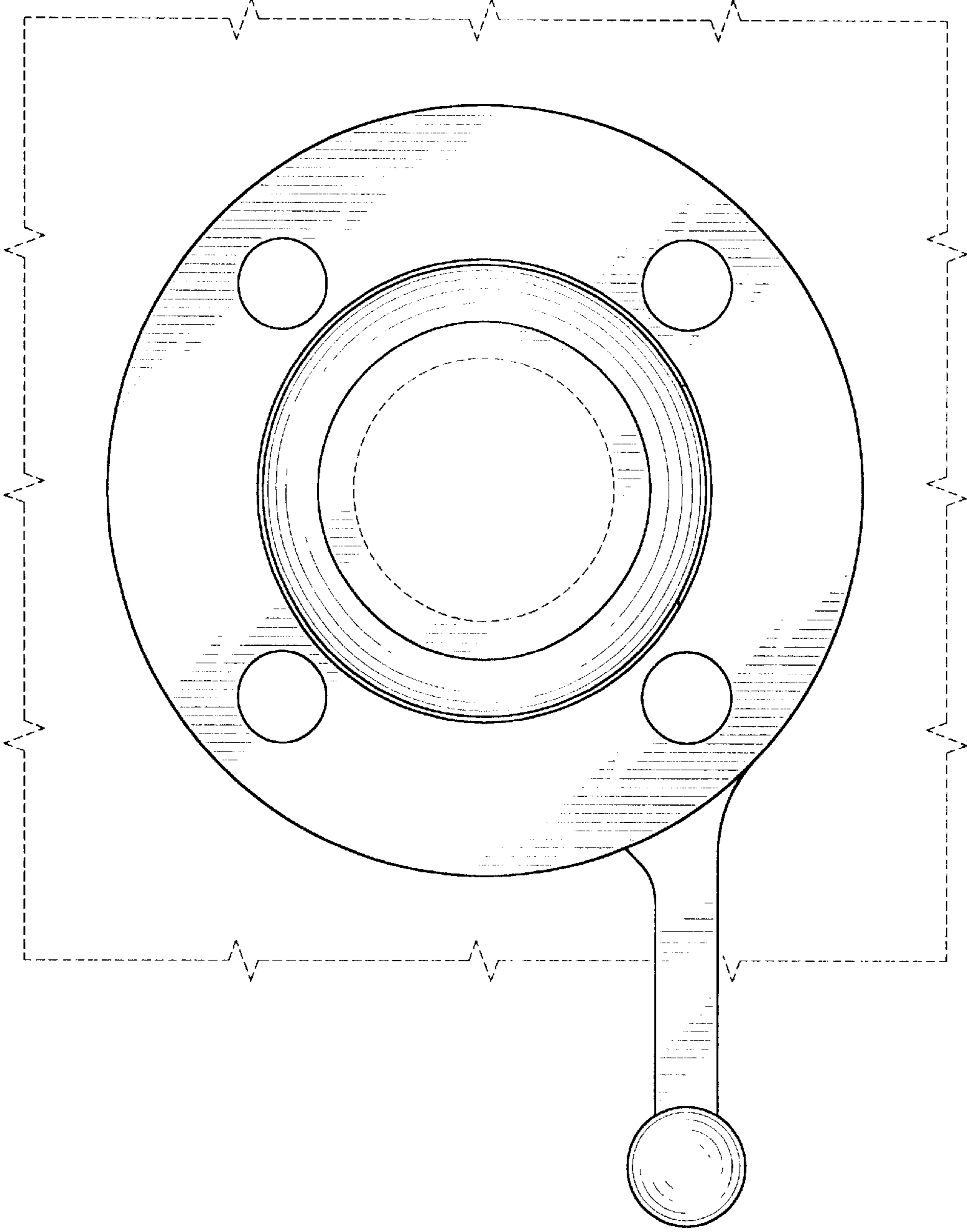

FIG-2

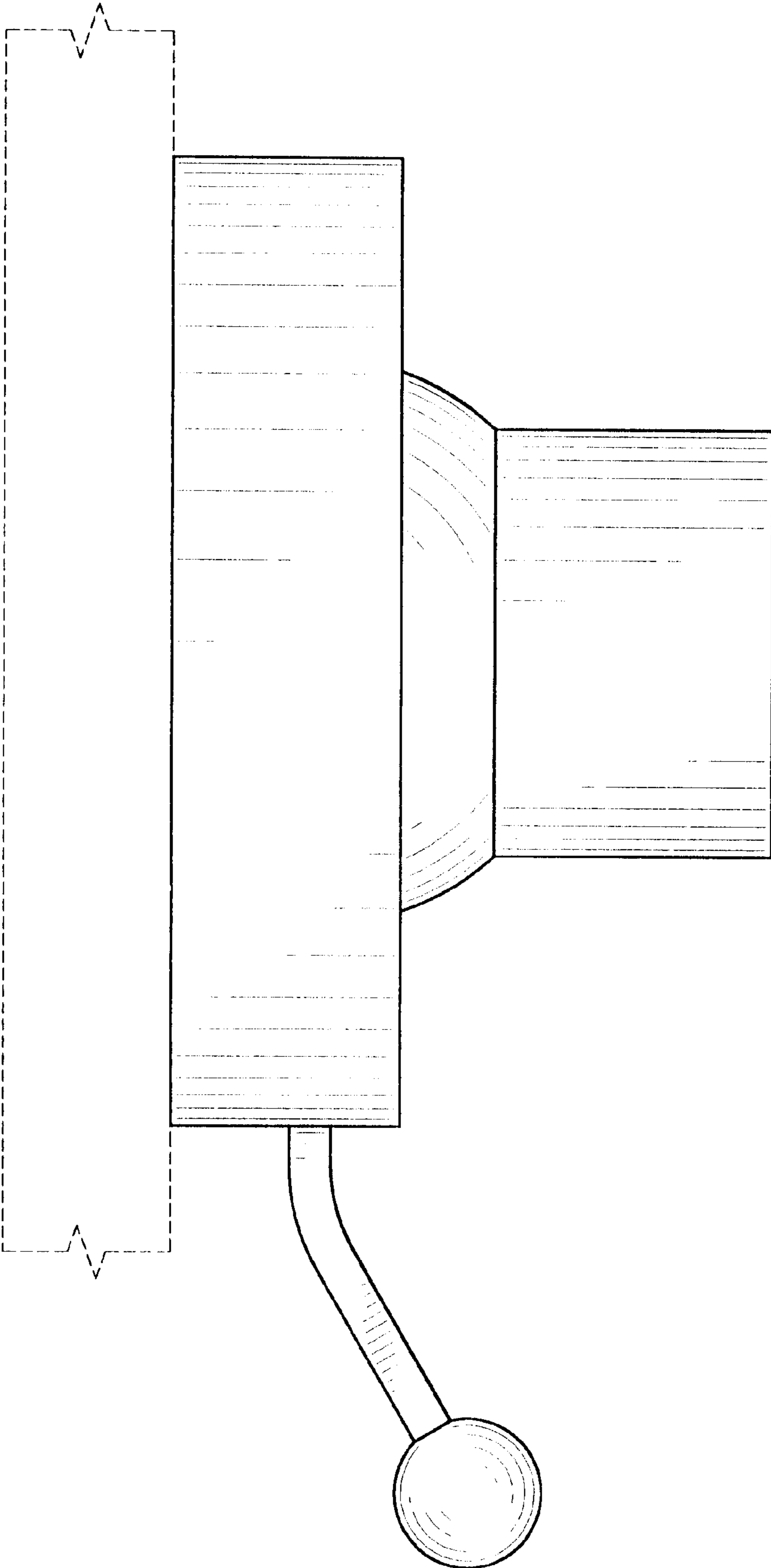

FIG-3

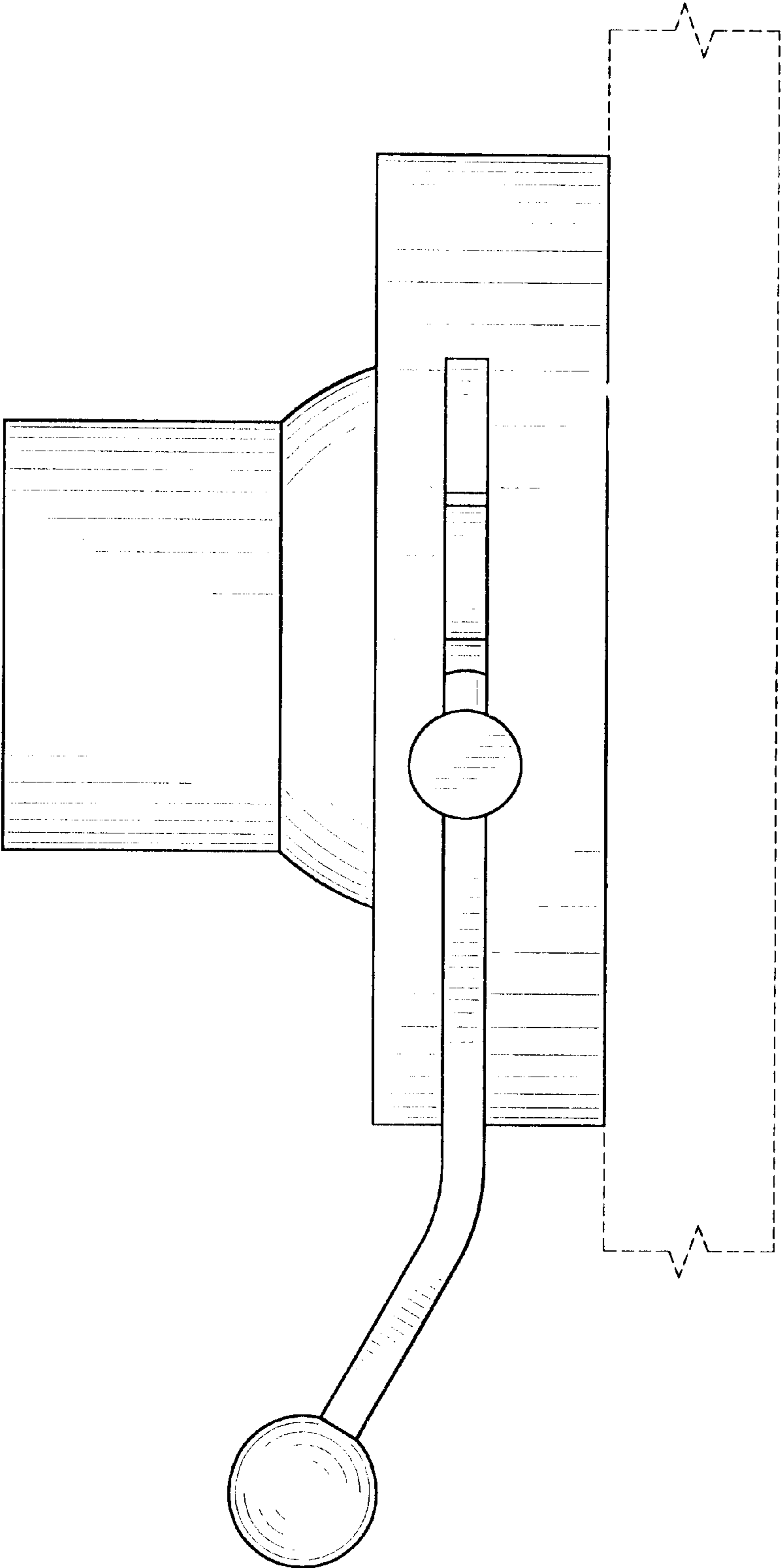

FIG-4

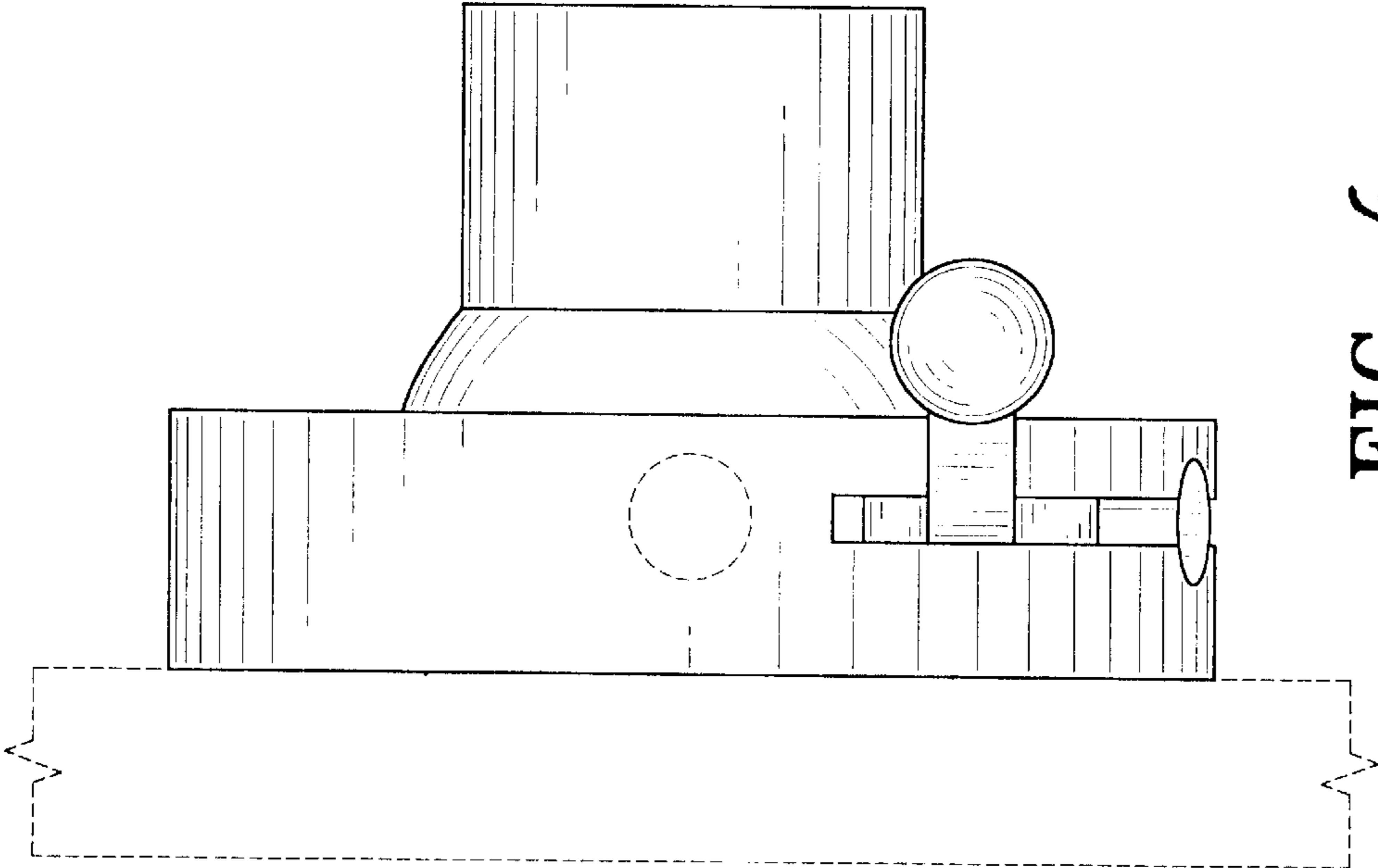

FIG-6

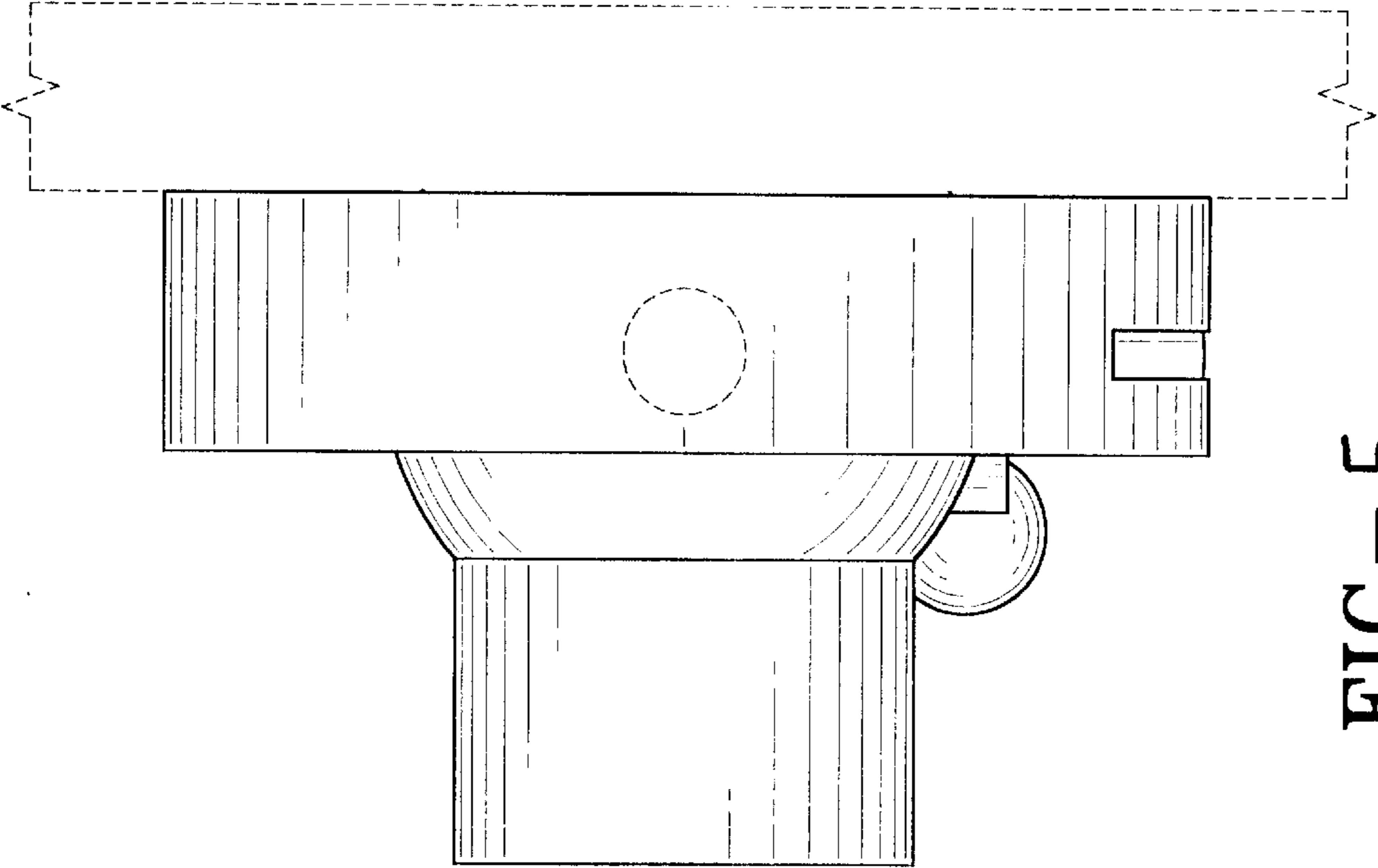

FIG-5