



US00D514716S

(12) **United States Design Patent** (10) **Patent No.:** **US D514,716 S**  
**Pfeiffer et al.** (45) **Date of Patent:** **\*\* Feb. 7, 2006**

(54) **SURFACE CONFIGURATION OF A  
TAILLIGHT FOR A VEHICLE**

(75) Inventors: **Peter Pfeiffer**, Boeblingen (DE);  
**Gorden Wagener**, Stuttgart (DE);  
**Stephen Mattin**, Sindelfingen (DE)

(73) Assignee: **DaimlerChrysler AG**, Stuttgart (DE)

(\*\*) Term: **14 Years**

(21) Appl. No.: **29/185,710**

(22) Filed: **Jul. 3, 2003**

(51) **LOC (8) Cl.** ..... **26-06**

(52) **U.S. Cl.** ..... **D26/28**

(58) **Field of Classification Search** ..... D26/28-36;  
362/459-468, 473-476, 485-487  
See application file for complete search history.

(56) **References Cited**

**U.S. PATENT DOCUMENTS**

D494,294 S \* 8/2004 Pfeiffer ..... D26/28  
D495,070 S \* 8/2004 Pfeiffer ..... D26/28  
D498,013 S \* 11/2004 Pfeiffer ..... D26/28

\* cited by examiner

*Primary Examiner*—Marcus A Jackson

(74) *Attorney, Agent, or Firm*—Crowell & Moring LLP

(57) **CLAIM**

The ornamental design for a surface configuration of a taillight for a vehicle, as shown and described.

**DESCRIPTION**

This application is related to the following co-pending application, of the inventors, filed on even date herewith: Application Ser. No. 29/185,764, entitled “Surface Configuration of a Vehicle, Toy and/or Other Replicas”.

FIG. 1 is a perspective view of a first embodiment of a surface configuration of a taillight for a vehicle according to our novel design;

FIG. 2 is a front view of the first embodiment of the surface configuration of a taillight for a vehicle according to our novel design;

FIG. 3 is a side view of the first embodiment of the surface configuration of a taillight for a vehicle according to our novel design;

FIG. 4 is a perspective view of a second embodiment of the surface configuration of a taillight for a vehicle according to our novel design;

FIG. 5 is a front view of the second embodiment of the surface configuration of a taillight for a vehicle according to our novel design; and,

FIG. 6 is a side view of the second embodiment of the surface configuration of a taillight for a vehicle according to our novel design.

The broken lines are for illustrative purposes only and form no part of the claimed design.

**1 Claim, 4 Drawing Sheets**

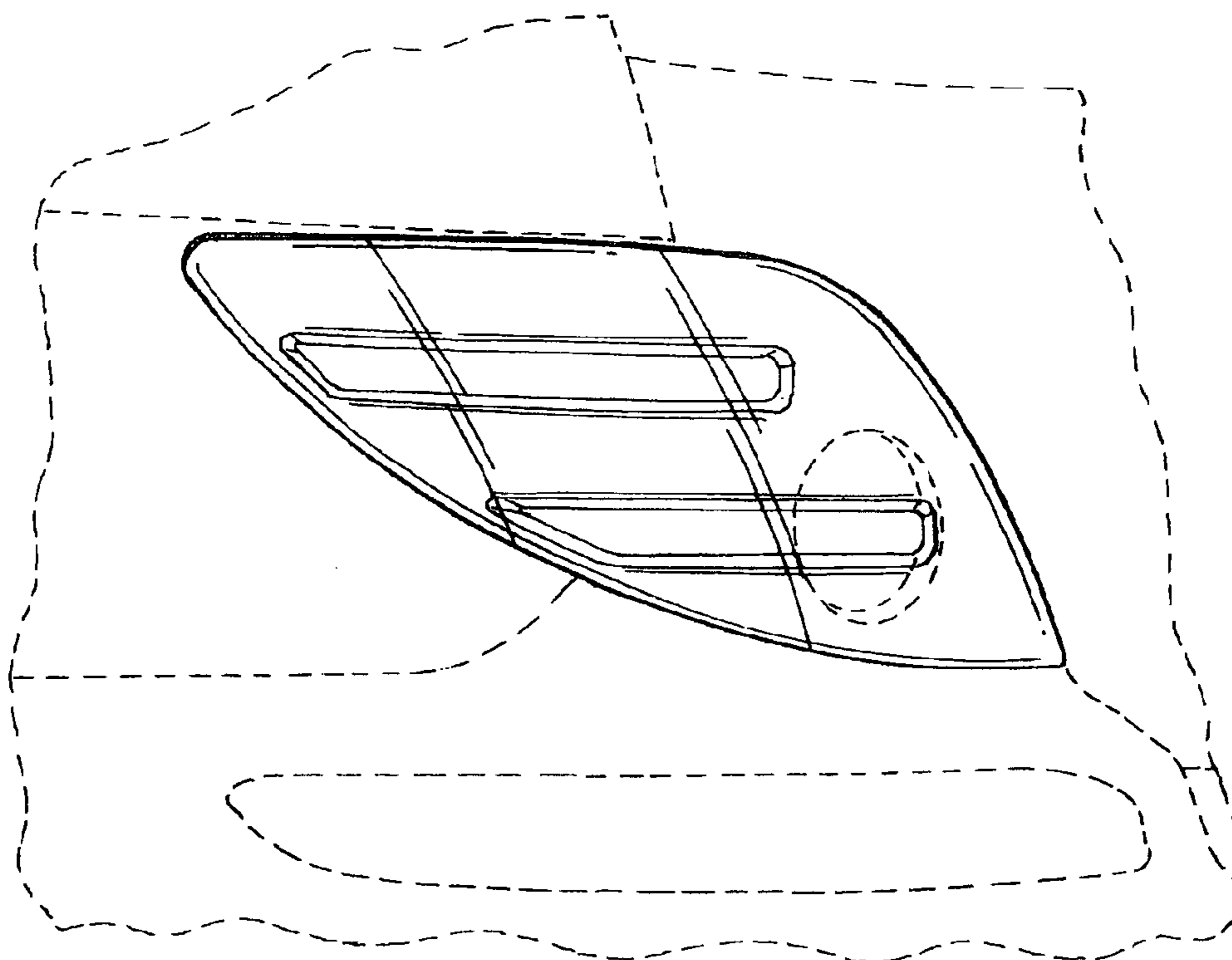

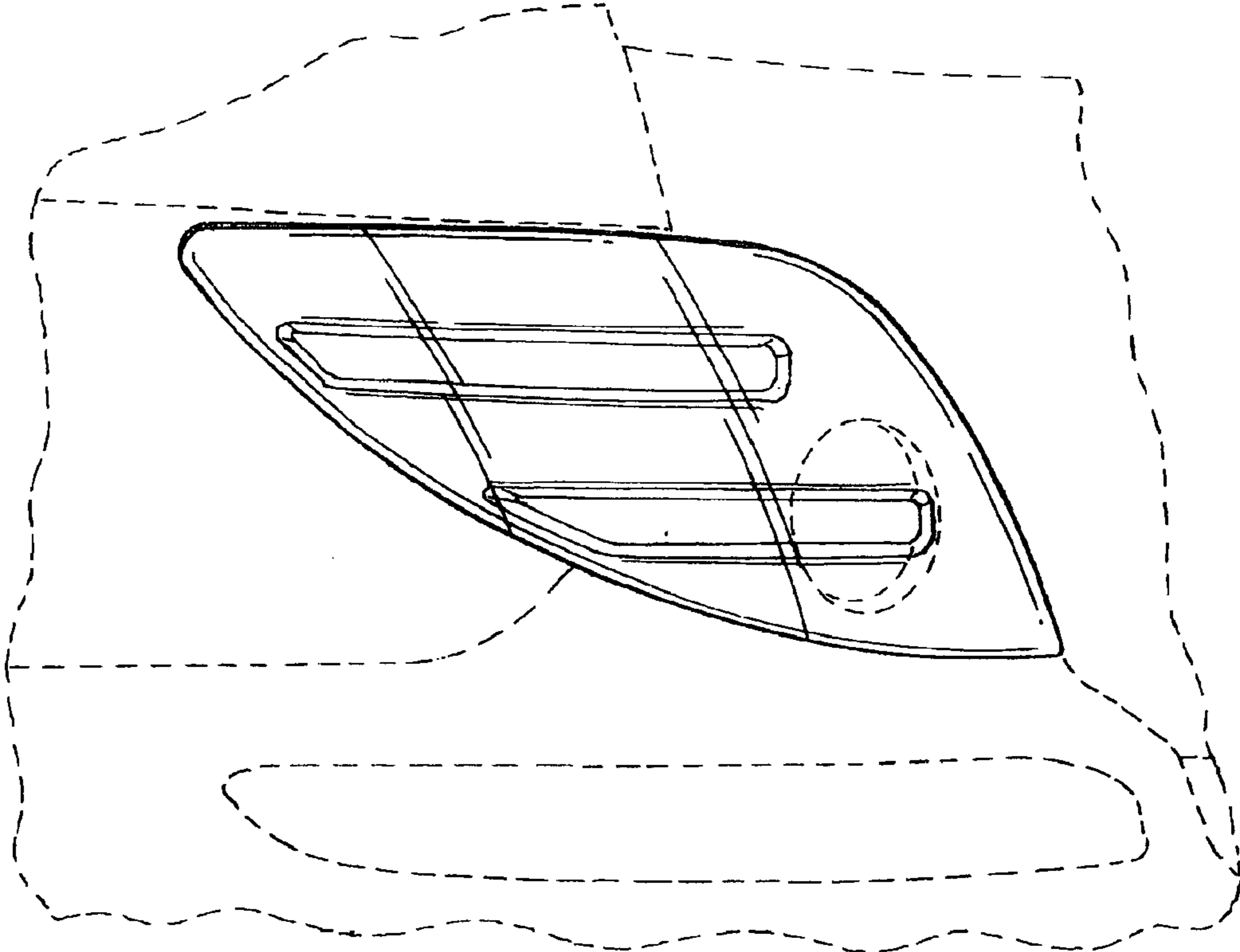

FIG. 1

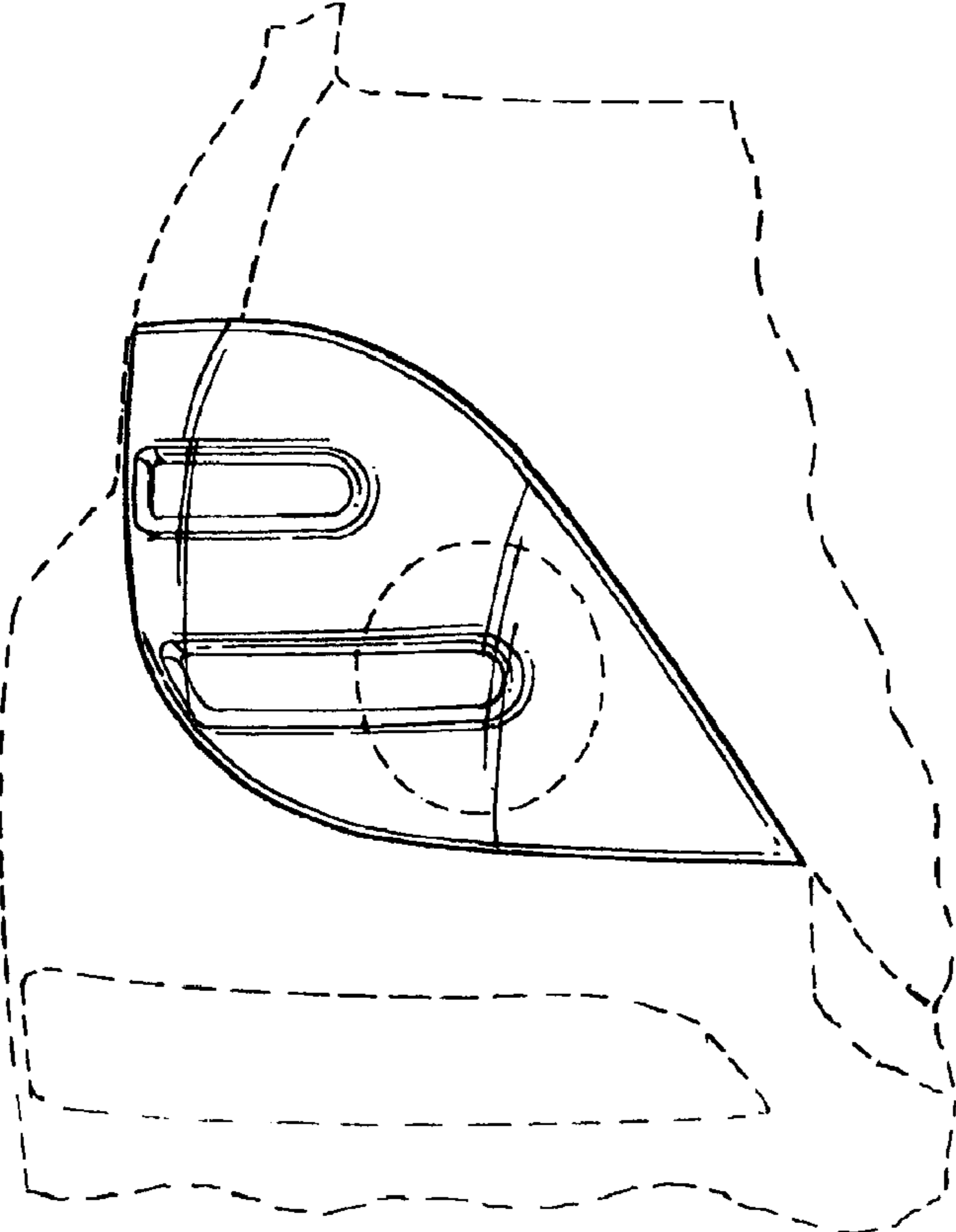

FIG. 2

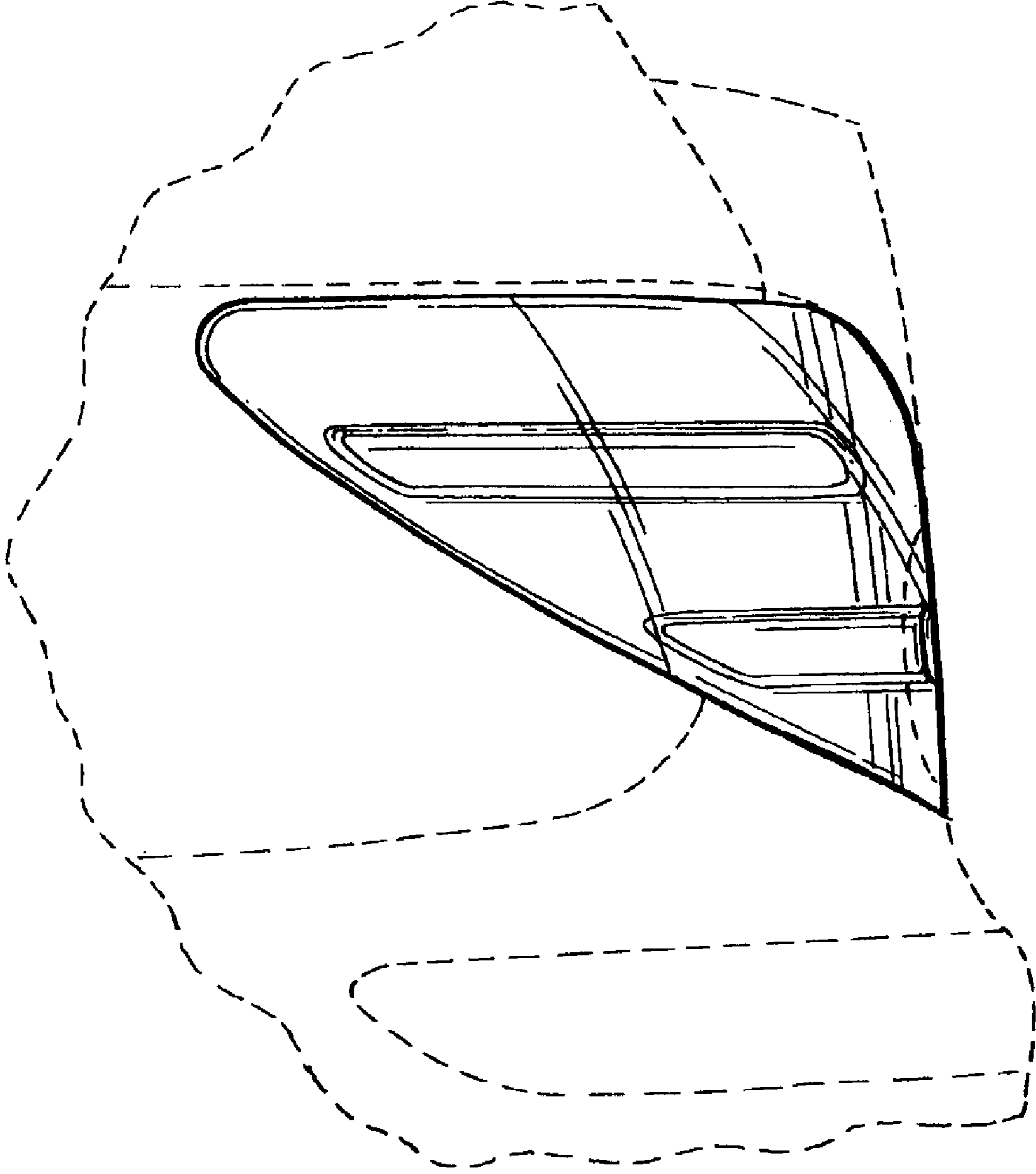

FIG. 3

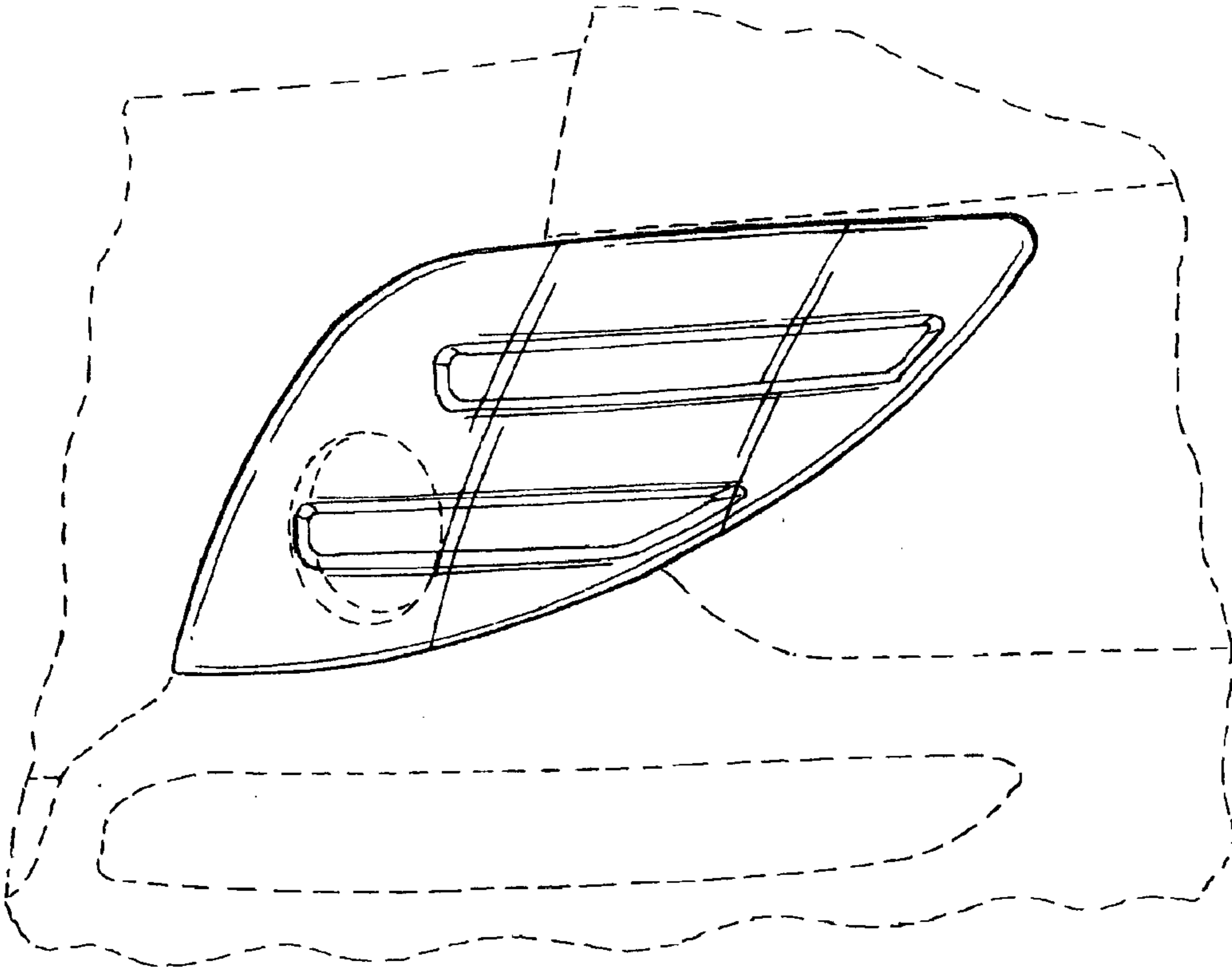

FIG. 4

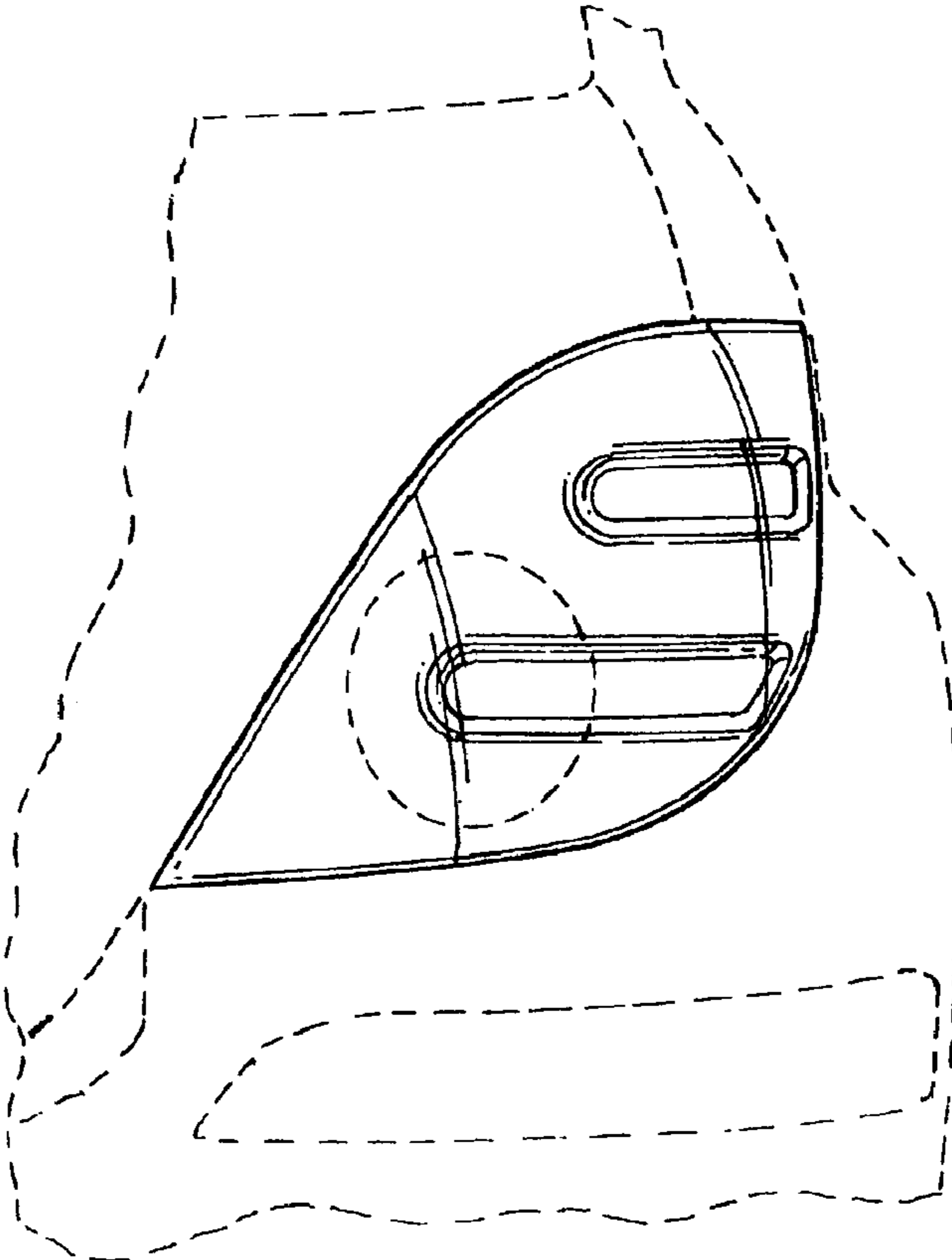

FIG. 5

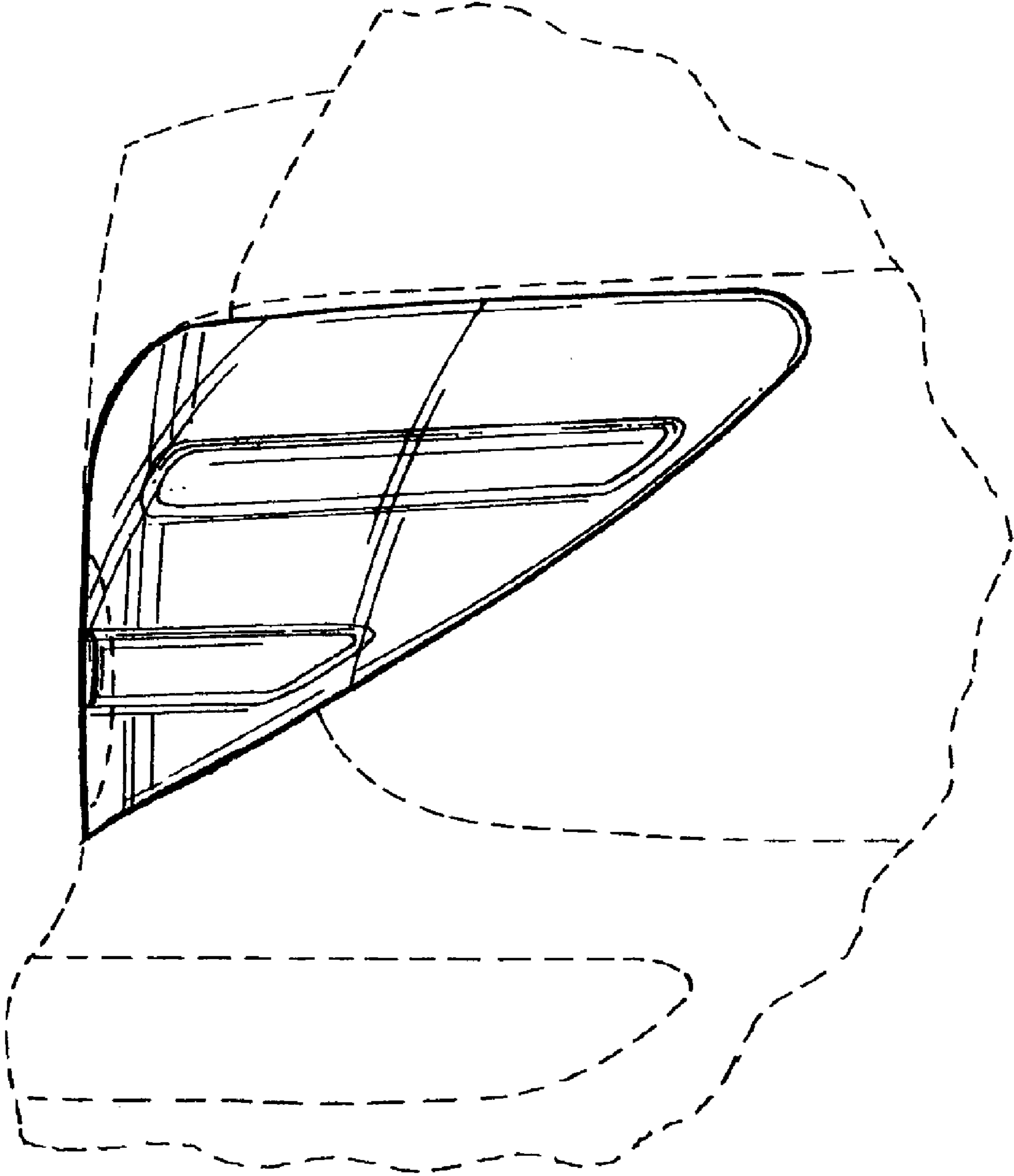

FIG. 6