



US00D514033S

(12) **United States Design Patent**
Jacklyn, II

(10) **Patent No.:** **US D514,033 S**
(45) **Date of Patent:** **** Jan. 31, 2006**

(54) **MOTORCYCLE RADIO MOUNTING BOX**

(76) **Inventor:** **Ronald J. Jacklyn, II**, 355 Horseshoe Ct., Grand Blanc, MI (US) 48439

(**) **Term:** **14 Years**

(21) **Appl. No.:** **29/209,247**

(22) **Filed:** **Jul. 13, 2004**

(51) **LOC (8) Cl.** **12-11**

(52) **U.S. Cl.** **D12/114**

(58) **Field of Classification Search** D12/110,
D12/114, 192, 415; D14/157; 180/219, 90;
280/288.4; 296/37.1, 70; 445/345; 224/413;
312/7.1; 381/86

See application file for complete search history.

(56) **References Cited**

U.S. PATENT DOCUMENTS

D242,997 S	1/1977	Dixon	D12/114
D251,120 S	2/1979	Hoese		
D257,967 S	1/1981	Hoese	D12/114
D257,971 S	1/1981	Hoese	D12/114
D266,409 S	10/1982	Hoese	D12/114
D266,410 S	10/1982	Hoese	D12/114
4,436,350 A	3/1984	Jolin	312/7.1
4,445,228 A	4/1984	Bruni	381/24
D275,382 S	9/1984	Hoese	D12/114
D345,534 S	3/1994	Abboud et al.	D12/114
D440,910 S	4/2001	Blackburn, Jr.	D12/114
D458,192 S	6/2002	Lund	D12/114

D461,760 S	8/2002	Booth	D12/409
D466,841 S	12/2002	Cohen	D12/114
D474,998 S	5/2003	Green	D12/114
6,647,121 B2	11/2003	Stanberry et al.	381/86
2002/0131606 A1	9/2002	Strawberry et al.	381/86

Primary Examiner—Alan P. Douglas

Assistant Examiner—Linda Brooks

(74) *Attorney, Agent, or Firm*—Gifford, Krass, Groh, Sprinkle, Anderson & Citkowski, P.C.

(57) **CLAIM**

I claim the ornamental design for a motorcycle radio mounting box, as shown and described.

DESCRIPTION

FIG. 1 is a front perspective view of a motorcycle radio mounting box as according to the claimed invention;

FIG. 2 is a front side view of the motorcycle radio mounting box of FIG. 1;

FIG. 3 is a back side view of the motorcycle radio mounting box of FIG. 1;

FIG. 4 is a top side view of the motorcycle radio mounting box of FIG. 1; and,

FIG. 5 is a left side view of the motorcycle radio mounting box of FIG. 1.

The broken lines immediately adjacent the shaded areas represent the boundaries of the claimed design while all other broken lines are directed to environment and are for illustrative purposes only; the broken lines form no part of the claimed design.

1 Claim, 2 Drawing Sheets

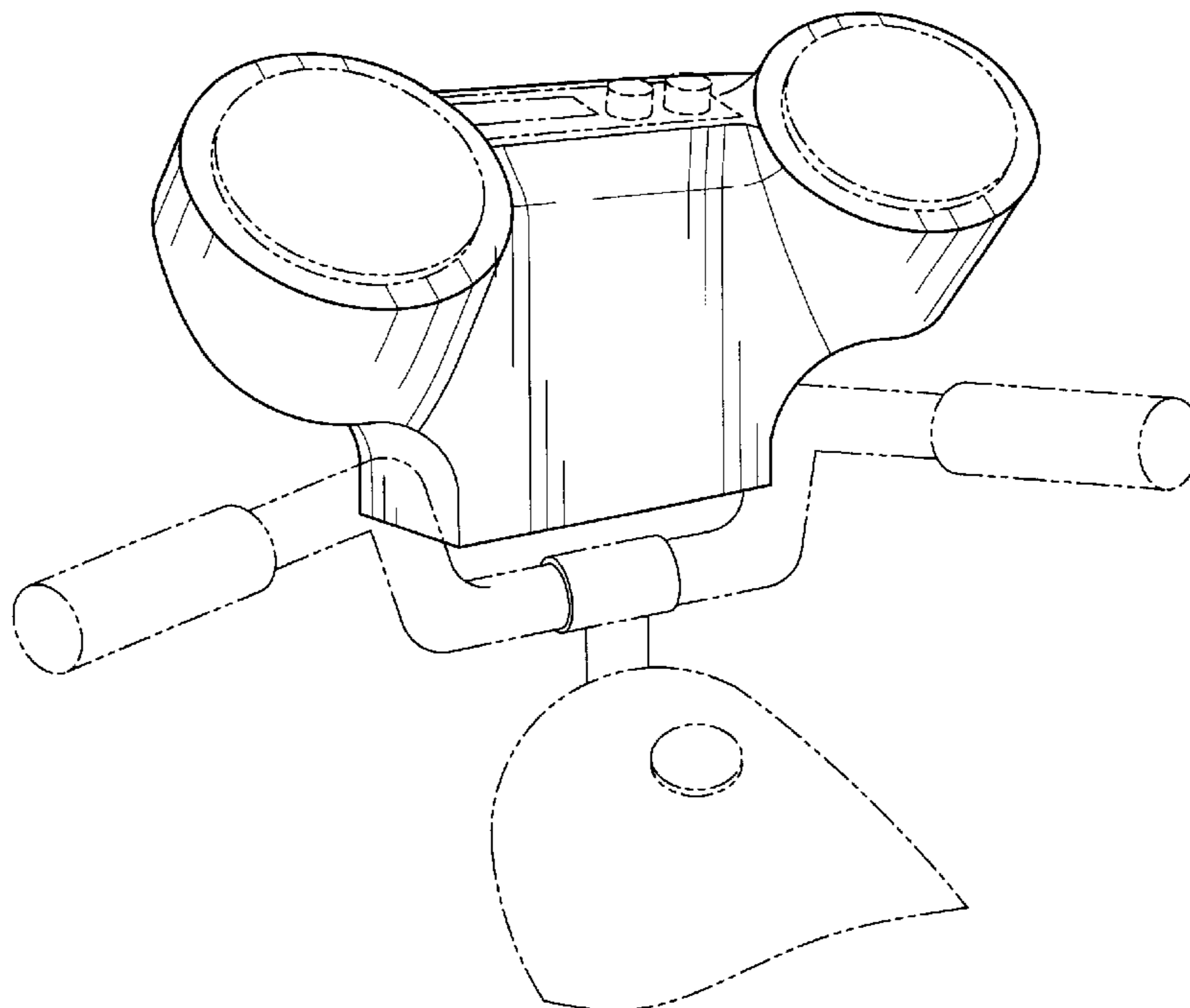

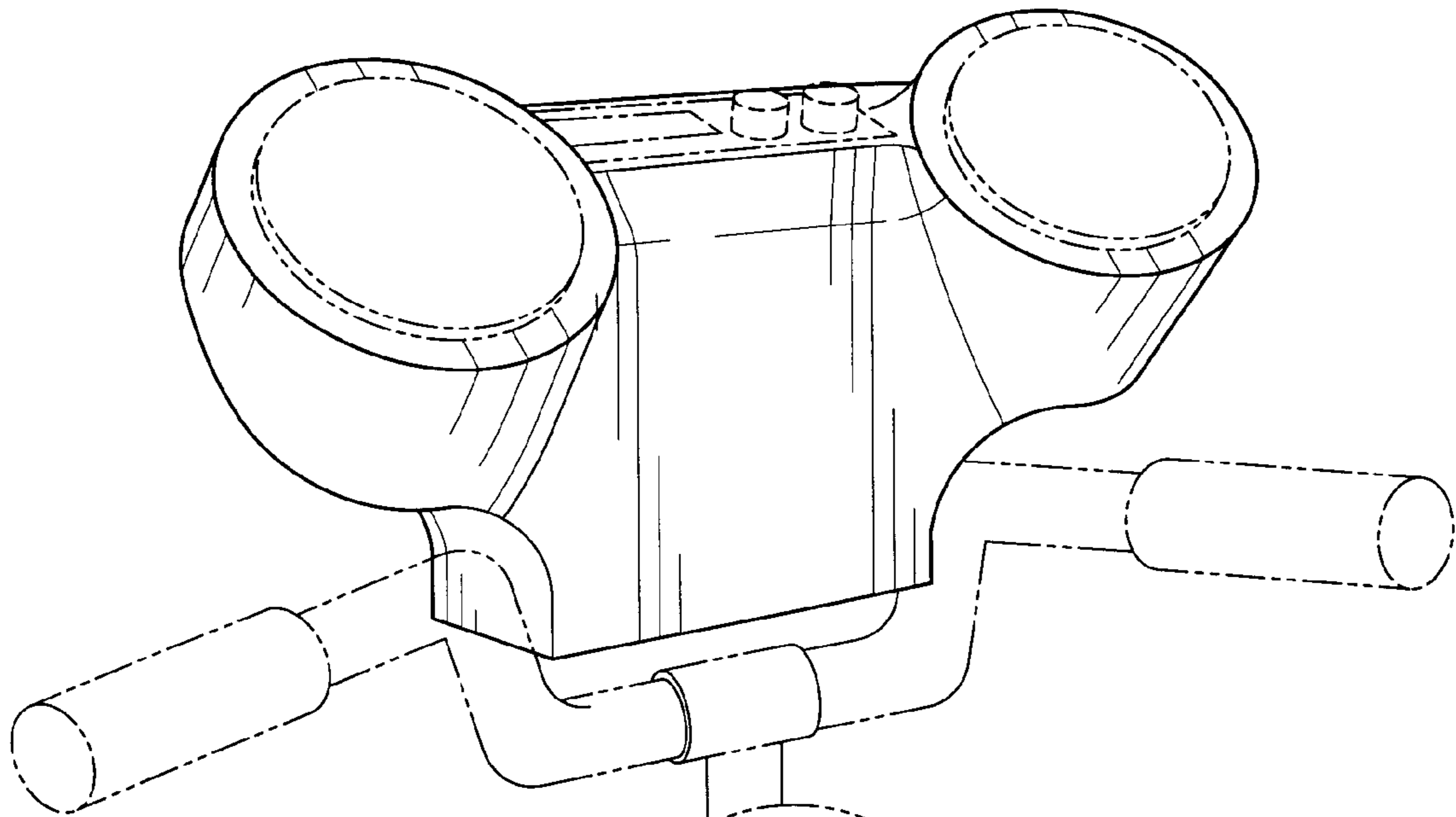

Fig-1

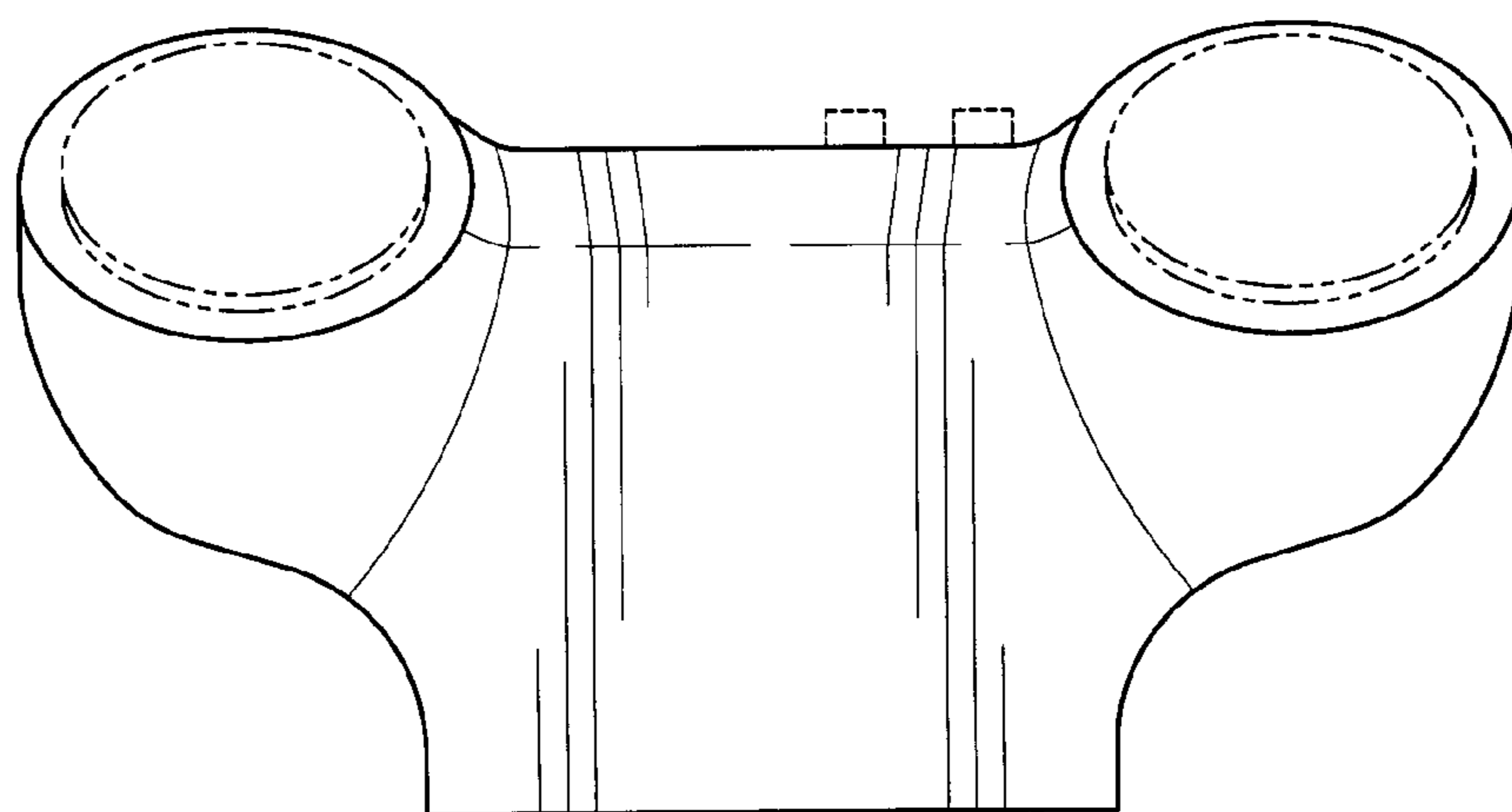
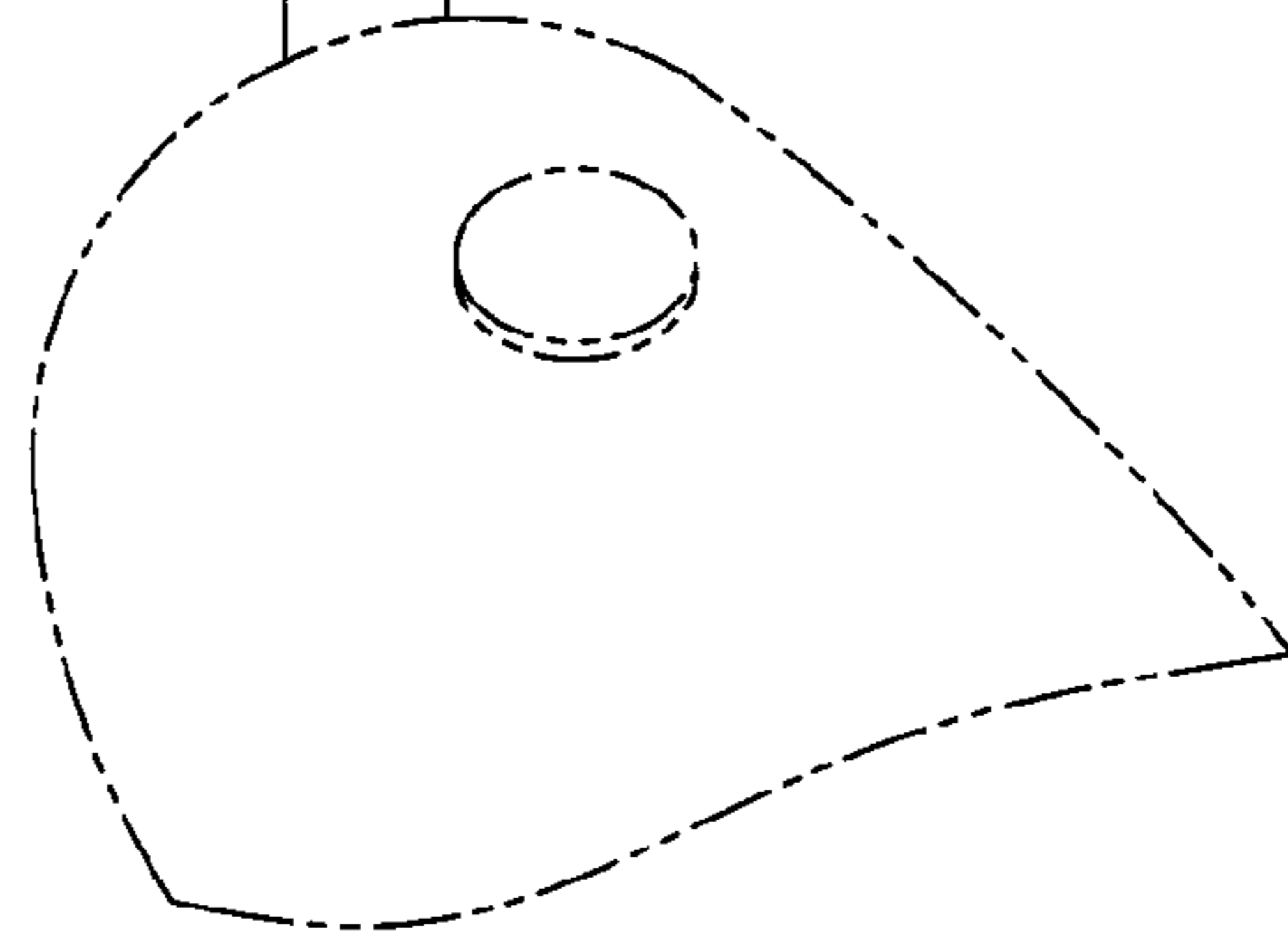

Fig-2

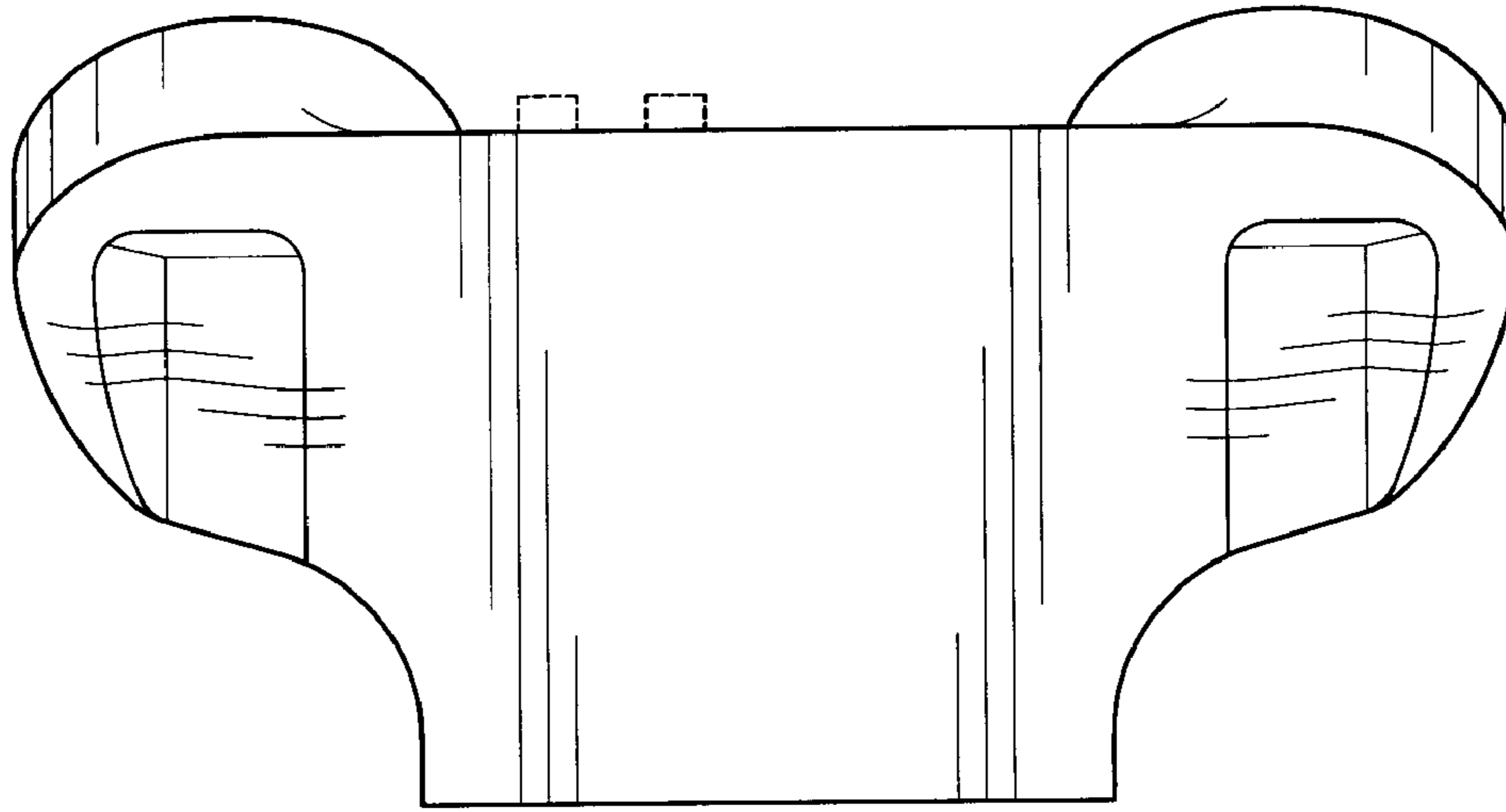

Fig-3

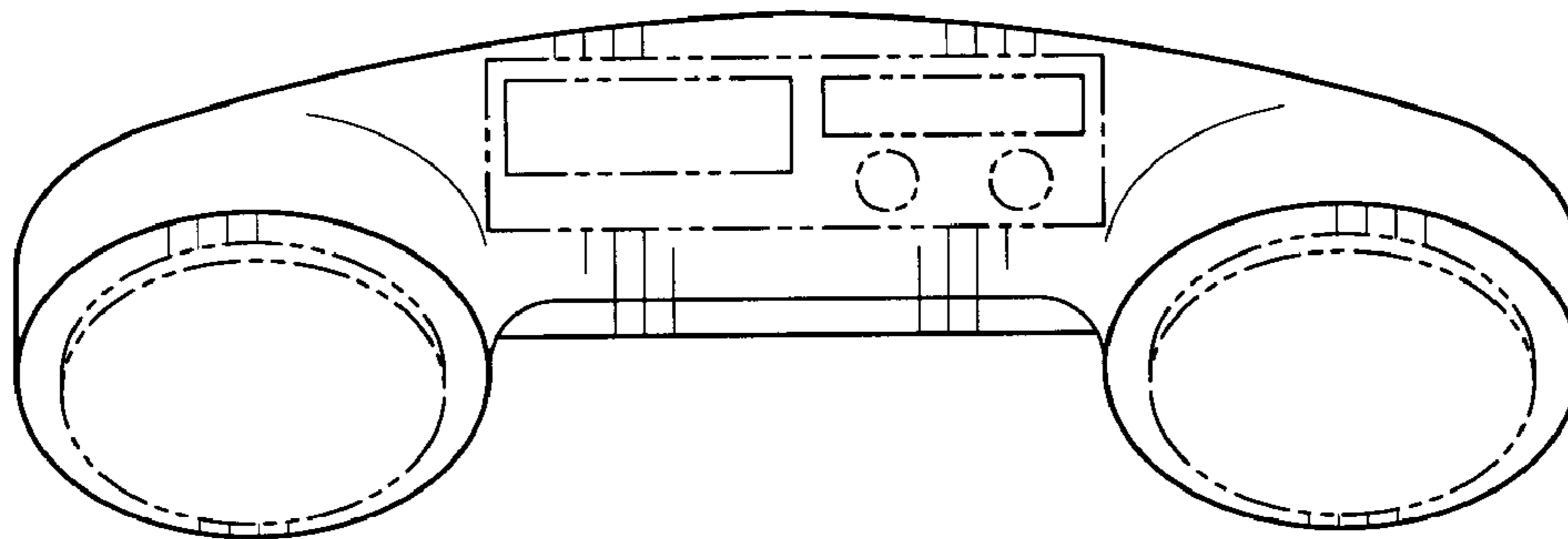

Fig-4

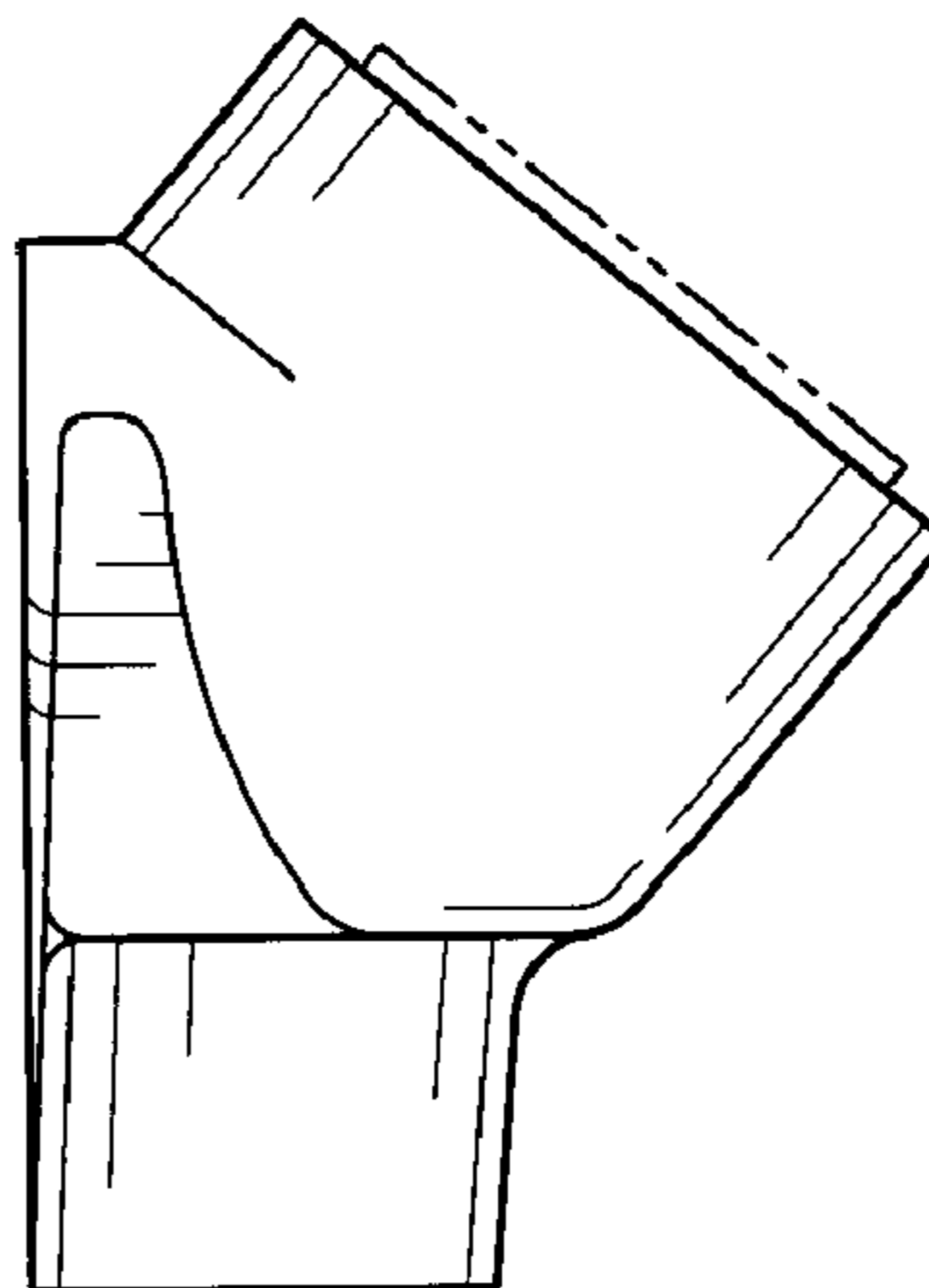

Fig-5