



US00D513793S

(12) **United States Design Patent** (10) **Patent No.:** **US D513,793 S**
Copeland et al. (45) **Date of Patent:** **** Jan. 24, 2006**

(54) **PIPE GLAND**

4,309,050 A 1/1982 Legris
 4,407,893 A 10/1983 Malizio
 4,413,733 A 11/1983 Dunn et al.
 4,437,242 A 3/1984 Battle

(75) Inventors: **Daniel A. Copeland**, Bessemer, AL
 (US); **William H. Owen**, Fultondale,
 AL (US)

(Continued)

(73) Assignee: **United States Pipe and Foundry
 Company**, Birmingham, AL (US)

FOREIGN PATENT DOCUMENTS

EP 0 334 380 A2 9/1989

(**) Term: **14 Years**

OTHER PUBLICATIONS

(21) Appl. No.: **29/207,349**

U.S. Pipe and Foundry Company; Ductile Iron Mechanical
 Joint Fittings for Water or Other Liquids; Brochure 007;
 Dated Oct., 2002; pp. 1-3.

(22) Filed: **Jun. 11, 2004**

(Continued)

(51) **LOC (8) Cl.** **23-01**

(52) **U.S. Cl.** **D23/262**

(58) **Field of Classification Search** D23/262,
 D23/265, 259; 285/356, 303, 337
 See application file for complete search history.

Primary Examiner—Robin V. Taylor

(74) *Attorney, Agent, or Firm*—Alston & Bird LLP

(56) **References Cited**

(57) **CLAIM**

The ornamental design for a pipe gland, as shown and
 described.

U.S. PATENT DOCUMENTS

DESCRIPTION

D16,160 S	7/1885	Crane	
1,940,729 A	12/1933	Pfefferle	
2,288,904 A	7/1942	Hudson	
2,412,487 A	12/1946	Amley et al.	
2,792,240 A	5/1957	Risley et al.	
2,861,822 A	* 11/1958	Risley et al.	285/348
3,065,000 A	11/1962	Stanton	
D208,388 S	8/1967	Graham	
3,334,661 A	* 8/1967	Millette	138/89
3,433,509 A	3/1969	Jeffery et al.	
3,726,549 A	* 4/1973	Bradley, Jr.	285/356
3,936,451 A	2/1976	Orem et al.	
3,964,521 A	6/1976	Kao et al.	
3,964,522 A	6/1976	Kao et al.	
D240,428 S	7/1976	Hoffman	
4,007,298 A	2/1977	Feehan et al.	
4,014,827 A	3/1977	Hart et al.	
4,026,586 A	5/1977	Kennedy, Jr. et al.	
4,108,481 A	8/1978	Graham	
4,113,286 A	9/1978	Kennedy, Jr.	
4,128,265 A	12/1978	Fenster et al.	
4,280,732 A	7/1981	Haspert	

FIG. 1 is a perspective view of a pipe gland according to the
 present design;
 FIG. 2 is a front elevation view of the pipe gland shown in
 FIG. 1;
 FIG. 3 is a section view of the pipe gland shown in FIG. 2,
 taken along section line 3—3;
 FIG. 4 is a right elevation view of the pipe gland shown in
 FIG. 1, with the left elevation view of the pipe gland shown
 in FIG. 1 being a mirror image of FIG. 4;
 FIG. 5 is a bottom plan view of the pipe gland shown in FIG.
 1, with the top plan view of the pipe gland shown in FIG. 1
 being a mirror image of FIG. 5; and,
 FIG. 6 is a rear elevation view of the pipe gland shown in
 FIG. 1.

The broken lines shown herein are for illustrative purposes
 only and form no part of the claimed design.

1 Claim, 6 Drawing Sheets

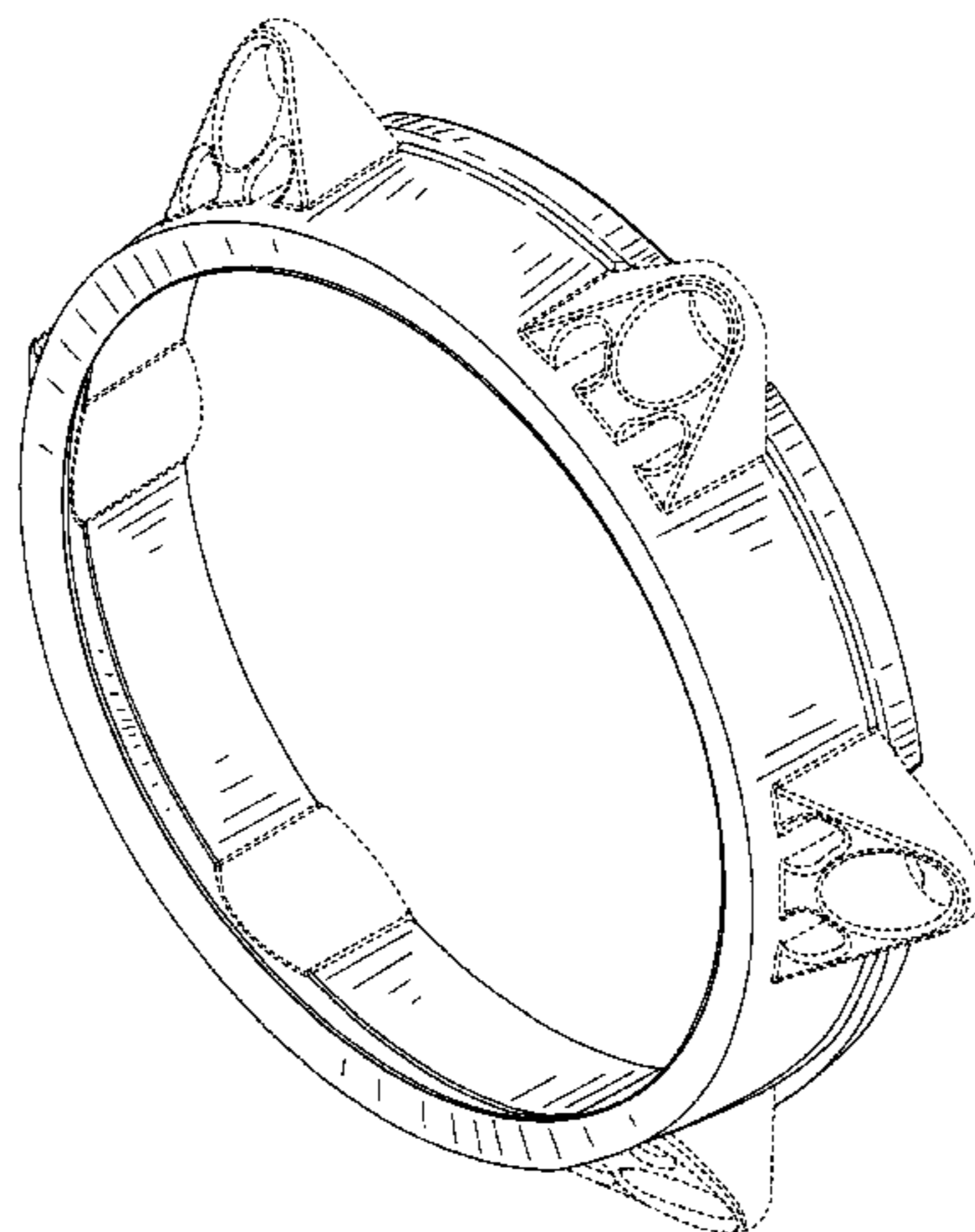

U.S. PATENT DOCUMENTS

4,437,501 A 3/1984 Canada et al.
 4,506,931 A 3/1985 Haspert
 4,532,957 A 8/1985 Battle et al.
 4,540,204 A 9/1985 Battle et al.
 D284,022 S 5/1986 Milot et al.
 4,660,866 A 4/1987 Jones et al.
 4,685,705 A 8/1987 Jones
 D294,384 S 2/1988 Endo et al.
 4,750,194 A 6/1988 Russell
 4,756,784 A 7/1988 Jones et al.
 4,791,976 A 12/1988 Malizio et al.
 4,832,084 A 5/1989 Malizio et al.
 4,867,488 A 9/1989 Jones
 4,871,197 A 10/1989 Coddington, III et al.
 4,878,698 A 11/1989 Gilchrist
 D310,868 S 9/1990 Wilder
 5,067,751 A 11/1991 Walworth et al.
 D339,975 S * 10/1993 Bird et al. D8/354
 5,269,569 A 12/1993 Weber et al.
 5,295,697 A 3/1994 Weber et al.
 5,335,946 A 8/1994 Dent et al.
 5,336,998 A 8/1994 Watts et al.
 5,398,980 A 3/1995 Hunter et al.

5,464,228 A 11/1995 Weber et al.
 D390,923 S * 2/1998 Stevens D23/262
 D397,090 S 8/1998 Gray
 5,803,513 A 9/1998 Richardson
 6,214,203 B1 4/2001 Horton
 6,289,600 B1 9/2001 Watts
 6,331,242 B1 12/2001 Horton
 D453,816 S * 2/2002 Sato et al. D23/262
 6,497,151 B1 12/2002 Watts et al.
 6,502,867 B2 1/2003 Holmes, IV et al.

OTHER PUBLICATIONS

American National Standards Institute; American National Standard for Rubber-Gasket Joints for Ductile-Iron Pressure Pipe and Fittings; ANSI/AWWA C111/A21.11-00; Dated Jan. 23, 2003; §4.1-4.4; American Water Works Association.

American National Standards Institute; American National Standard for Ductile-Iron Compact Fittings for Water Service; ANSI/AWWA C153/A21.53-00; Dated 2000; Figure 1; American Water Works Association.

* cited by examiner

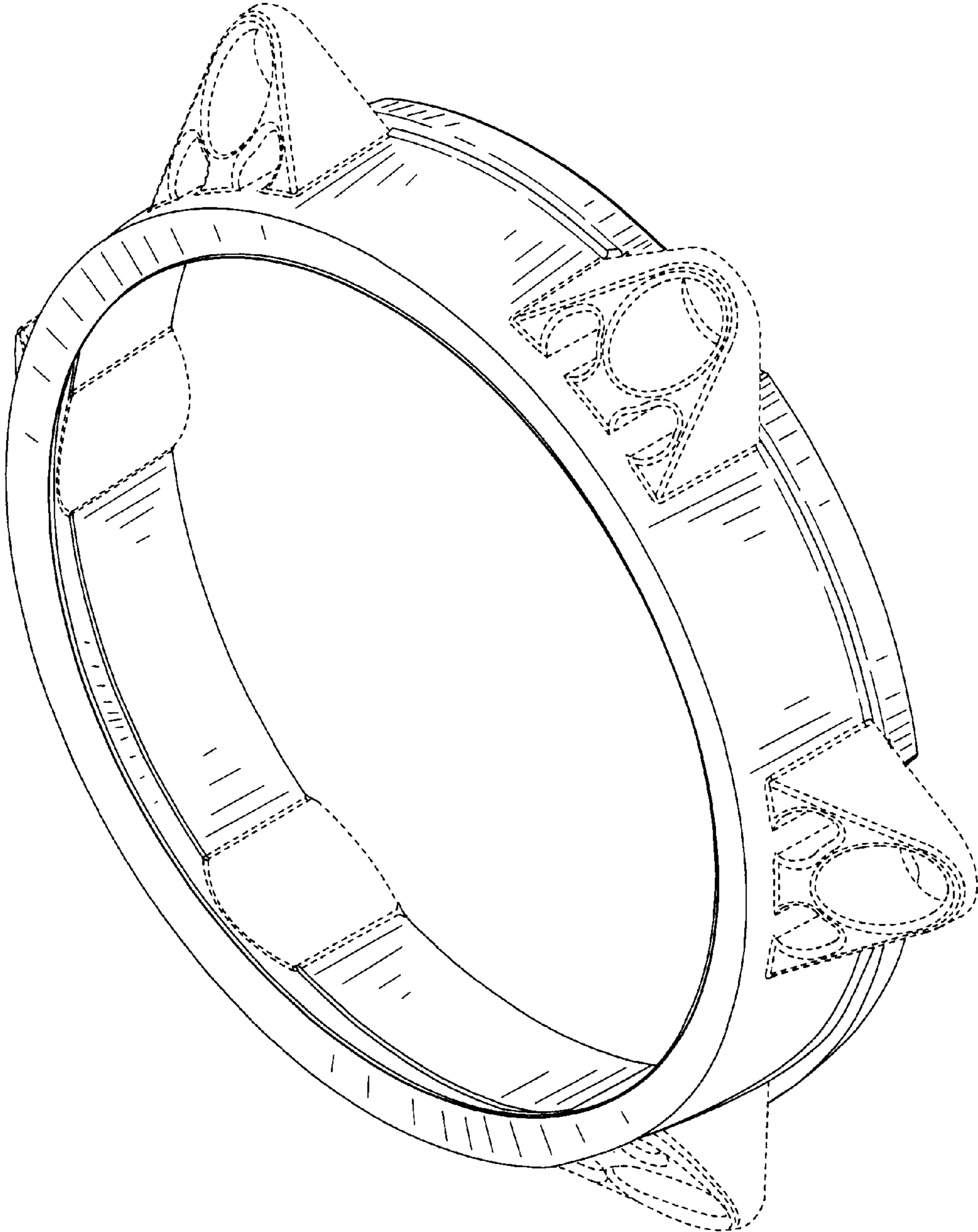

FIG. 1

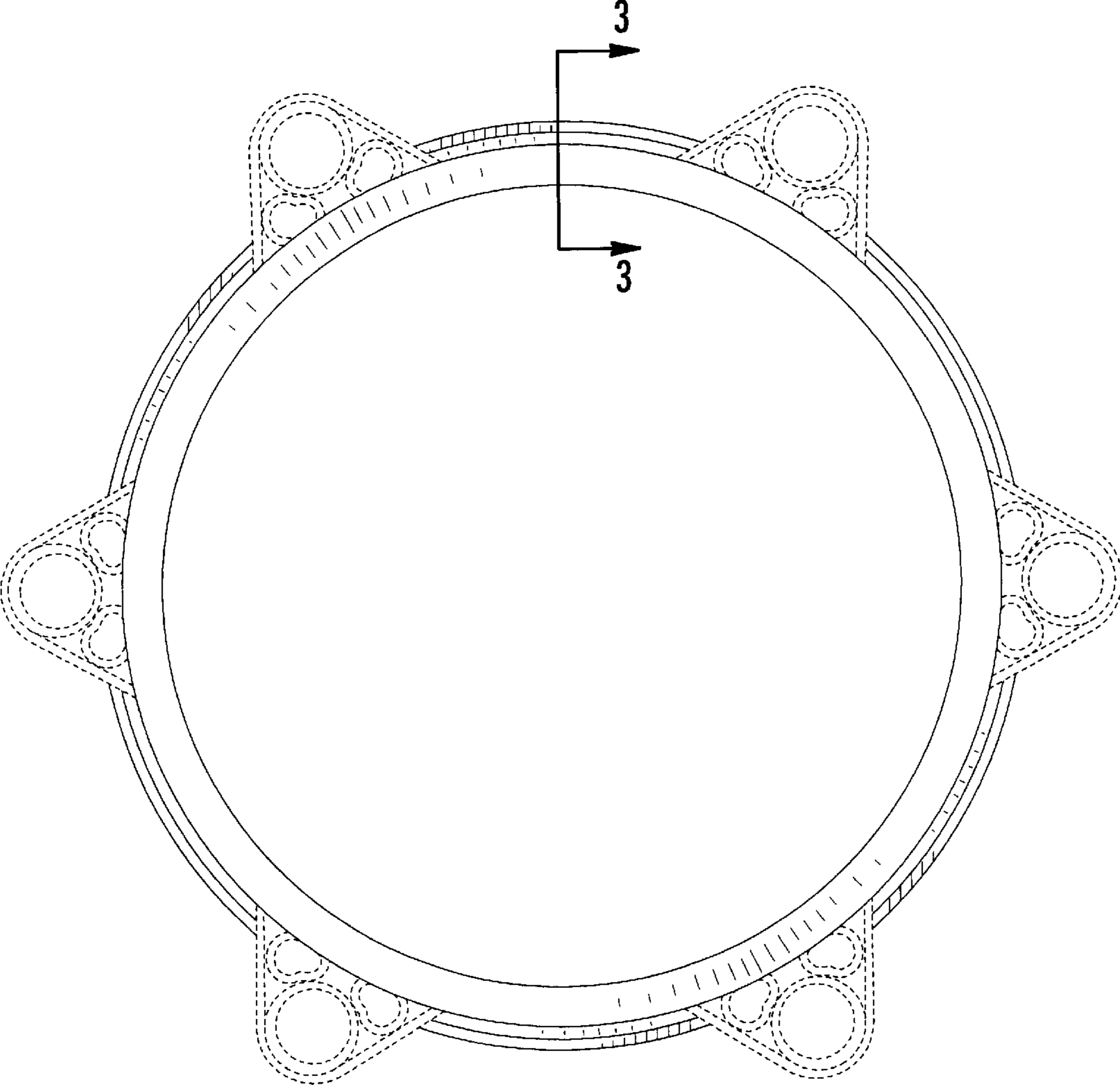

FIG. 2

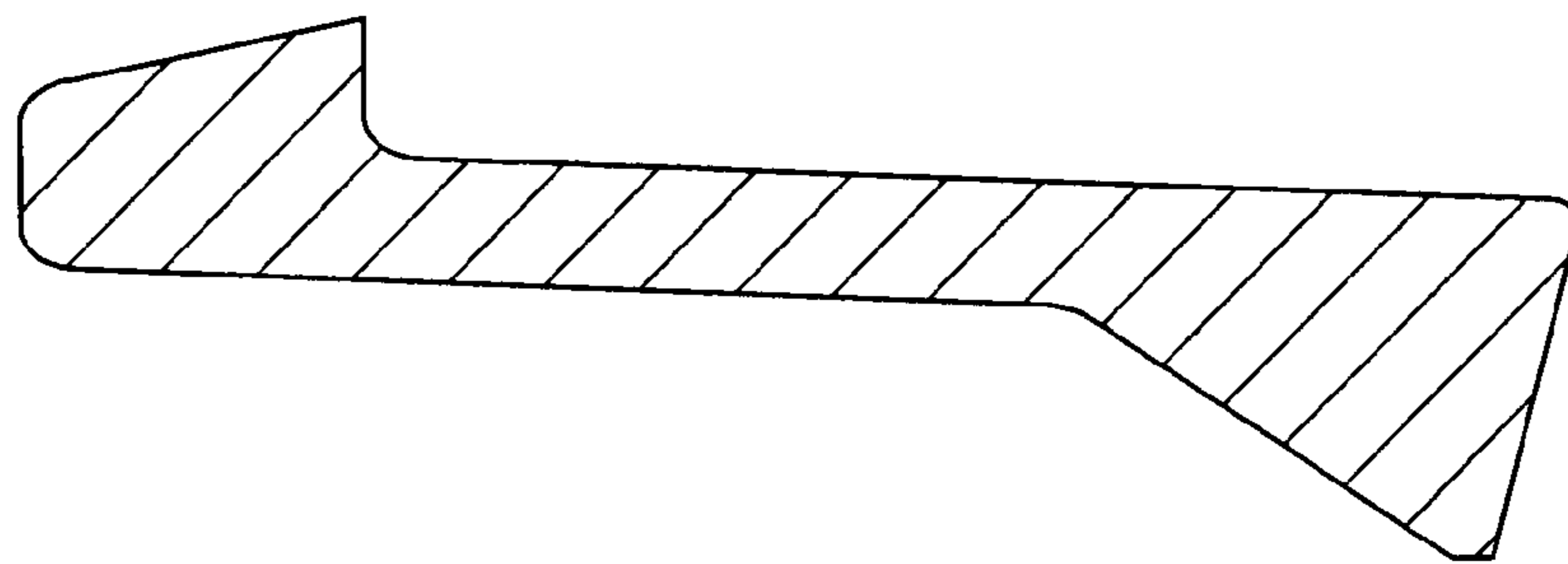

FIG. 3

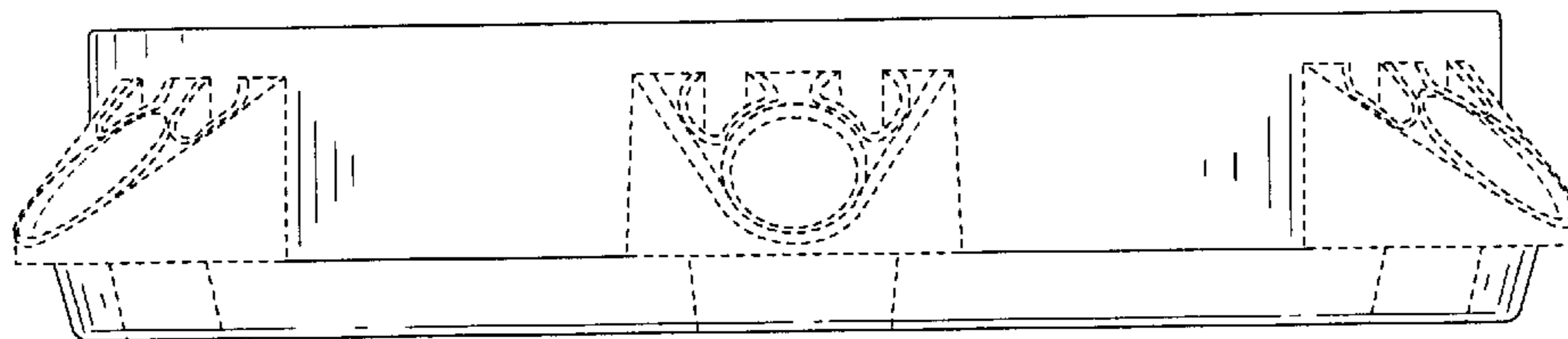

FIG. 4

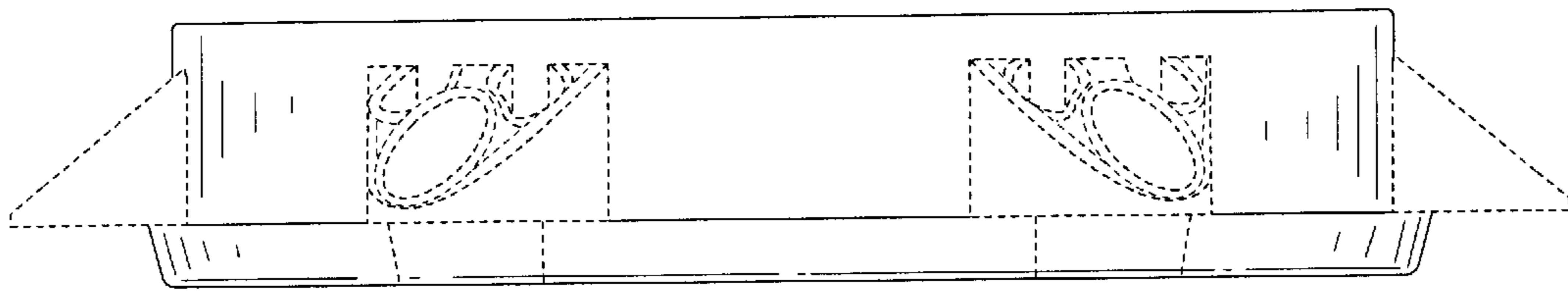

FIG. 5

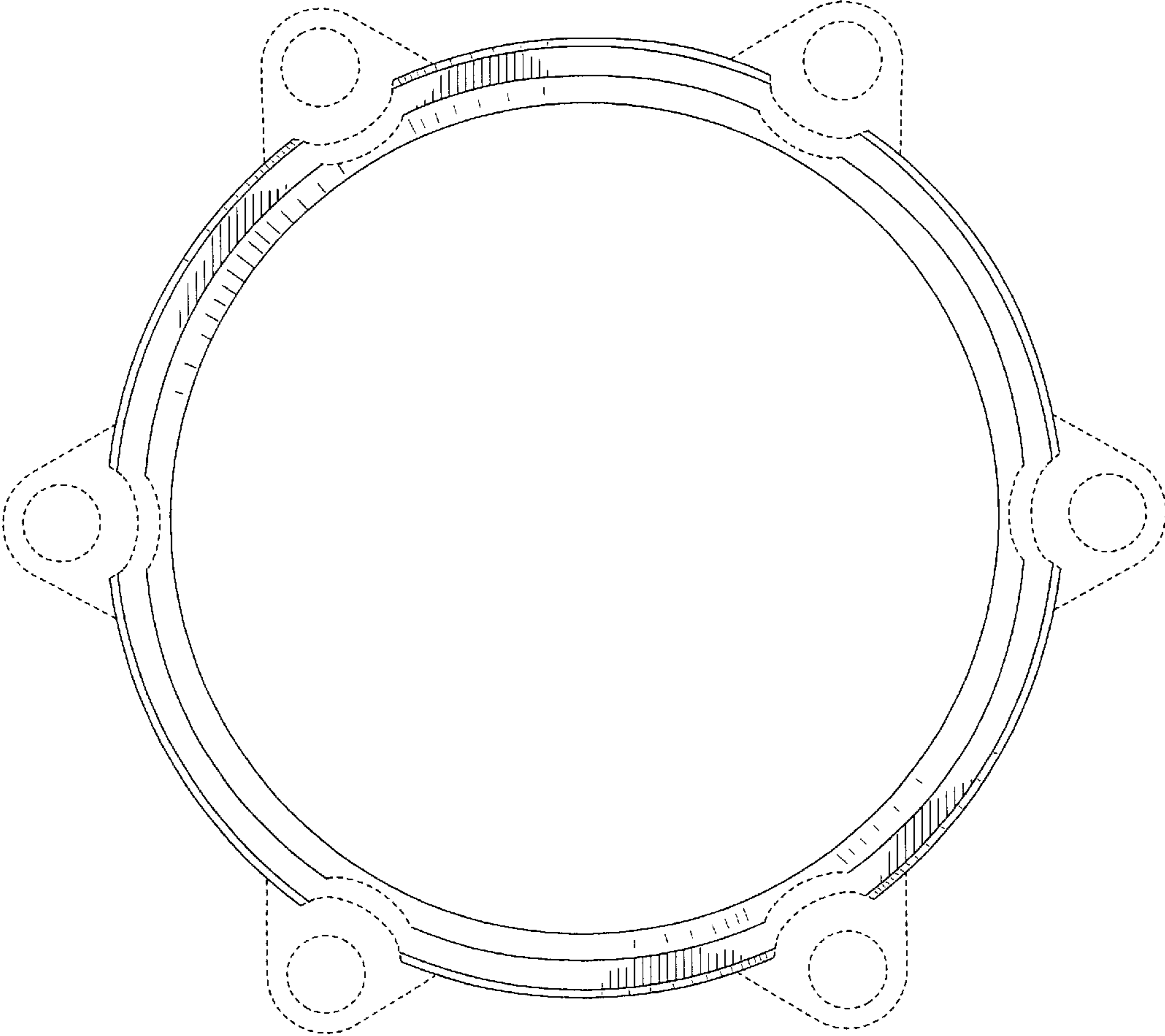

FIG. 6