



US00D513415S

(12) **United States Design Patent**  
**Klein et al.**

(10) **Patent No.: US D513,415 S**  
(45) **Date of Patent: \*\* Jan. 3, 2006**

(54) **COCKPIT OF A CONSTRUCTION VEHICLE**

(75) Inventors: **Thomas Klein, Wehr (DE); Roland Loew, Klein-Winternheim (DE)**

(73) Assignee: **Bomag GmbH, Boppard (DE)**

(\*\*) Term: **14 Years**

(21) Appl. No.: **29/213,775**

(22) Filed: **Sep. 23, 2004**

(30) **Foreign Application Priority Data**

Mar. 23, 2004 (EM) ..... 000155403

(51) **LOC (8) Cl. .... 15-03**

(52) **U.S. Cl. .... D15/30**

(58) **Field of Classification Search** ..... D15/10,  
D15/22-26, 28, 30; D21/329; 180/89.1, 326,  
180/315, 329; 296/190.01, 190.03, 190.08,  
296/202

See application file for complete search history.

(56) **References Cited**

**U.S. PATENT DOCUMENTS**

4,055,230 A \* 10/1977 Kestian et al. .... 180/89.1

4,478,308 A \* 10/1984 Klaassen ..... 180/326

4,600,236 A \* 7/1986 Weiss et al. .... 296/190.03  
5,924,515 A \* 7/1999 Stauffer ..... 180/326  
D420,685 S \* 2/2000 Muranen ..... D15/30  
6,039,141 A \* 3/2000 Denny ..... 180/329  
D463,459 S \* 9/2002 Tamaru et al. .... D15/28  
6,634,453 B2 \* 10/2003 Arthur et al. .... 180/315  
D497,394 S \* 10/2004 Svanson et al. .... D21/329

\* cited by examiner

*Primary Examiner*—Stella Reid

*Assistant Examiner*—Mark A. Goodwin

(74) *Attorney, Agent, or Firm*—Baker & Hostetler LLP

(57) **CLAIM**

The ornamental design for a cockpit of a construction vehicle, as shown and described.

**DESCRIPTION**

FIG. 1 is a top right side perspective view of a cockpit of a construction vehicle showing our new design; FIG. 2 is a right side view thereof; FIG. 3 is a top left side view thereof; FIG. 4 is a left side view thereof; FIG. 5 is a top view thereof; FIG. 6 is a front left side perspective view thereof; and, FIG. 7 is a rear right side perspective view thereof.

**1 Claim, 7 Drawing Sheets**

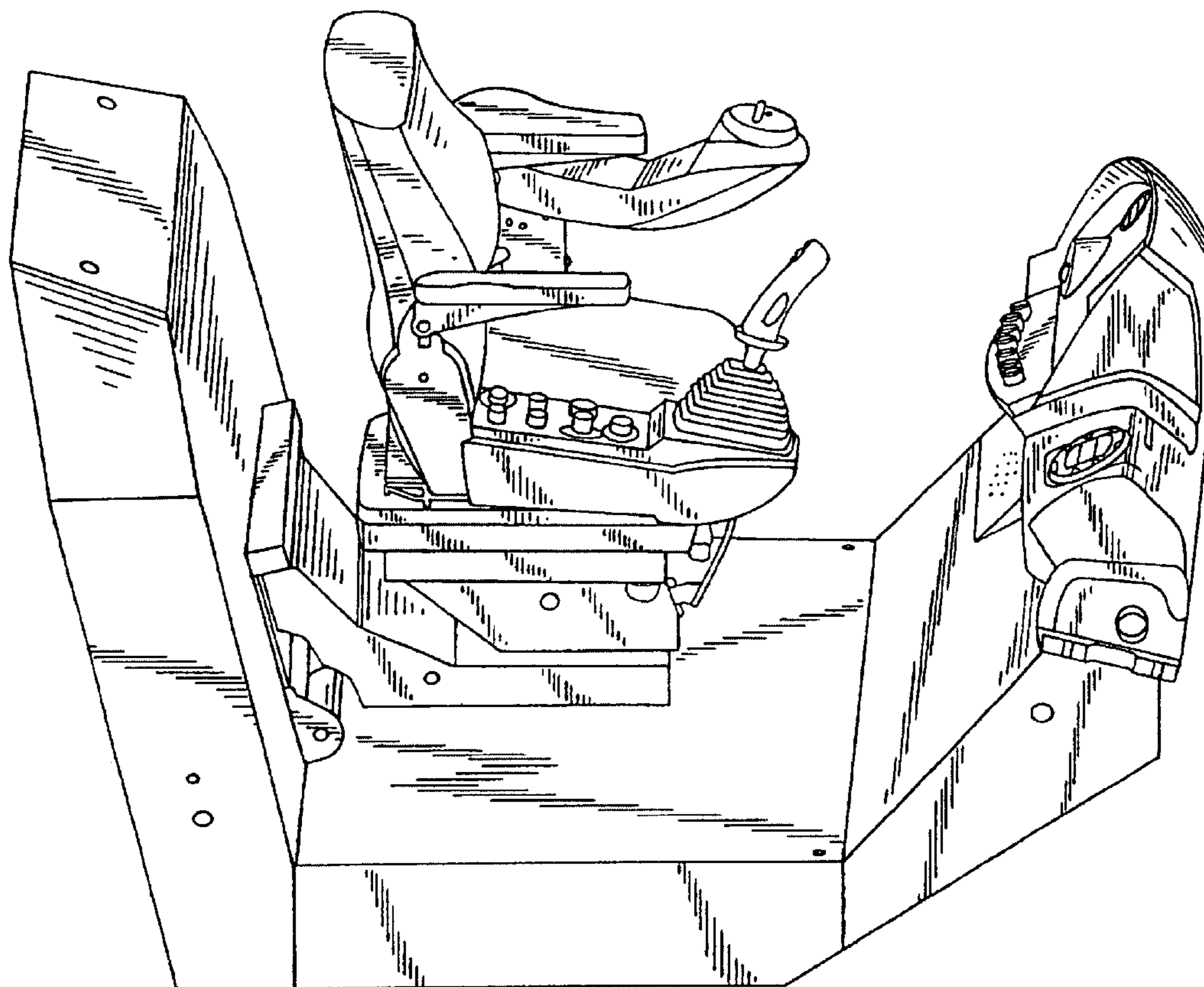

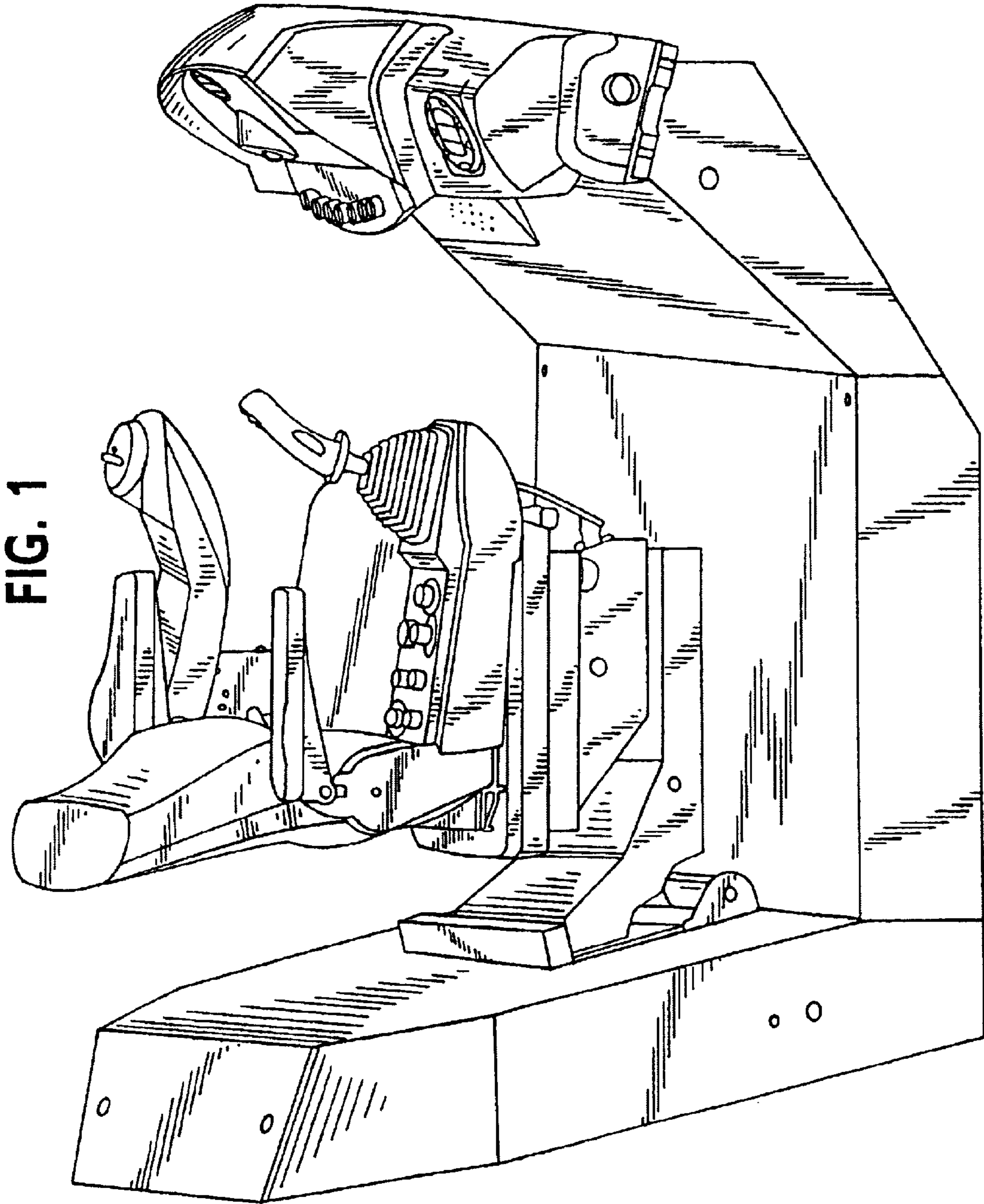
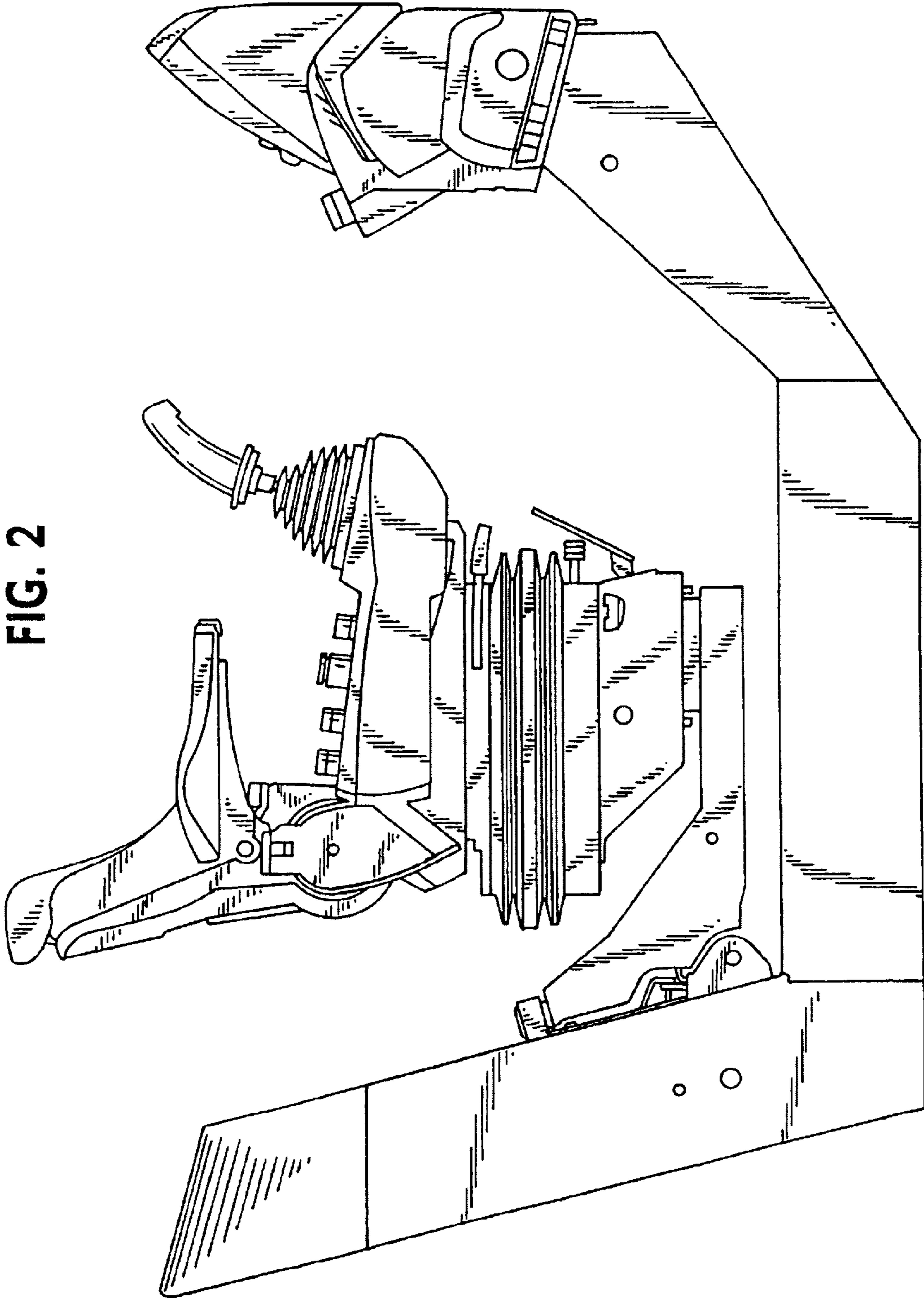

FIG. 1





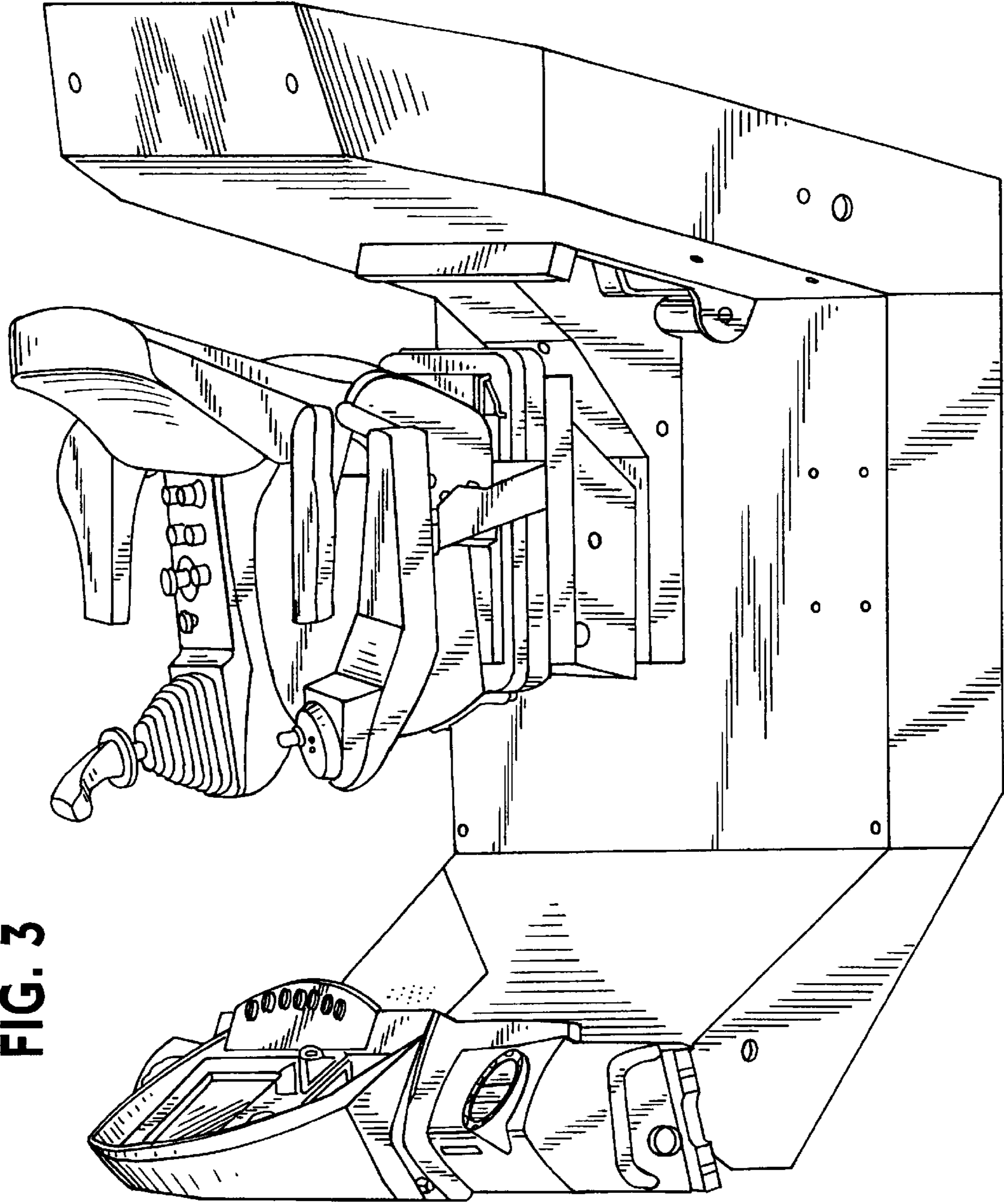
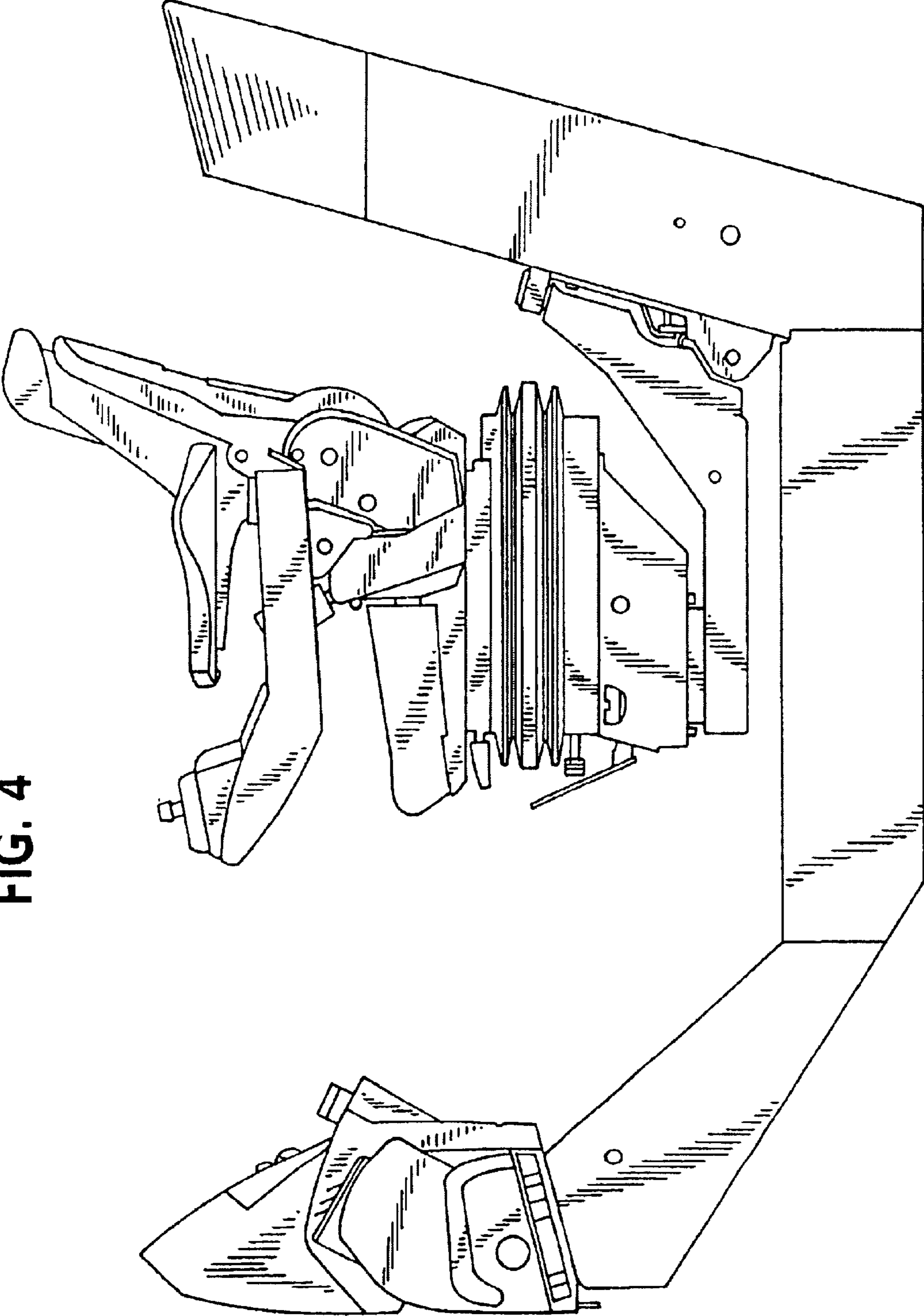

FIG. 3

FIG. 4



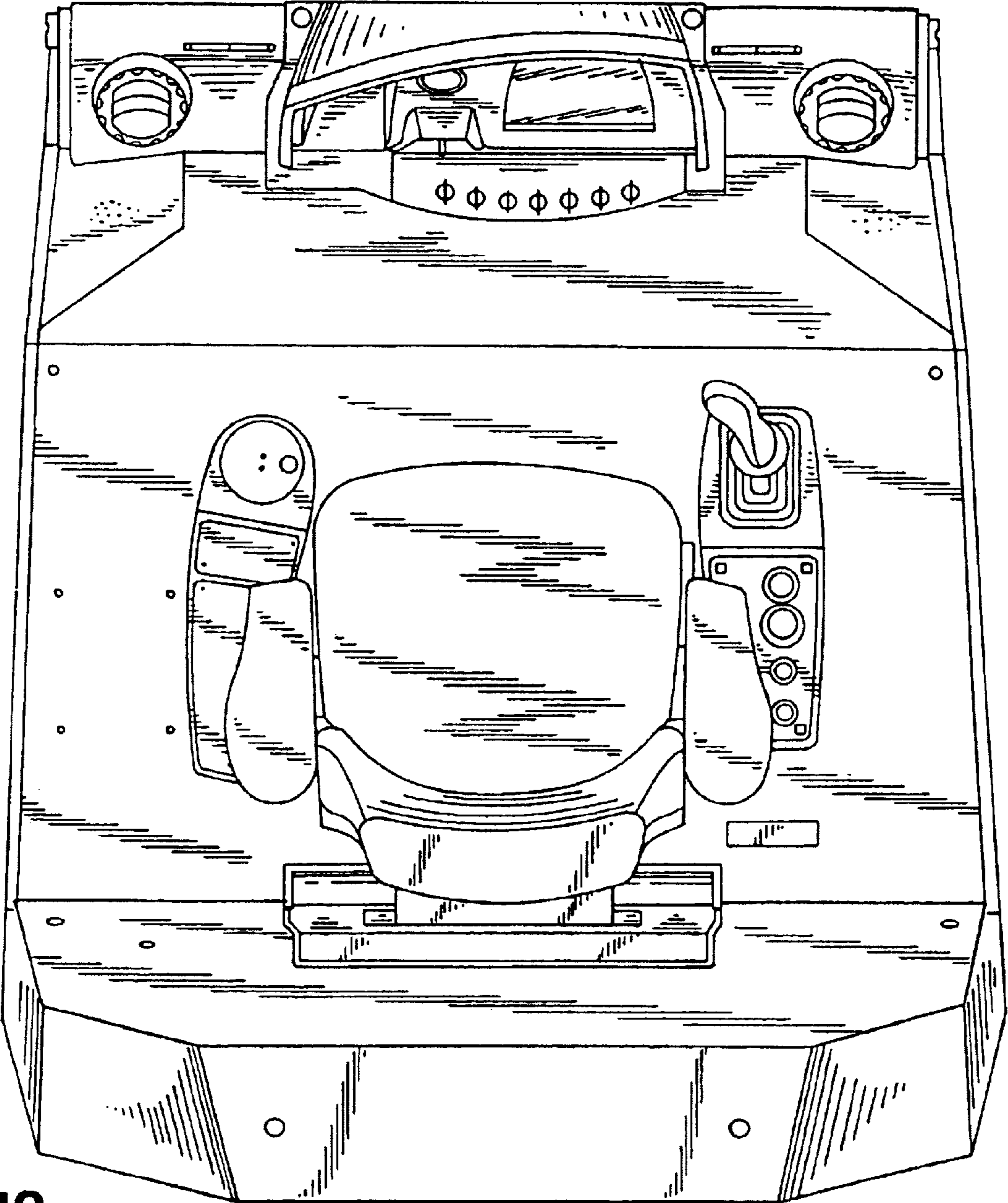

FIG. 5

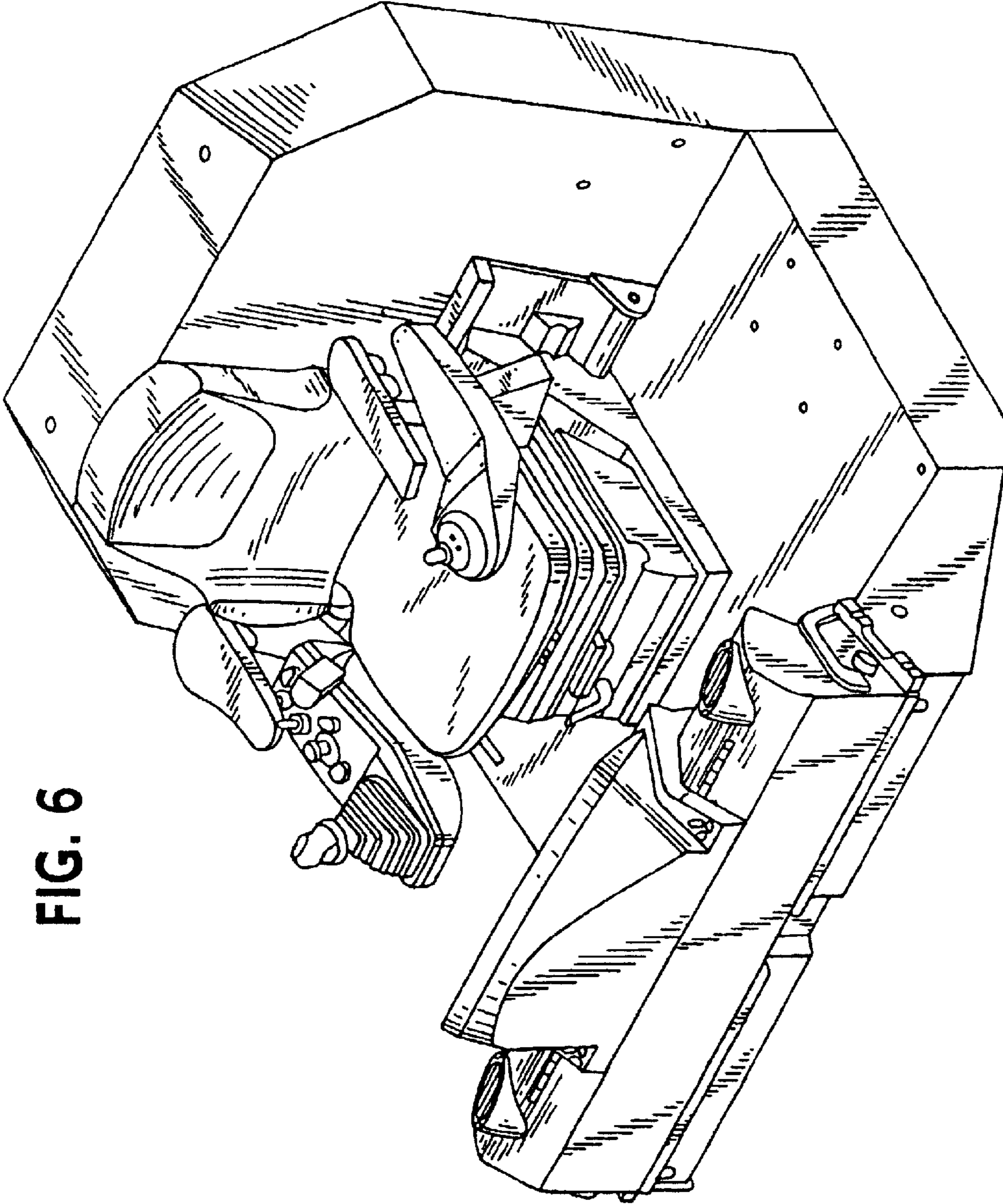

FIG. 6



FIG. 7

