



US00D513223S

(12) **United States Design Patent** (10) **Patent No.:** **US D513,223 S**
Saito et al. (45) **Date of Patent:** **** Dec. 27, 2005**

(54) **CABIN FRAME FOR FOUR-WHEELED UTILITY VEHICLE WITH FRONT AND REAR SEATS**

www.polarispowersports.com/rang/polrangers.html, "Polaris Rangers," (1 page) Sep. 23, 2004.

(75) Inventors: **Hideo Saito**, Lincoln, NE (US);
Kazumasa Hisada, Lincoln, NE (US)

* cited by examiner

(73) Assignee: **Kawasaki Jukogyo Kabushiki Kaisha**,
Kobe (JP)

Primary Examiner—Nelson C. Holtje
(74) *Attorney, Agent, or Firm*—Alleman Hall McCoy
Russell & Tuttle LLP

(**) Term: **14 Years**

(57) **CLAIM**

(21) Appl. No.: **29/213,921**

The ornamental design for a cabin frame for four-wheeled utility vehicle with front and rear seats, as shown and described.

(22) Filed: **Sep. 24, 2004**

(51) **LOC (6) Cl.** **12-06**

(52) **U.S. Cl.** **D12/222; D12/14**

(58) **Field of Search** D12/1, 14, 16,
D12/222; 296/77.1

DESCRIPTION

(56) **References Cited**

U.S. PATENT DOCUMENTS

3,622,177	A	*	11/1971	Notestine et al.	280/756
D262,790	S	*	1/1982	Bernier	D12/222
5,086,858	A	*	2/1992	Mizuta et al.	180/68.3
5,174,622	A	*	12/1992	Gutta	296/77.1
D433,651	S	*	11/2000	Matsumura et al.	D12/1
D439,548	S		3/2001	Kouchi et al.		
6,523,879	B2	*	2/2003	Mizuta	296/71
D478,025	S	*	8/2003	Cartwright	D12/107

FOREIGN PATENT DOCUMENTS

JP 1187561 10/2003

OTHER PUBLICATIONS

www.polarispowersports.com, "Welcome to Polaris Powersports," (2 pages) Sep. 23, 2004.
www.polarispowersports.com/atvbods.html, "Polaris ATV Body Styles Guide," (5 pages) Sep. 23, 2004.

FIG. 1 is an isometric view of a cabin frame for a four-wheeled utility vehicle with front and rear seats, according to one embodiment of the present invention.

FIG. 2 is a left side view of the cabin frame of FIG. 1, showing the cabin frame attached to a four-wheeled utility vehicle with front and rear seats.

FIG. 3 is a left side view of the cabin frame of FIG. 1.

FIG. 4 is a right side view of the cabin frame of FIG. 1.

FIG. 5 is a top view of the cabin frame of FIG. 1.

FIG. 6 is a bottom view of the cabin frame of FIG. 1.

FIG. 7 is a front view of the cabin frame of FIG. 1; and,

FIG. 8 is a rear view of the cabin frame of FIG. 1.

The broken lines show environment. The broken lines form no part of the claimed design.

1 Claim, 4 Drawing Sheets

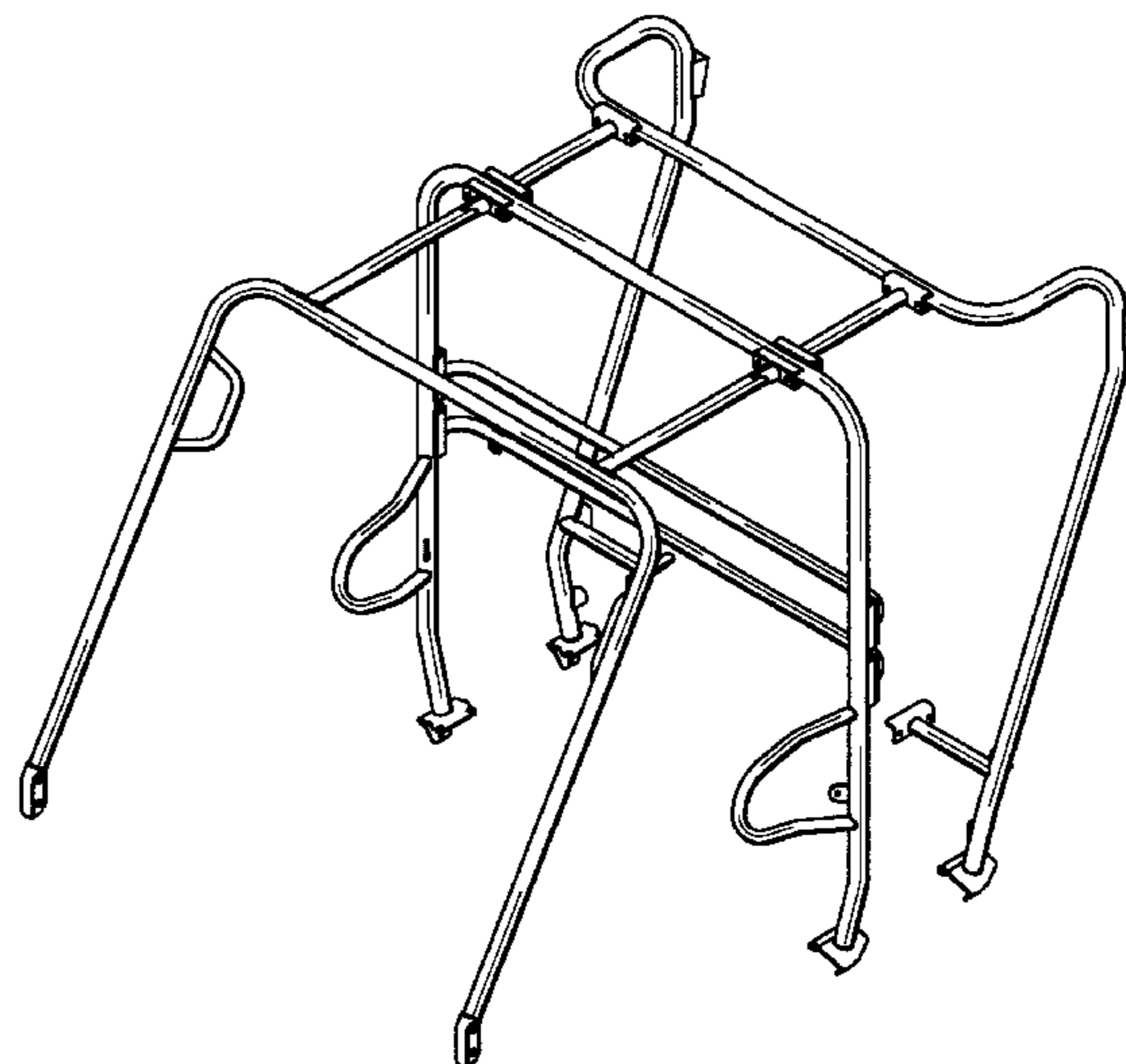

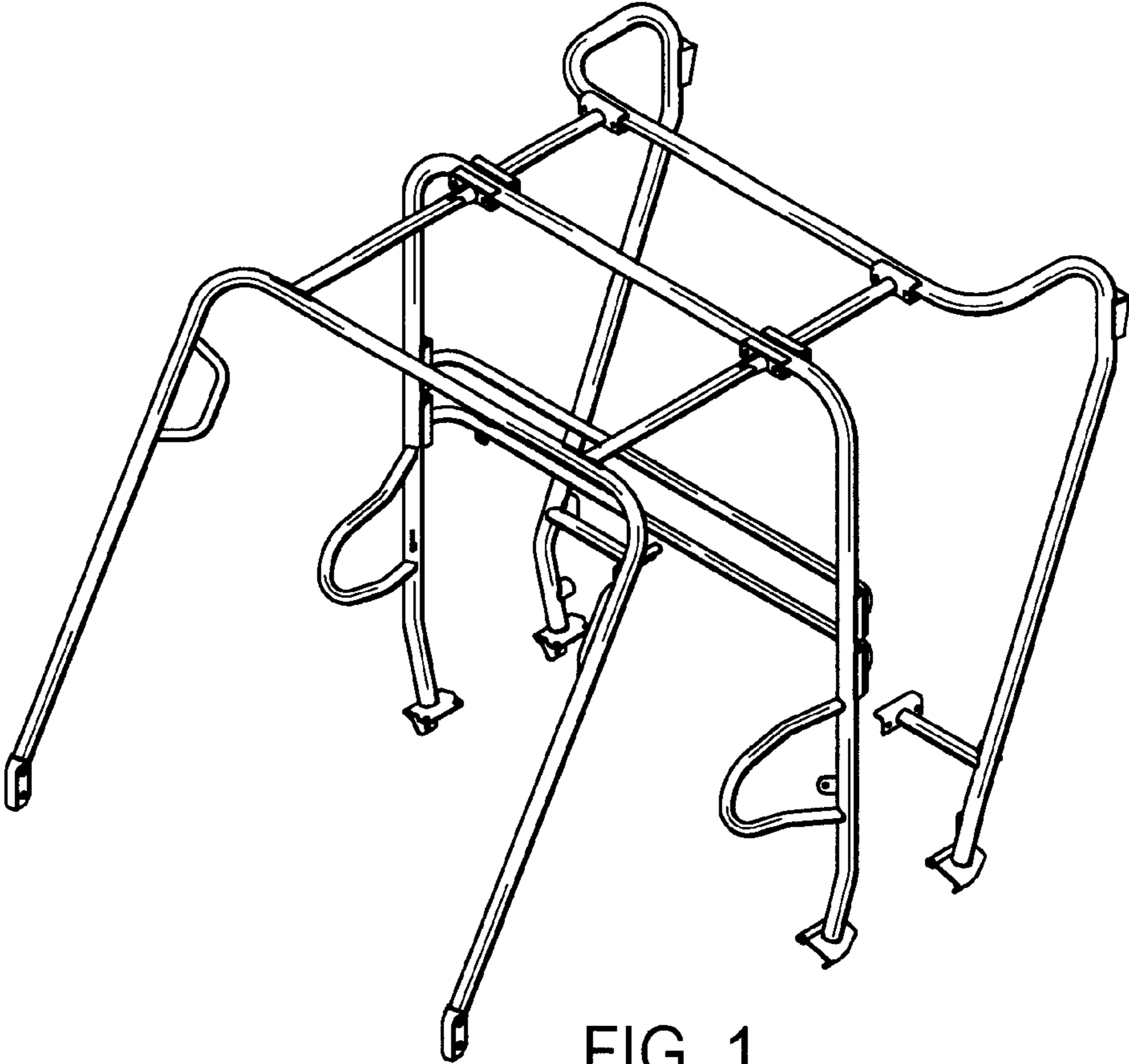

FIG. 1

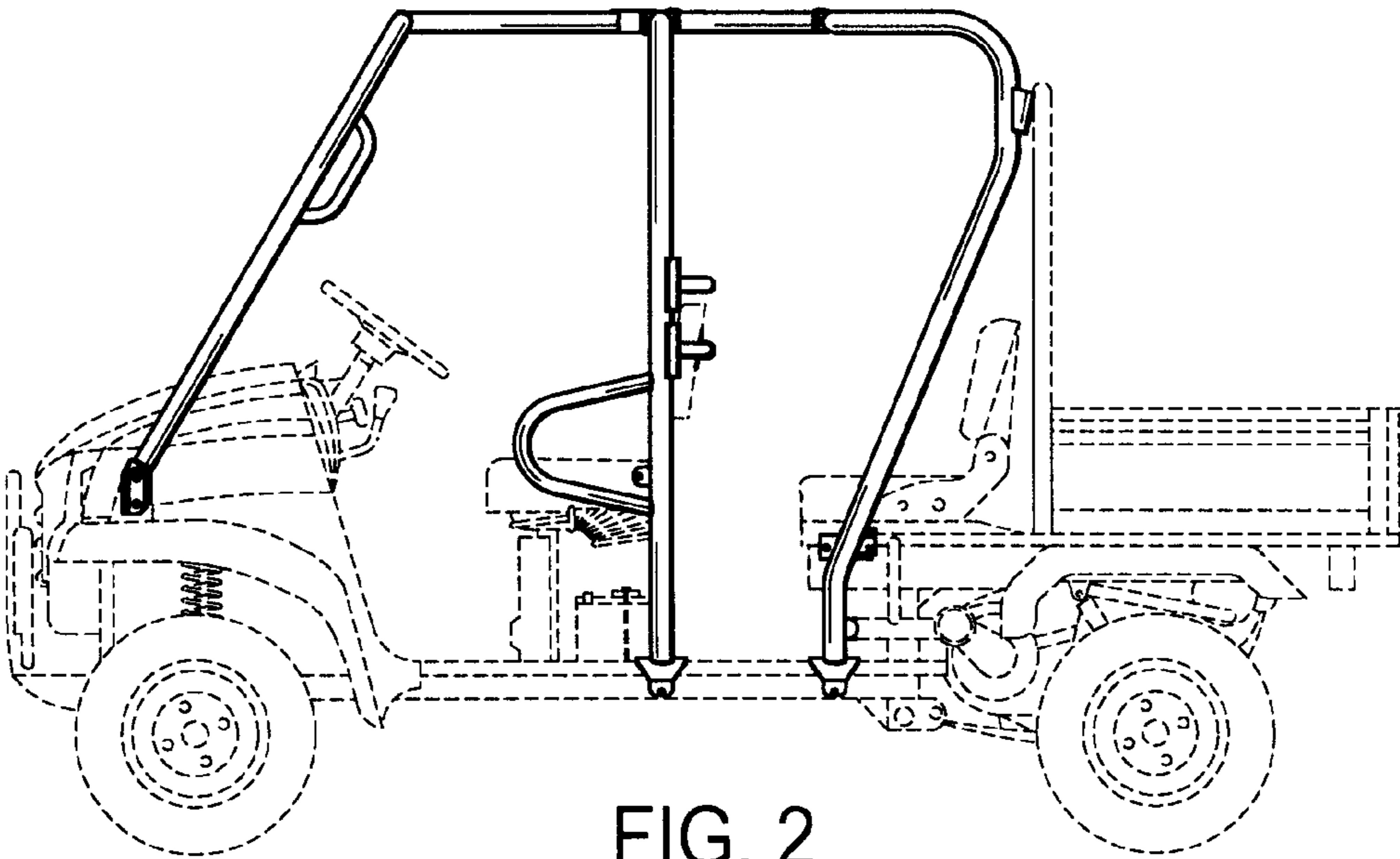

FIG. 2

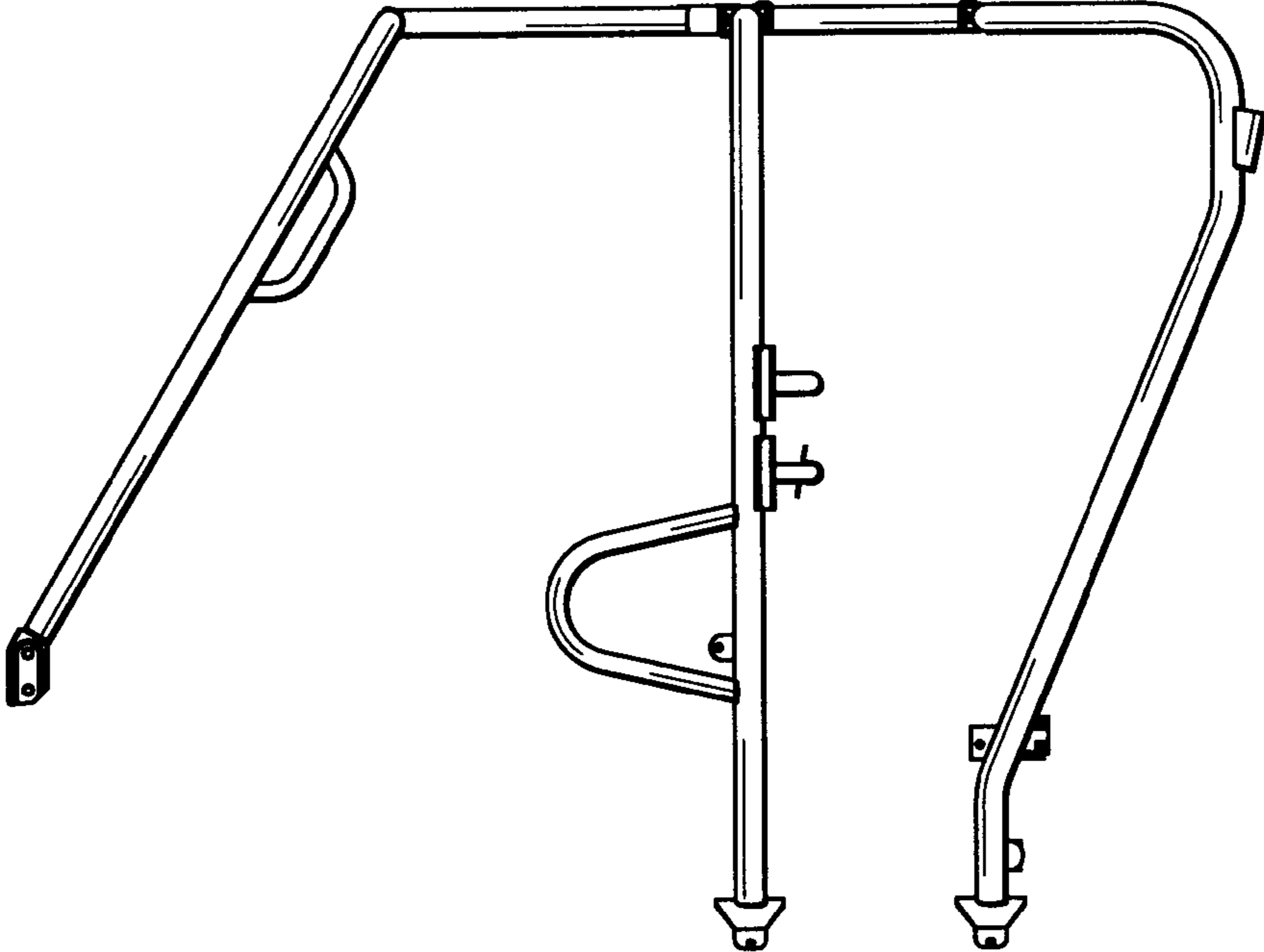

FIG. 3

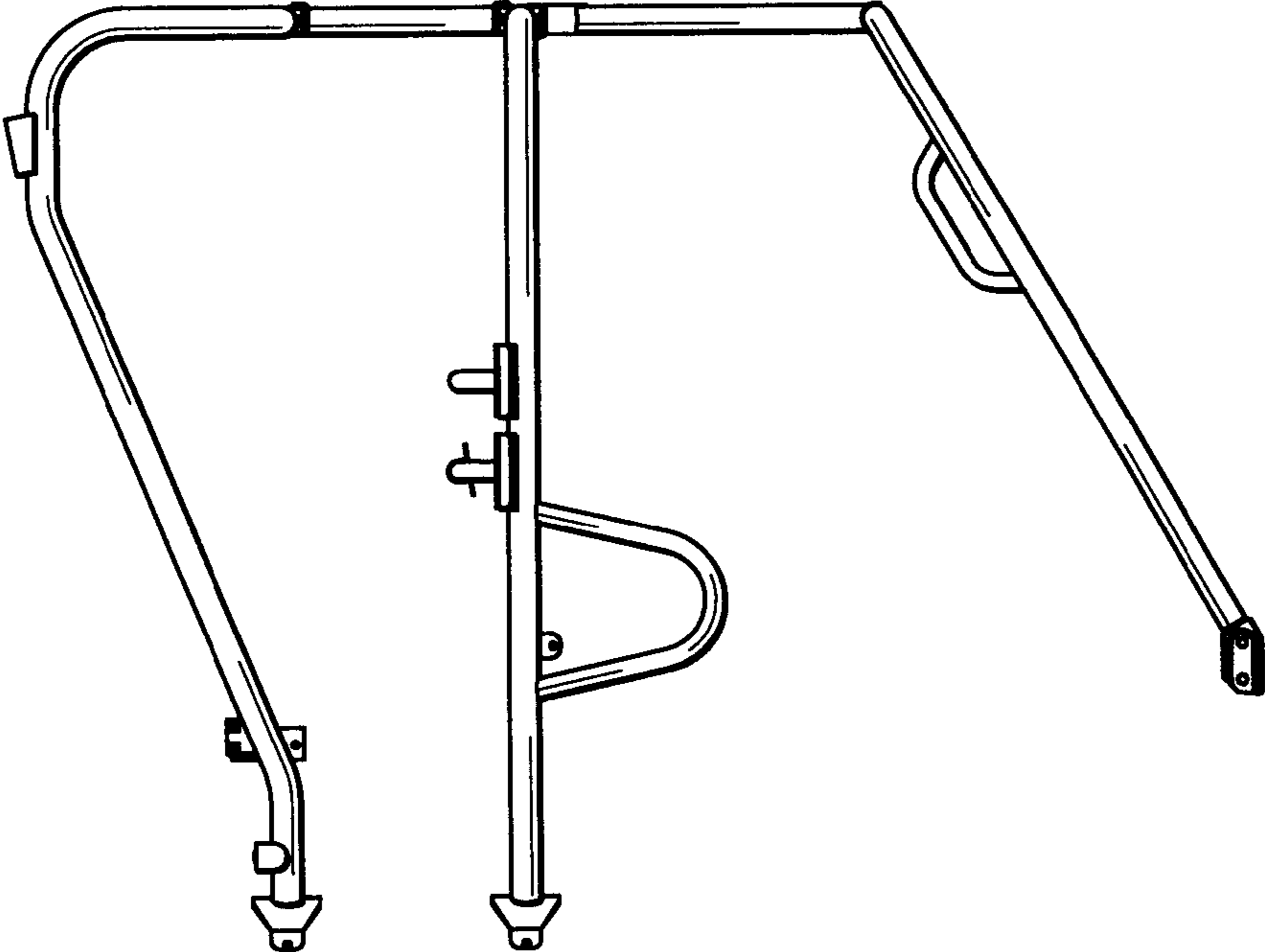

FIG. 4

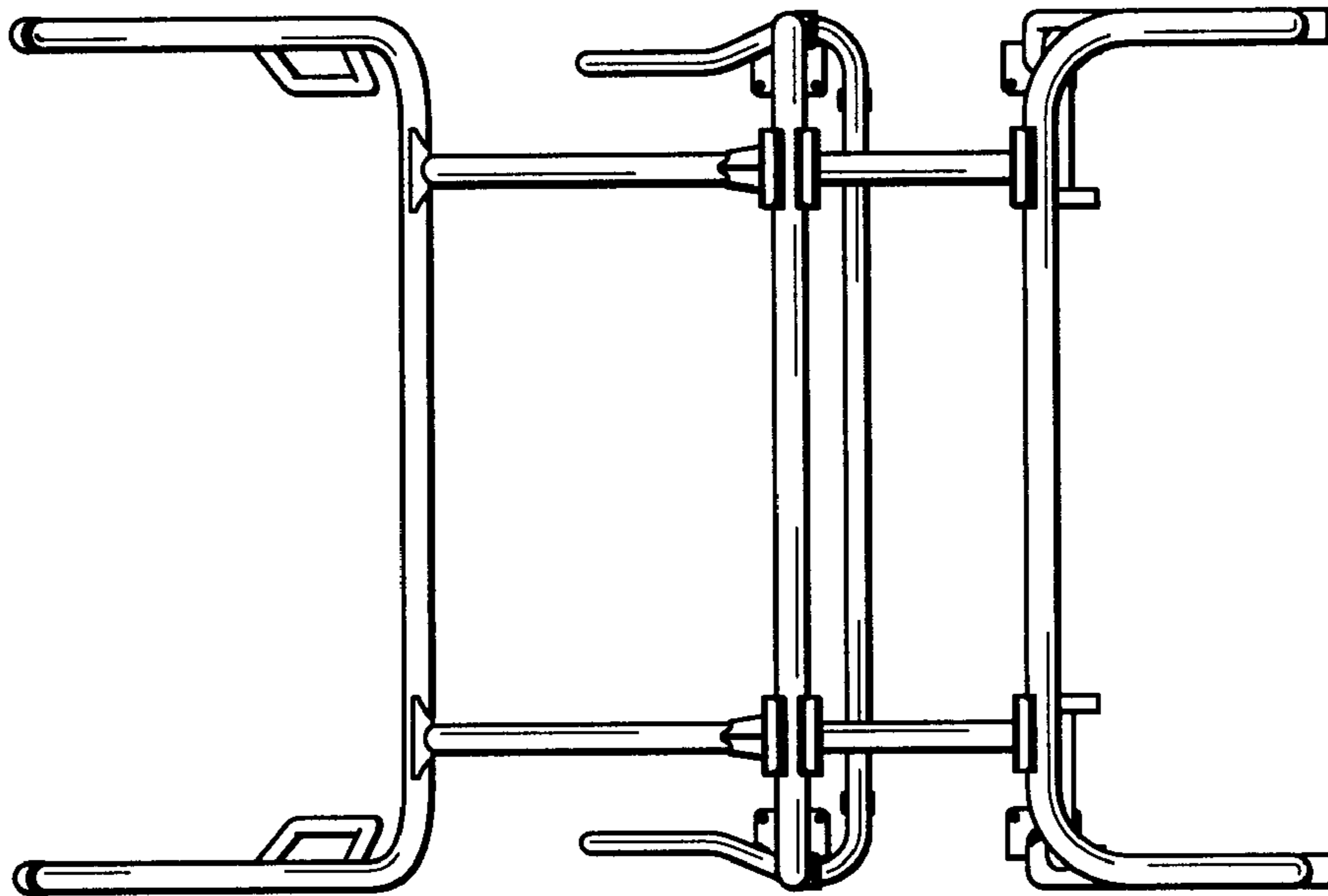

FIG. 5

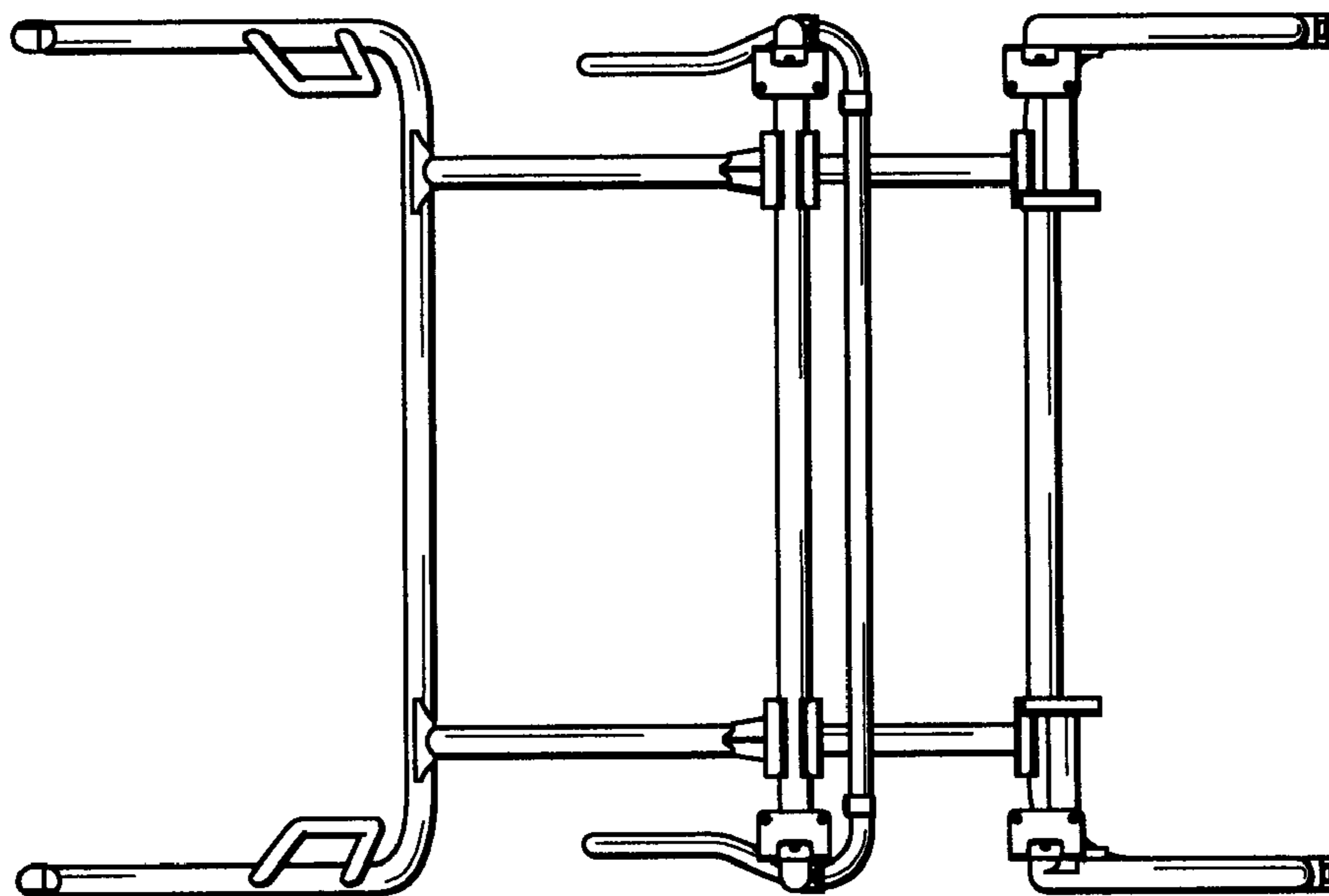

FIG. 6

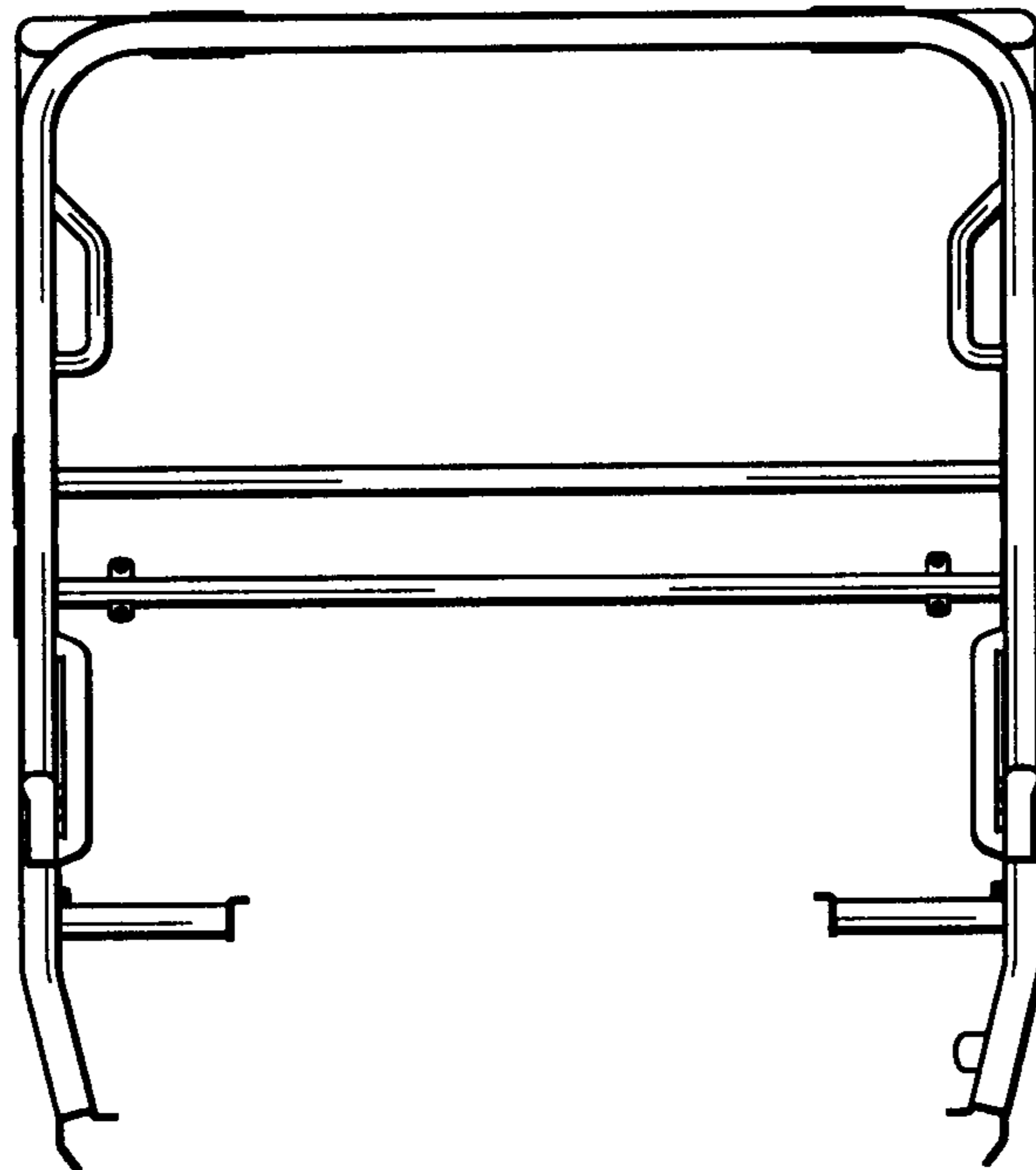

FIG. 7

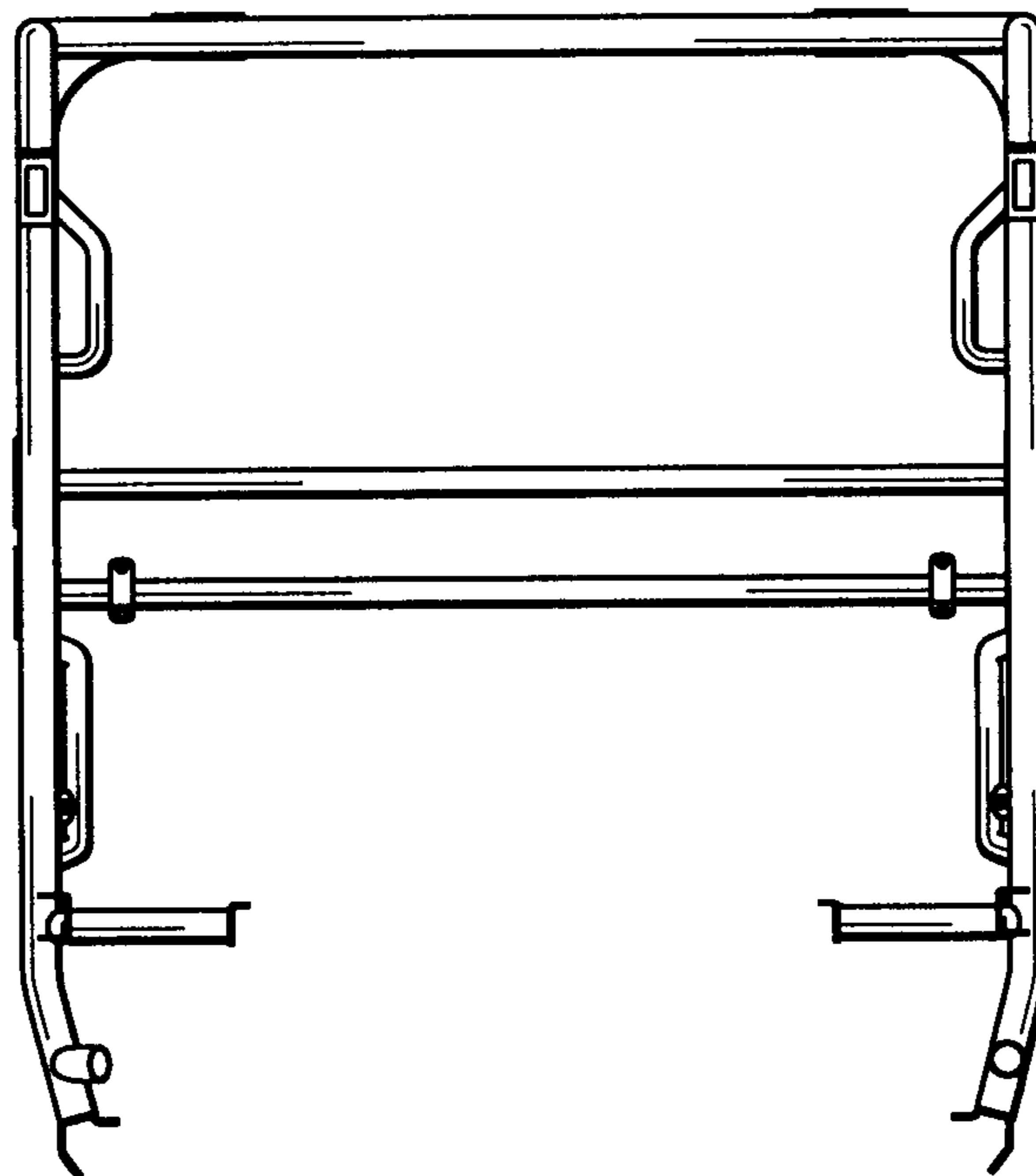

FIG. 8