



US00D513209S

(12) **United States Design Patent**
Shiau

(10) **Patent No.:** **US D513,209 S**

(45) **Date of Patent:** **** Dec. 27, 2005**

(54) **MOTORCYCLE**

(75) **Inventor:** **Chieh Hung Shiau, Kaohsiung (TW)**

(73) **Assignee:** **Keen Perception Industries Inc.,
Kaohsiung (TW)**

(**) **Term:** **14 Years**

(21) **Appl. No.:** **29/204,263**

(22) **Filed:** **Apr. 26, 2004**

(51) **LOC (6) Cl.** **12-11**

(52) **U.S. Cl.** **D12/110**

(58) **Field of Search** **D12/110; 180/219,
180/220, 225, 229**

(56) **References Cited**

U.S. PATENT DOCUMENTS

D336,450 S	*	6/1993	Tsukui et al.	D12/110
D339,088 S	*	9/1993	Tako et al.	D12/110
6,516,910 B2	*	2/2003	Buell et al.	180/219

* cited by examiner

Primary Examiner—Alan P. Douglas

Assistant Examiner—Linda Brooks

(74) *Attorney, Agent, or Firm*—Pro-Techtor International Services

(57) **CLAIM**

The ornamental design for a motorcycle, as shown and described.

DESCRIPTION

FIG. 1 is a perspective view of motorcycle showing my new design;

FIG. 2 is a right side elevation view thereof;

FIG. 3 is a left side elevation view thereof;

FIG. 4 is a front elevation view thereof

FIG. 5 is a rear elevation view thereof;

FIG. 6 is a top plan view thereof; and,

FIG. 7 is a bottom plan view thereof.

1 Claim, 7 Drawing Sheets

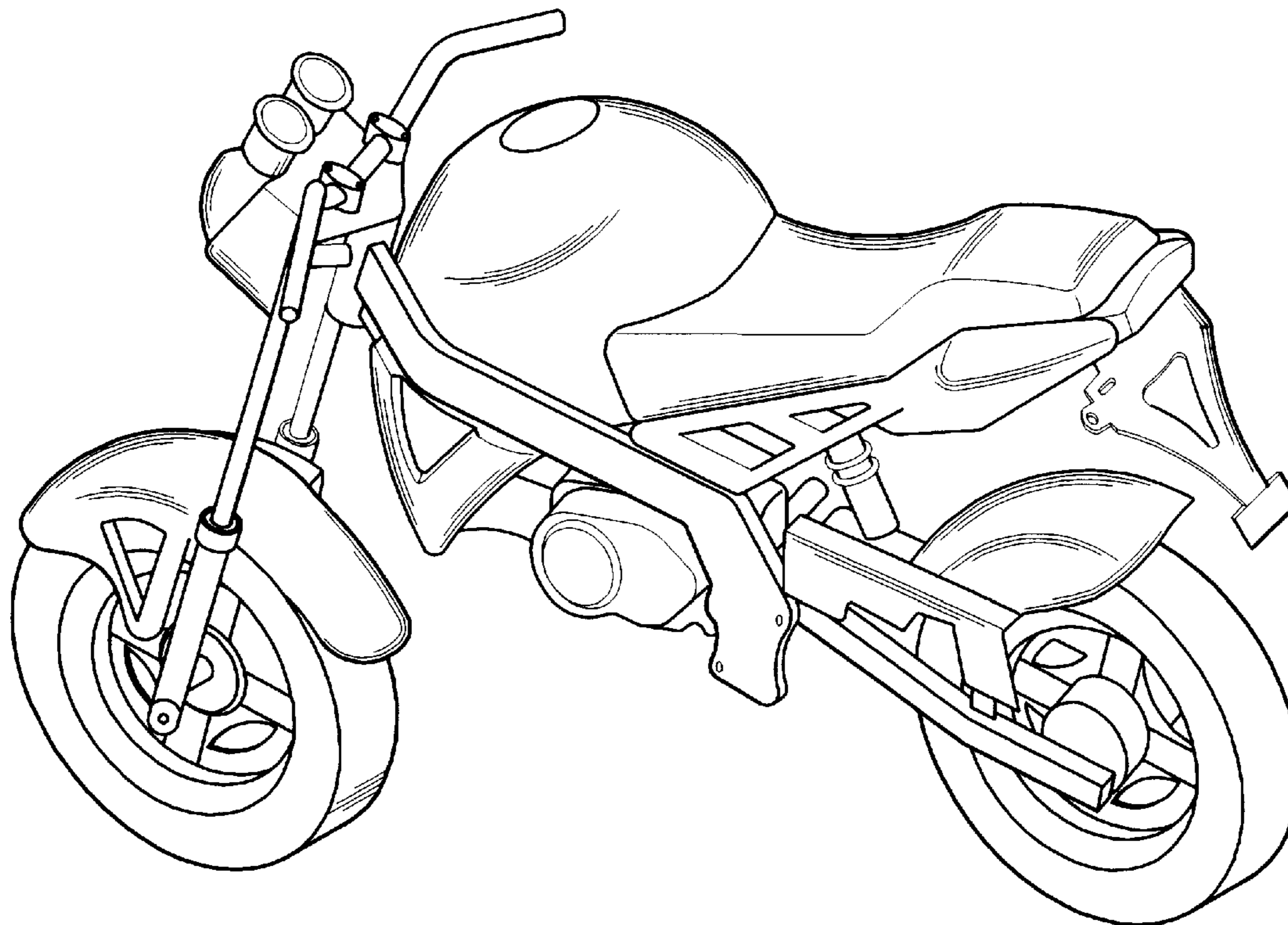

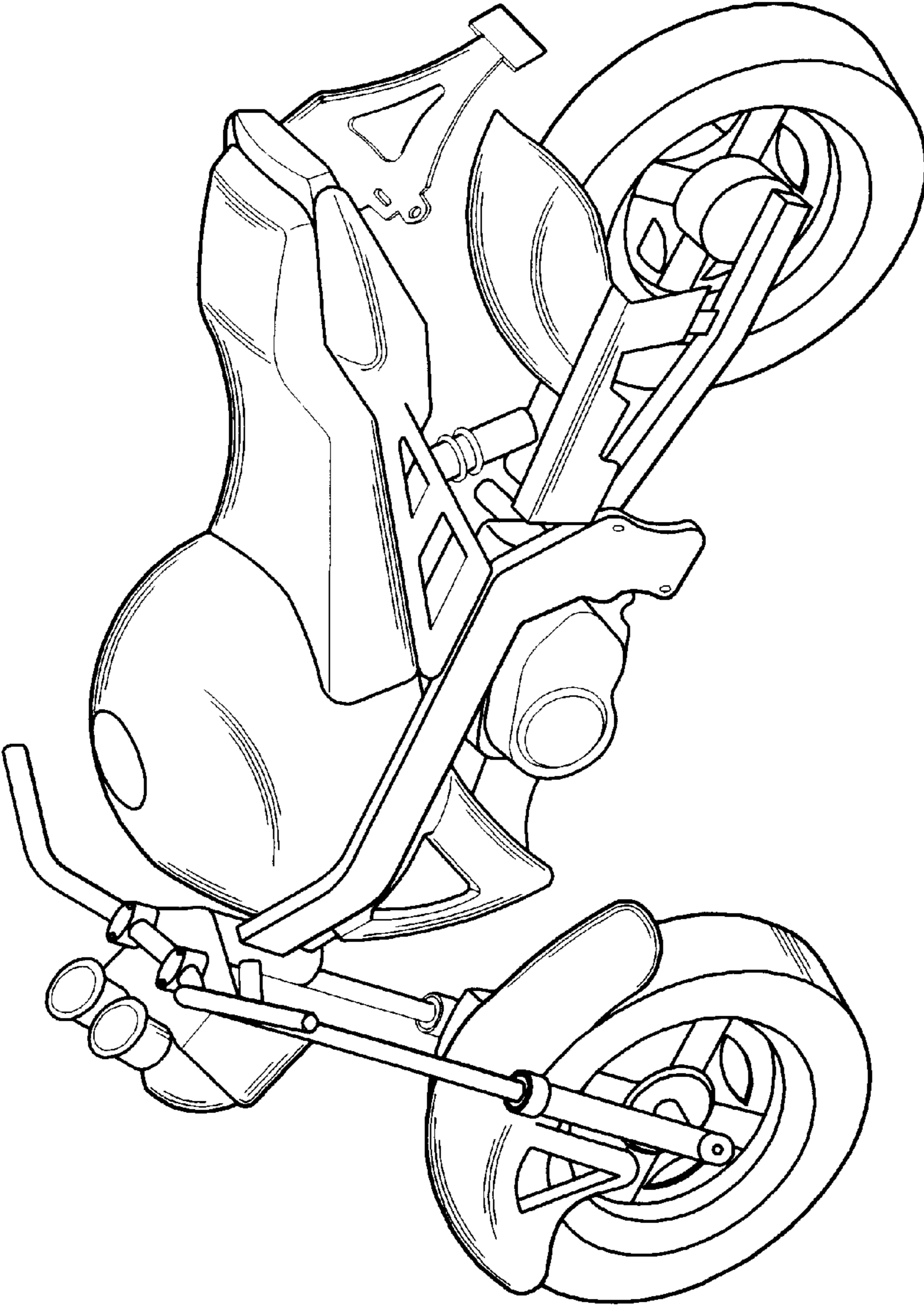

FIG. 1

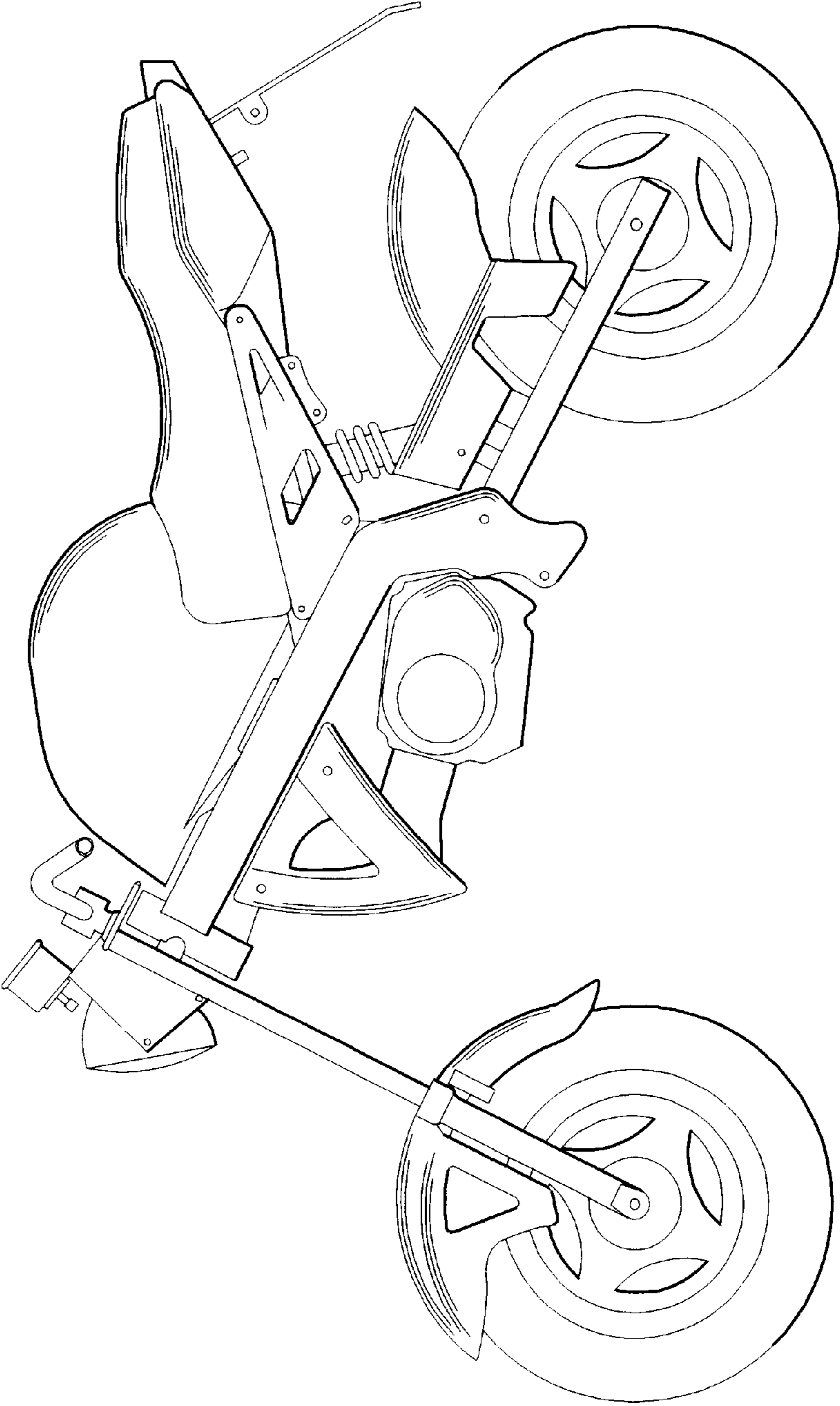

FIG. 2

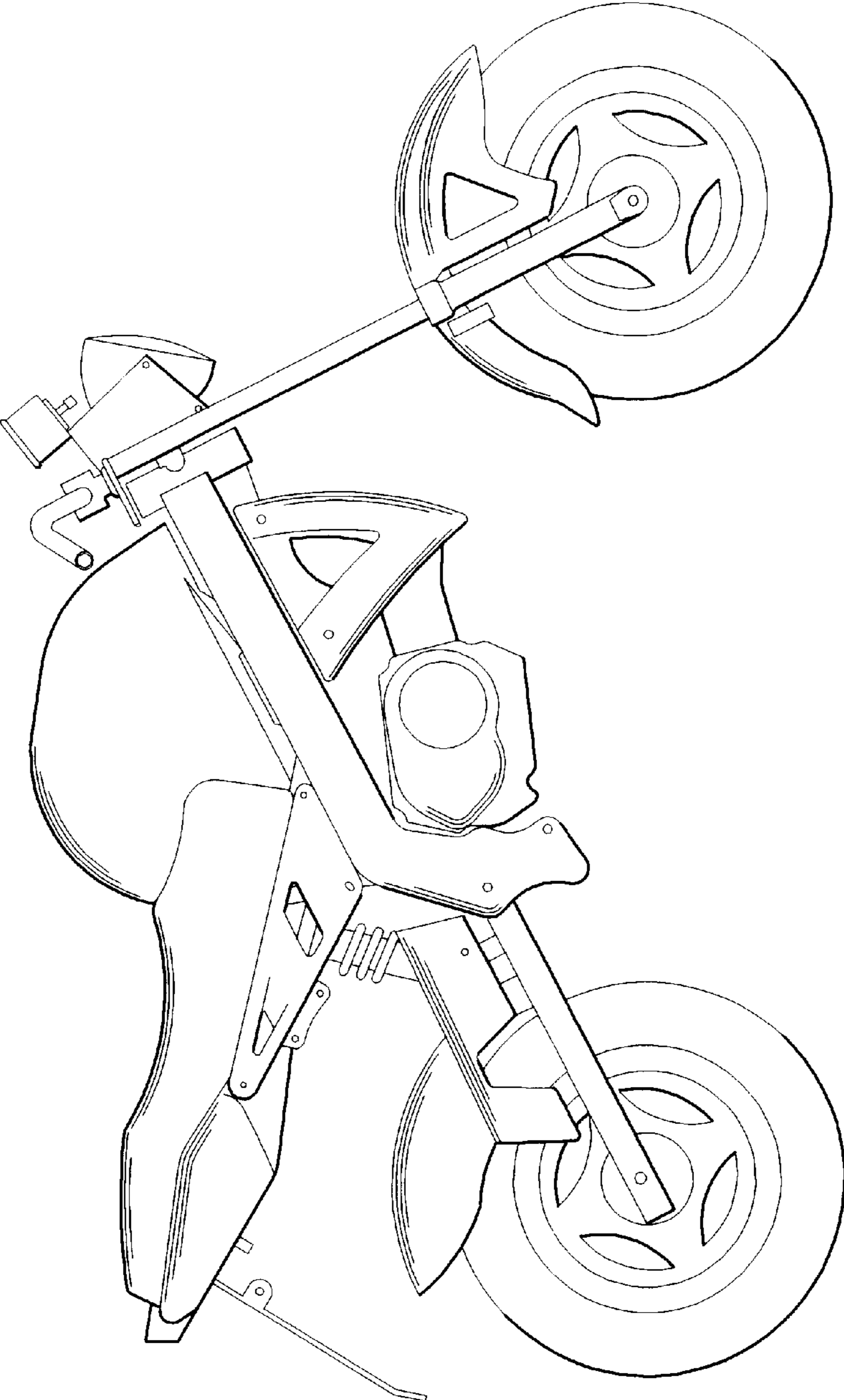

FIG. 3

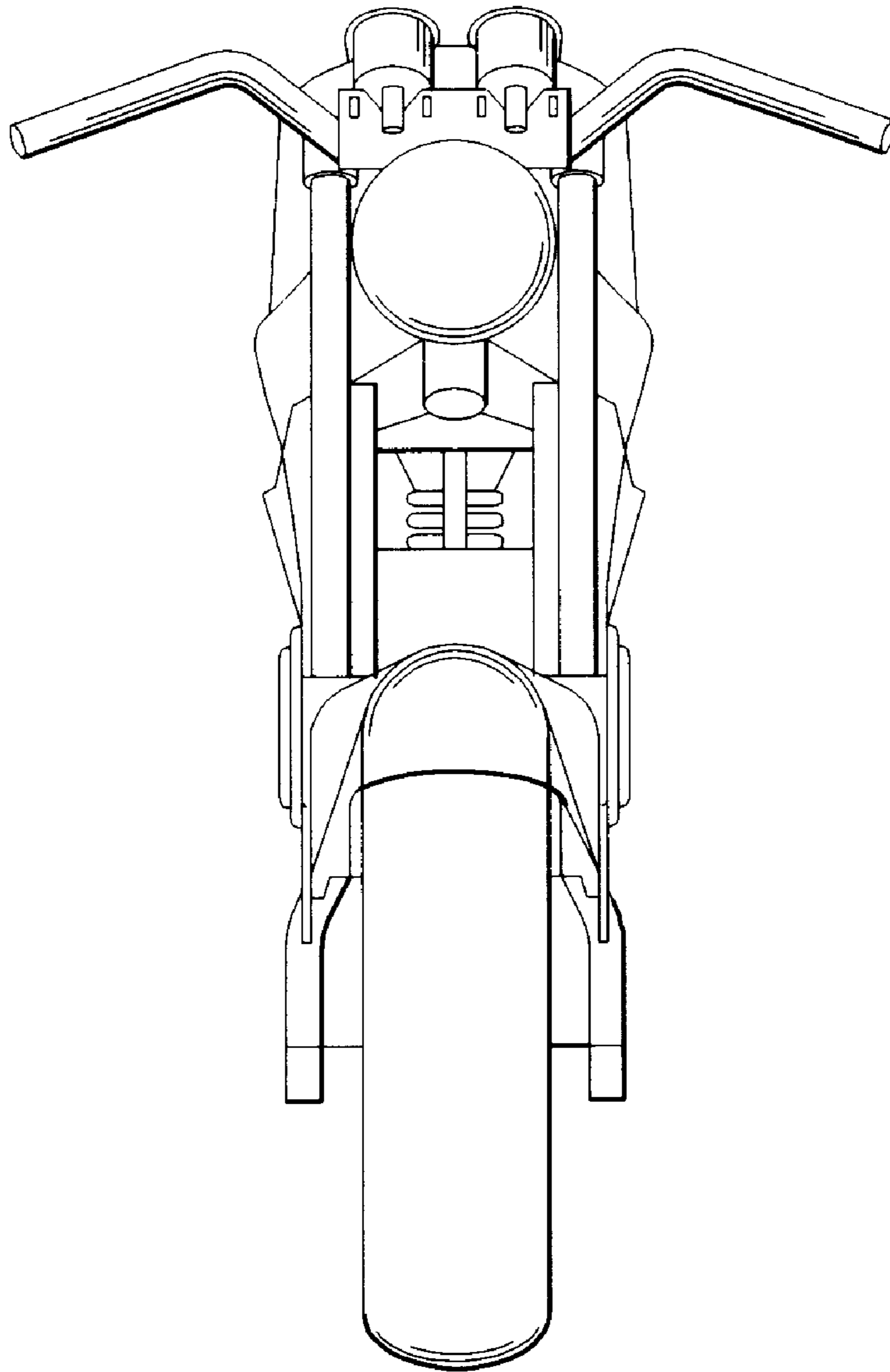

FIG. 4

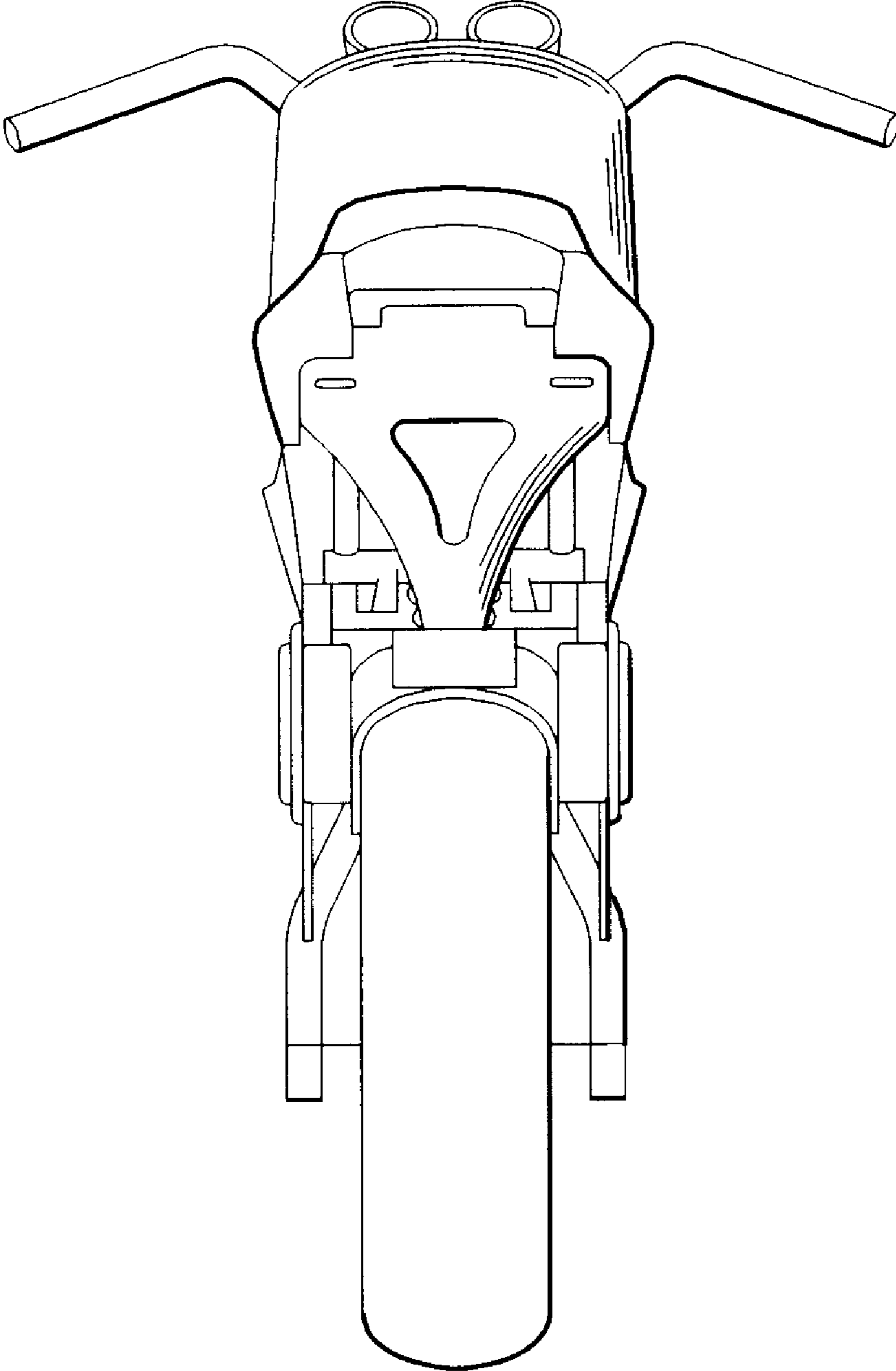

FIG. 5

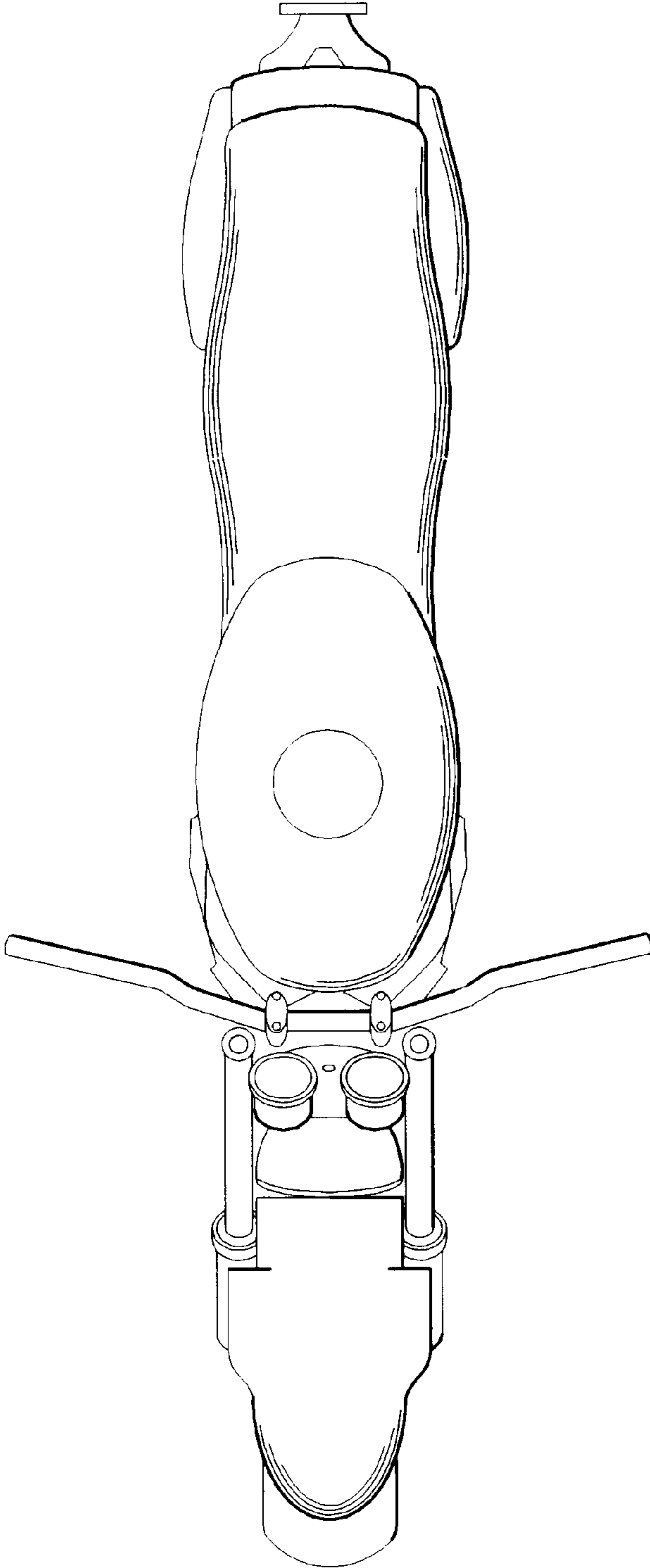

FIG. 6

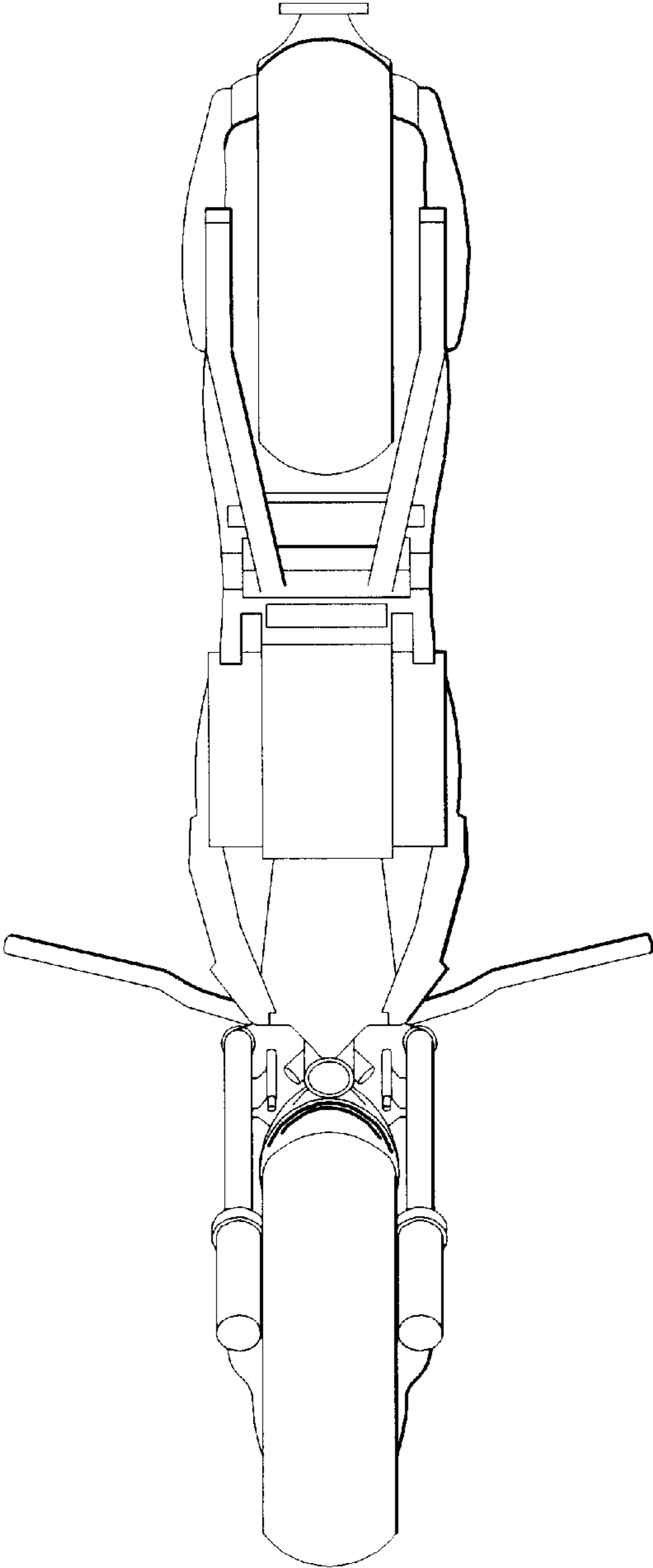

FIG. 7