



US00D513207S

(12) **United States Design Patent** (10) **Patent No.:** **US D513,207 S**
Jones et al. (45) **Date of Patent:** **** Dec. 27, 2005**

(54) **BUCKLE**

D444,117 S 6/2001 Manton
D454,519 S * 3/2002 Gruosi D11/231
D465,759 S 11/2002 Leutz et al.
D476,939 S 7/2003 Francis

(75) Inventors: **James R. Jones**, Town and County,
MO (US); **Michael L. Capriglione**,
Imperial, MO (US); **Howard**
Schroeder, St. Louis, MO (US)

(73) Assignee: **Midwest Motorcycle Supply**
Distributors, Arnold, MO (US)

(**) Term: **14 Years**

(21) Appl. No.: **29/215,330**

(22) Filed: **Oct. 18, 2004**

(51) **LOC (6) Cl.** **02-07**

(52) **U.S. Cl.** **D11/231**

(58) **Field of Search** D11/200, 201,
D11/208-210, 212-218, 220, 230-234,
237, 86-87, 94; 63/15.2, 15; 24/307, 625,
616, 200, 196, 171, 169, 112, 709

(56) **References Cited**

U.S. PATENT DOCUMENTS

1,759,639 A * 5/1930 Belloch 24/709.9
D256,456 S 8/1980 Blanchard
D256,576 S 8/1980 Koch
D256,795 S 9/1980 Blanchard
D256,910 S 9/1980 Patch
D267,563 S 1/1983 Hayashi
D277,052 S * 1/1985 Baron D11/231
D286,869 S 11/1986 Hedlund
D432,482 S 10/2000 Hodges

OTHER PUBLICATIONS

Wheel With "Retro Cross" Design, Bourget Bike Works,
circa 2002.

Three-spoke wheel design by Ego Tripp Wheels, circa 2002.

Four-spoke wheel design by Ego Tripp Wheels, circa 2002.

* cited by examiner

Primary Examiner—Ralf Seifert

(74) *Attorney, Agent, or Firm*—Thompson Coburn LLP

(57) **CLAIM**

The ornamental design for a buckle, as shown and described.

DESCRIPTION

FIG. 1 is a perspective view of a buckle of the present
invention showing our new design;

FIG. 2 is a top plan view of the buckle of FIG. 1;

FIG. 3 is a right side elevational view of the buckle of FIG.
1, the left side elevational view being a mirror image
thereof; and,

FIG. 4 is a front elevational view of the buckle of FIG. 1.
Broken lines shown in the drawings are used to illustrate the
environment and the boundaries of the claimed design, but
form no part of the claimed design. The bottom and rear
views are unornamental and form no part of the claimed
design.

1 Claim, 2 Drawing Sheets

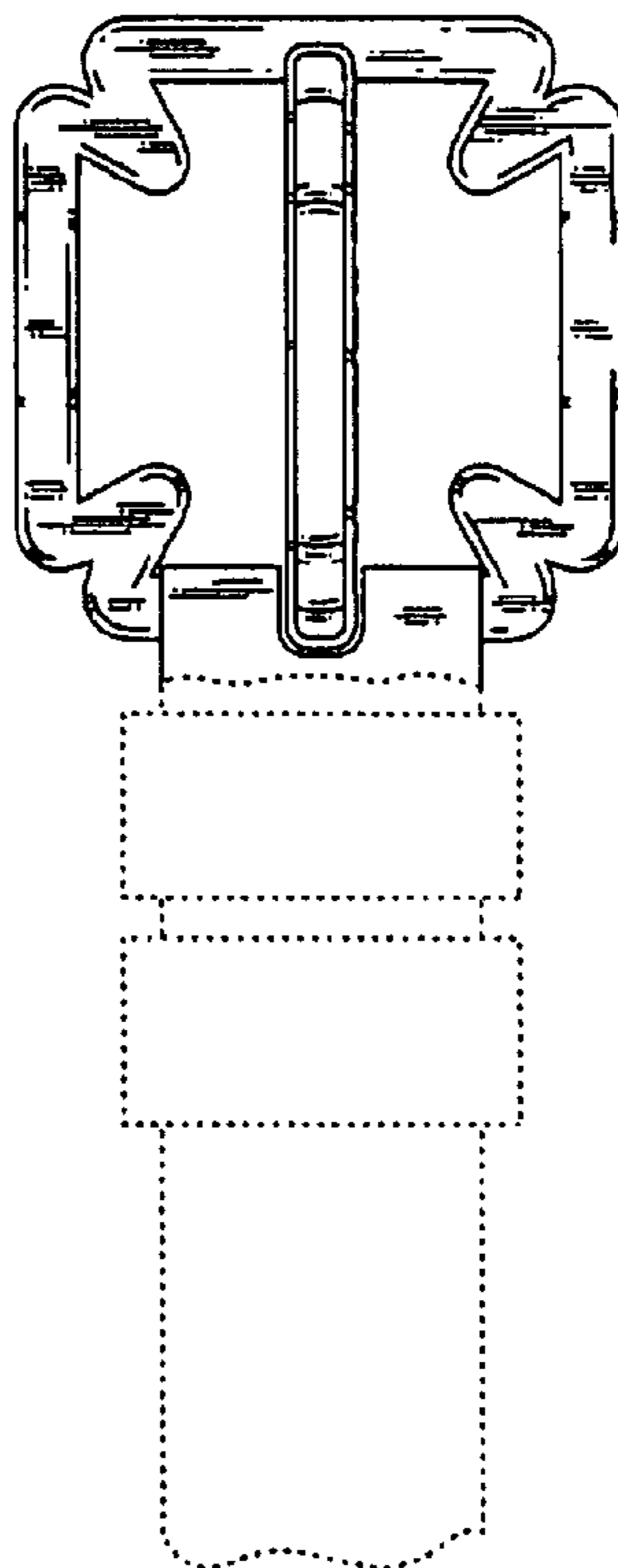

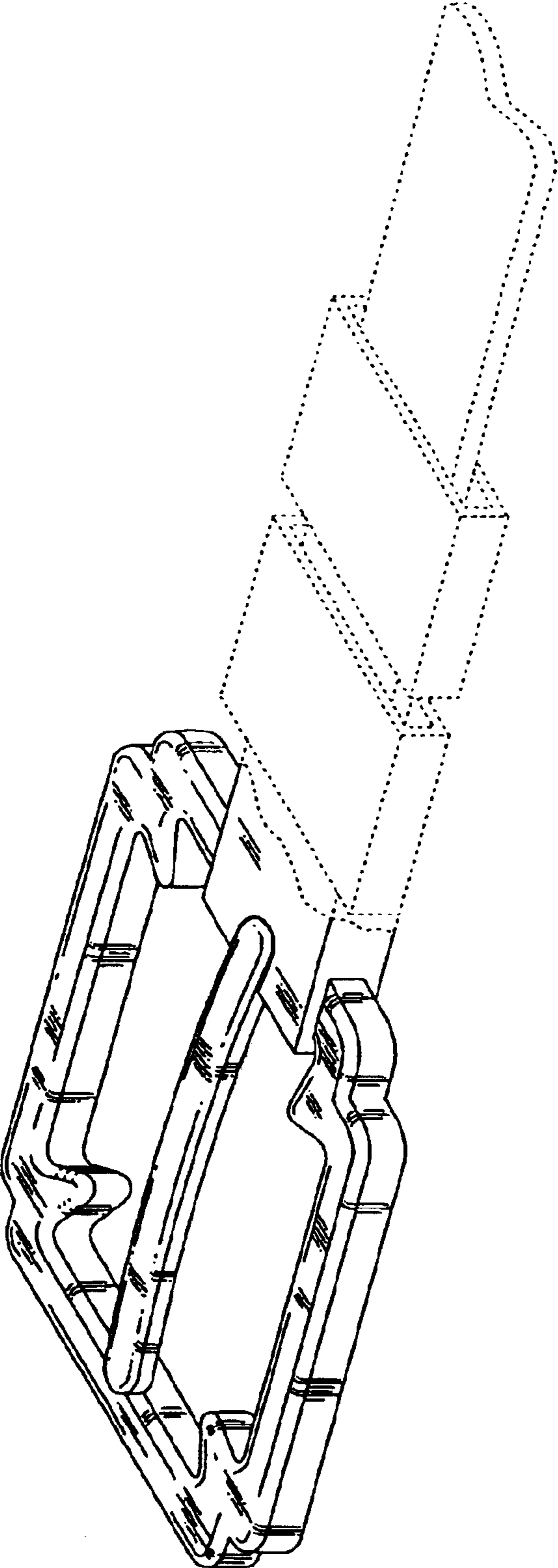

Figure 1

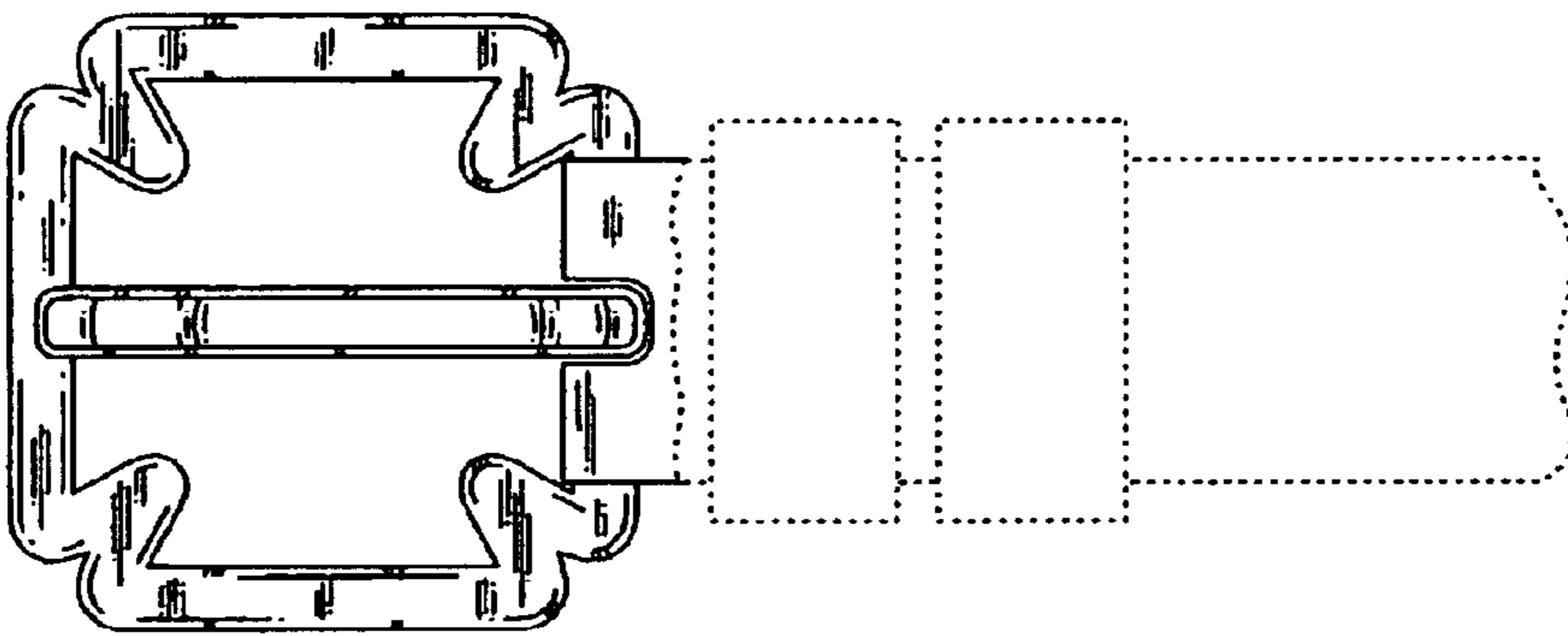

Figure 2

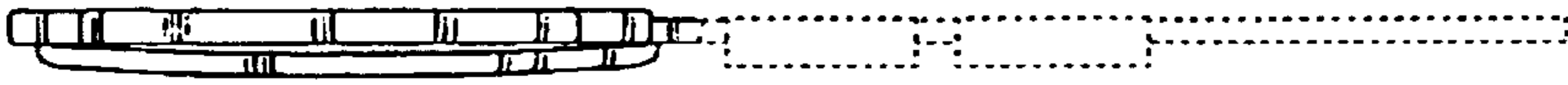

Figure 3



Figure 4