

US00D513073S

(12) **United States Design Patent**  
**Hidalgo**

(10) **Patent No.:** **US D513,073 S**

(45) **Date of Patent:** **\*\* Dec. 20, 2005**

(54) **CEILING FAN HOUSING**

(75) **Inventor:** **Rolando Hidalgo**, Orange, CA (US)

(73) **Assignee:** **Minka Lighting, Inc.**, Corona, CA (US)

(\*\*) **Term:** **14 Years**

(21) **Appl. No.:** **29/206,346**

(22) **Filed:** **May 27, 2004**

(51) **LOC (6) Cl.** ..... **23-04**

(52) **U.S. Cl.** ..... **D23/411**

(58) **Field of Search** ..... D23/377, 379,  
D23/385, 411; 416/5; 392/364

(56) **References Cited**

**U.S. PATENT DOCUMENTS**

D352,997 S	*	11/1994	DiPasquale	.....	D23/411
D454,630 S	*	3/2002	Hidalgo	.....	D23/377
D480,129 S	*	9/2003	Curtin	.....	D23/377
D480,797 S	*	10/2003	Young	.....	D23/411

**OTHER PUBLICATIONS**

Minka Aire—The Art of Air Management, p. 19, Jan. 1998, Minka Lighting, Inc., USA.  
Minka Aire—The Art of Air Management, p. 31, Jan. 1998, Minka Lighting, Inc., USA.  
Minka Aire 2000; p. 24, Jan. 2000, Minka Lighting, Inc., USA.

Minka Aire 2004; pp. 42–43, Jan. 2004, Minka Lighting, Inc. USA.

\* cited by examiner

*Primary Examiner*—Lisa Lichtenstein

(74) *Attorney, Agent, or Firm*—Baker & McKenzie LLP

(57) **CLAIM**

The ornamental design for the ceiling fan housing, as shown and described.

**DESCRIPTION**

FIG. 1 is a perspective view from below of a ceiling fan housing in accordance with my design, including the environment thereof;

FIG. 2 is an enlarged perspective view from below of the ceiling fan housing in accordance with my design, including the environment thereof;

FIG. 3 is a bottom plan view of ceiling fan housing in accordance with my design, including the environment thereof;

FIG. 4 is a top plan view of the ceiling fan housing in accordance with my design, including the environment thereof; and,

FIG. 5 is a side elevation view of the ceiling fan housing in accordance with my design, the opposite side being a mirror image of that shown including the environment thereof.

The broken lines showing environmental structure are for illustrative purposes and form no part of the claimed design. In FIG. 2, the fan blades are shown broken away to indicate indeterminate length.

**1 Claim, 5 Drawing Sheets**

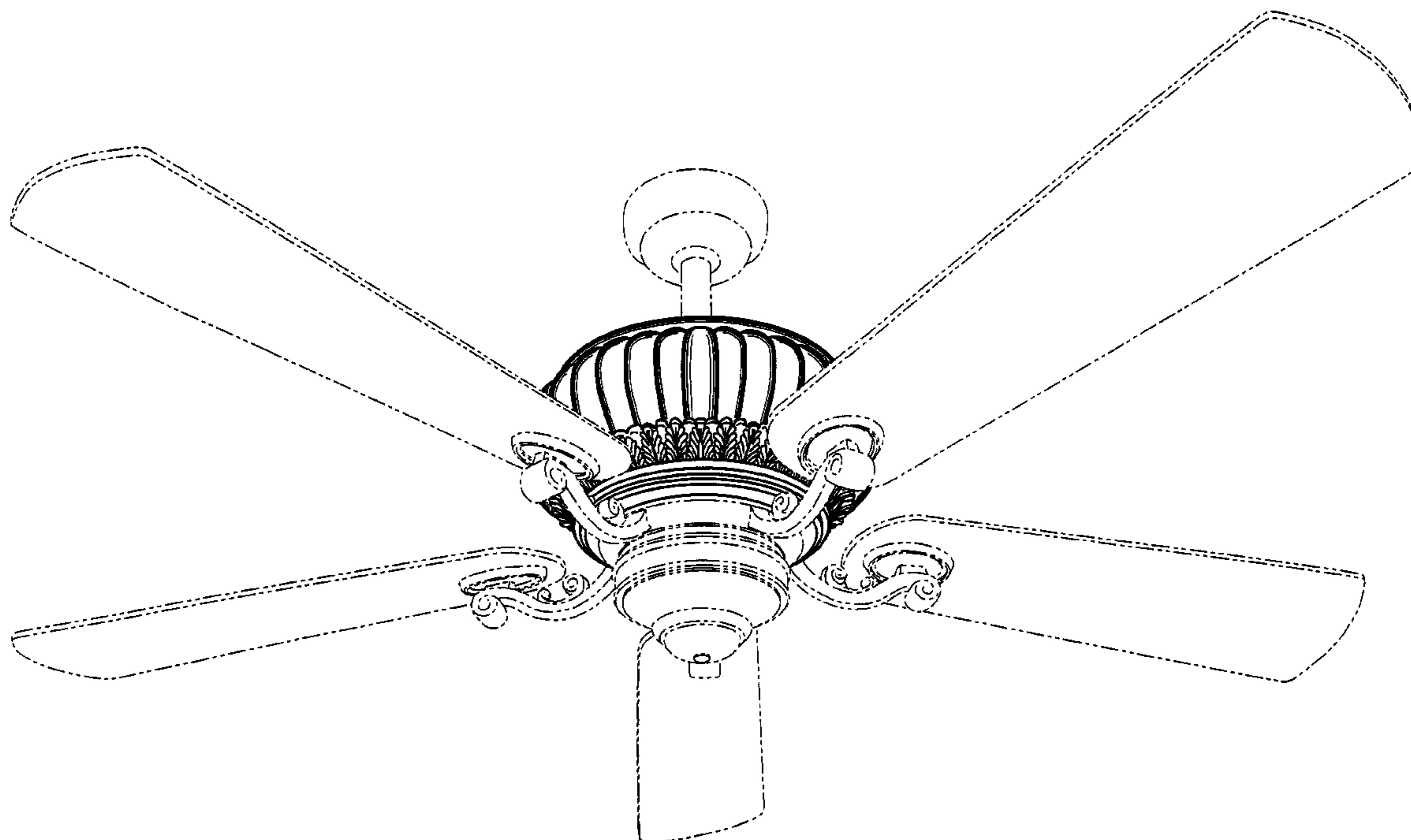

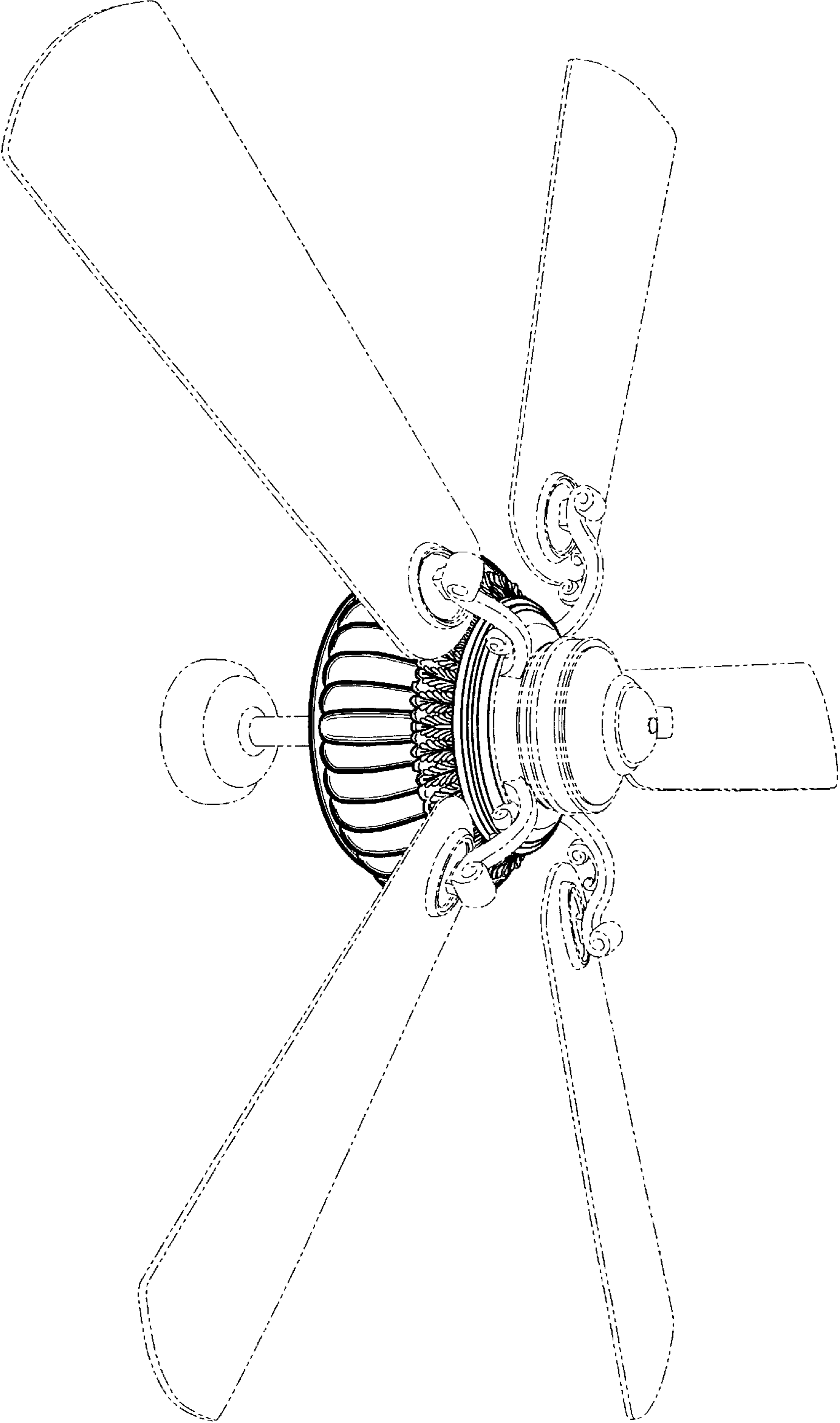

**Fig.1**

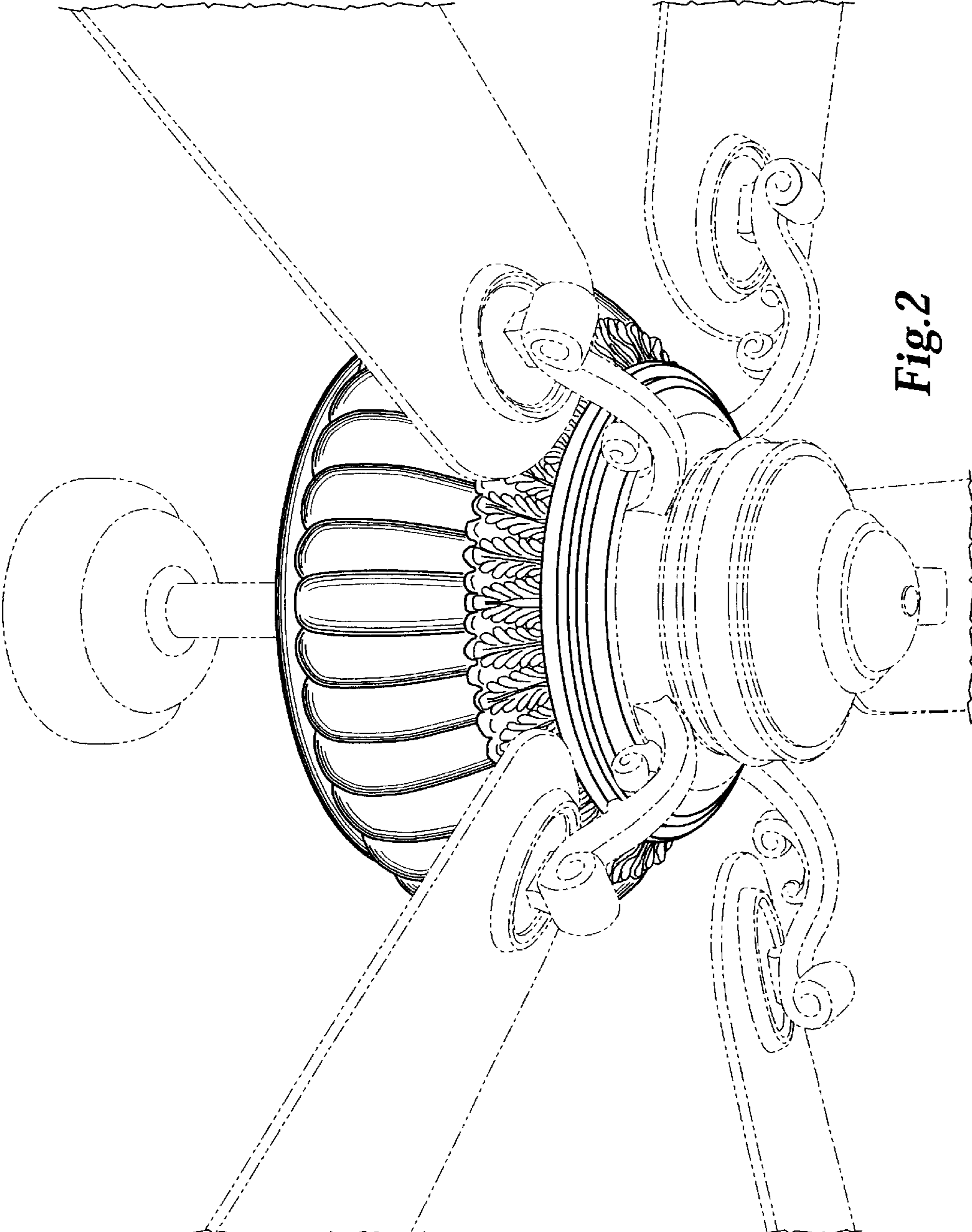
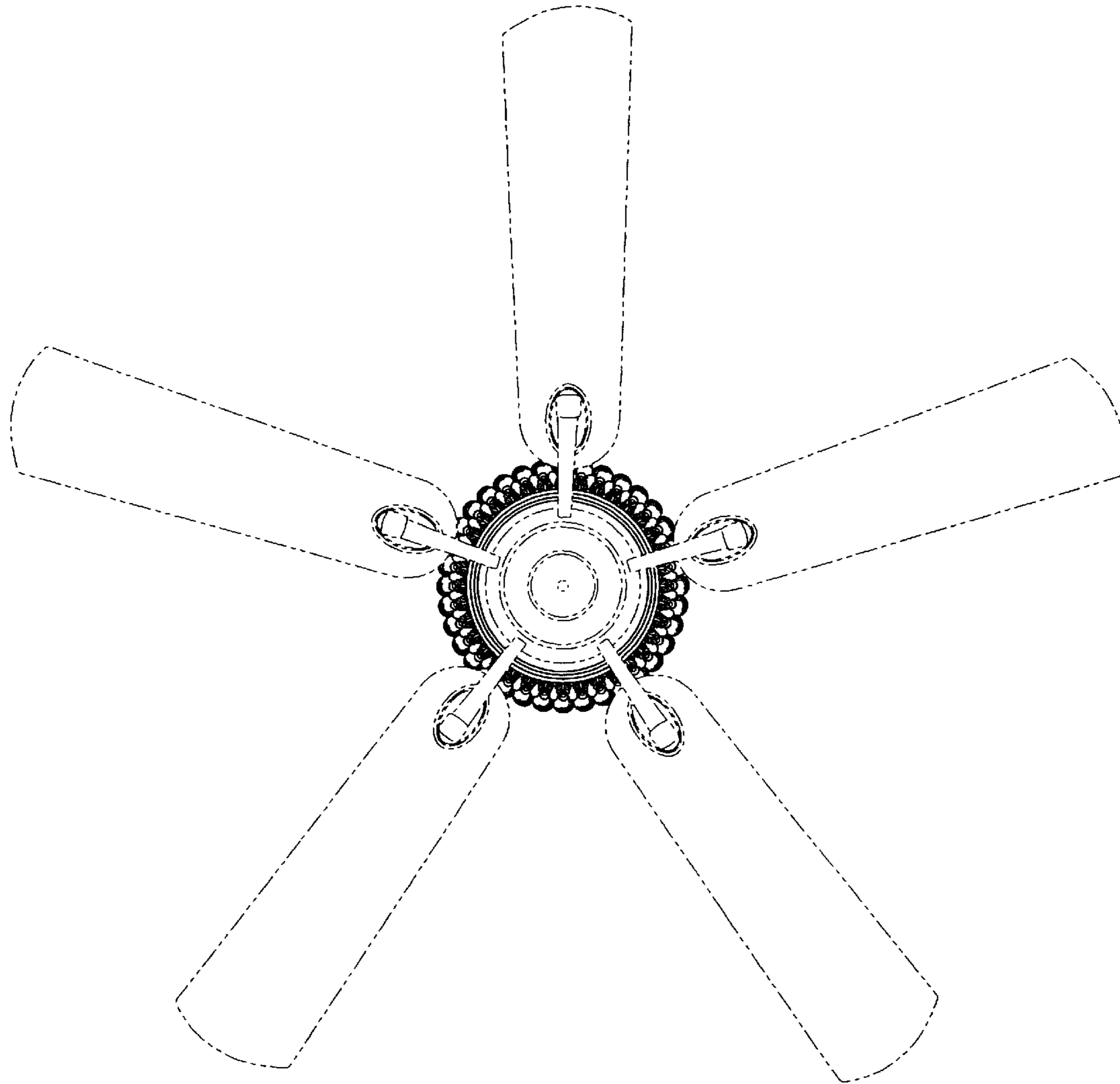
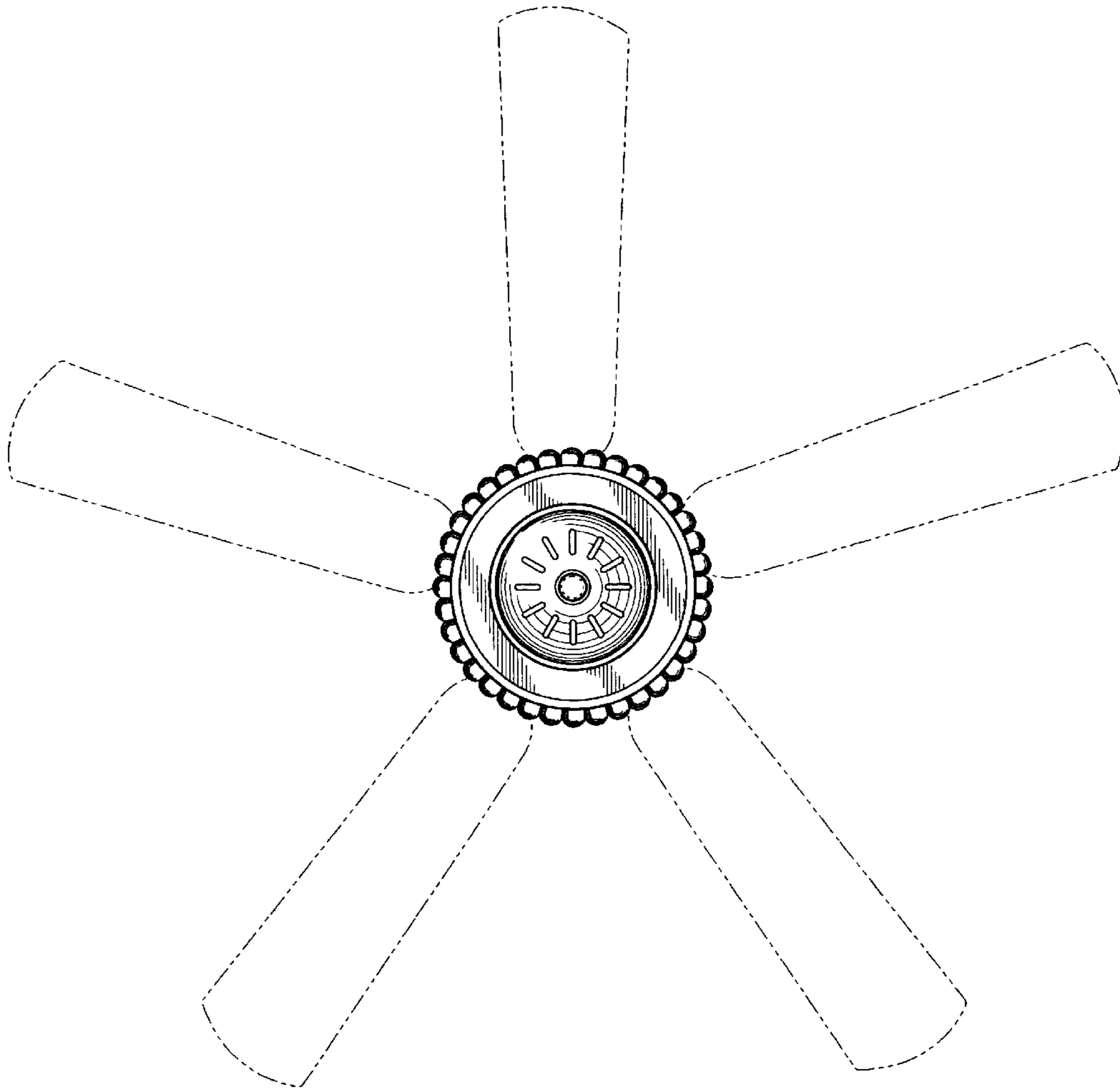

Fig. 2



**Fig. 3**



*Fig.4*

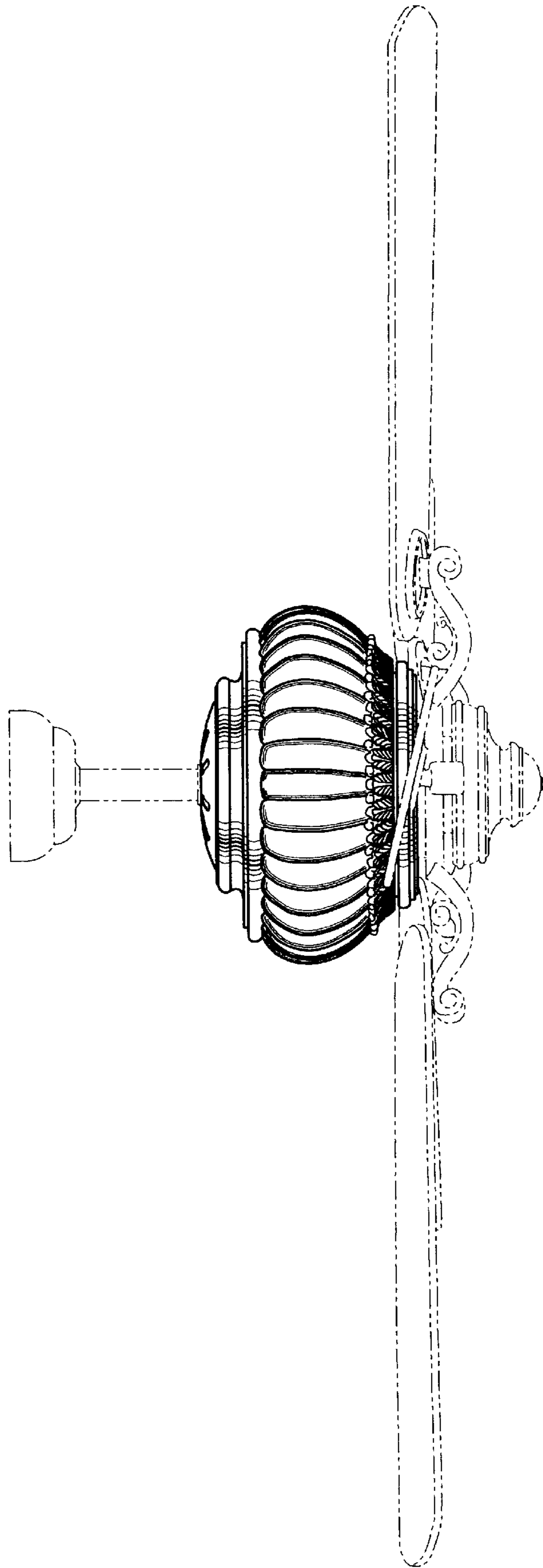

*Fig. 5*