



US00D513053S

(12) **United States Design Patent**
Bourget

(10) **Patent No.:** **US D513,053 S**
(45) **Date of Patent:** **** Dec. 20, 2005**

(54) **ALFRESCO TACTILE BRIDGE STUDDED**

5,334,098 A * 8/1994 Pope et al. 472/116

(75) Inventor: **Christelle Bourget**, Bressuire (FR)

* cited by examiner

(73) Assignee: **WESCO Company, S.A.**, Cerizay (FR)

Primary Examiner—Mitchell Siegel

(74) *Attorney, Agent, or Firm*—Horst M. Kasper

(**) Term: **14 Years**

(57) **CLAIM**

(21) Appl. No.: **29/208,427**

The ornamental design for alfresco tactile bridge studded, as shown and described.

(22) Filed: **Jun. 29, 2004**

(30) **Foreign Application Priority Data**

DESCRIPTION

Dec. 29, 2003 (EM) 000184825-0012

FIG. 1 is a front elevational view of alfresco tactile bridge studded

(51) **LOC (6) Cl.** **21-03**

FIG. 2 is a top plan view thereof;

(52) **U.S. Cl.** **D21/814**

FIG. 3 is a right side elevational view thereof; the undisclosed left side being a identical;

(58) **Field of Search** D21/811, 814,
D21/818-827, 499, 501; 482/35, 36; 472/136

FIG. 4 is a bottom elevational view thereof; and,

FIG. 5 is a front and side perspective view of alfresco tactile bridge studded thereof.

(56) **References Cited**

U.S. PATENT DOCUMENTS

D340,274 S * 10/1993 Gleeson et al. D21/826

1 Claim, 3 Drawing Sheets



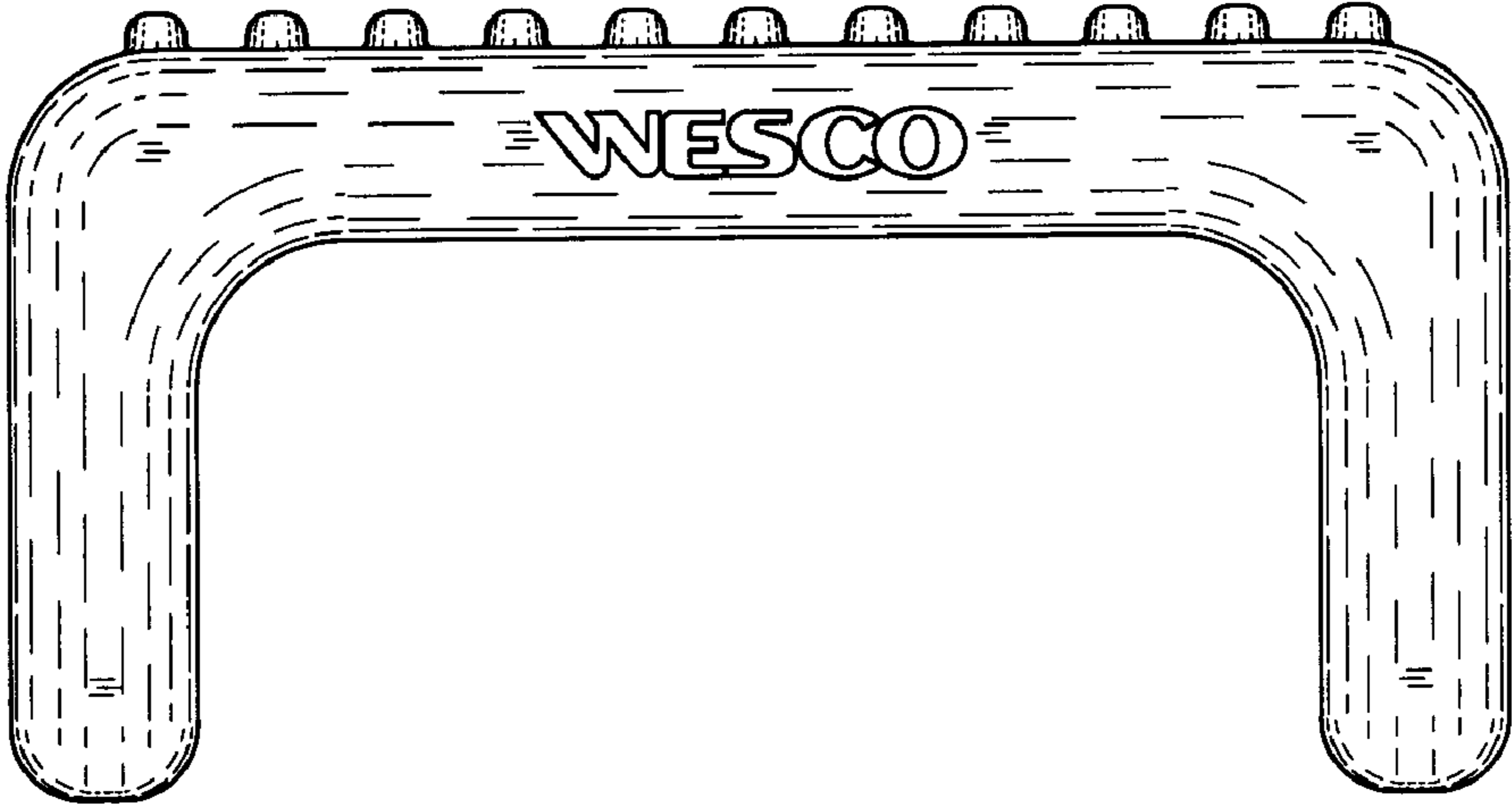

Fig. 1

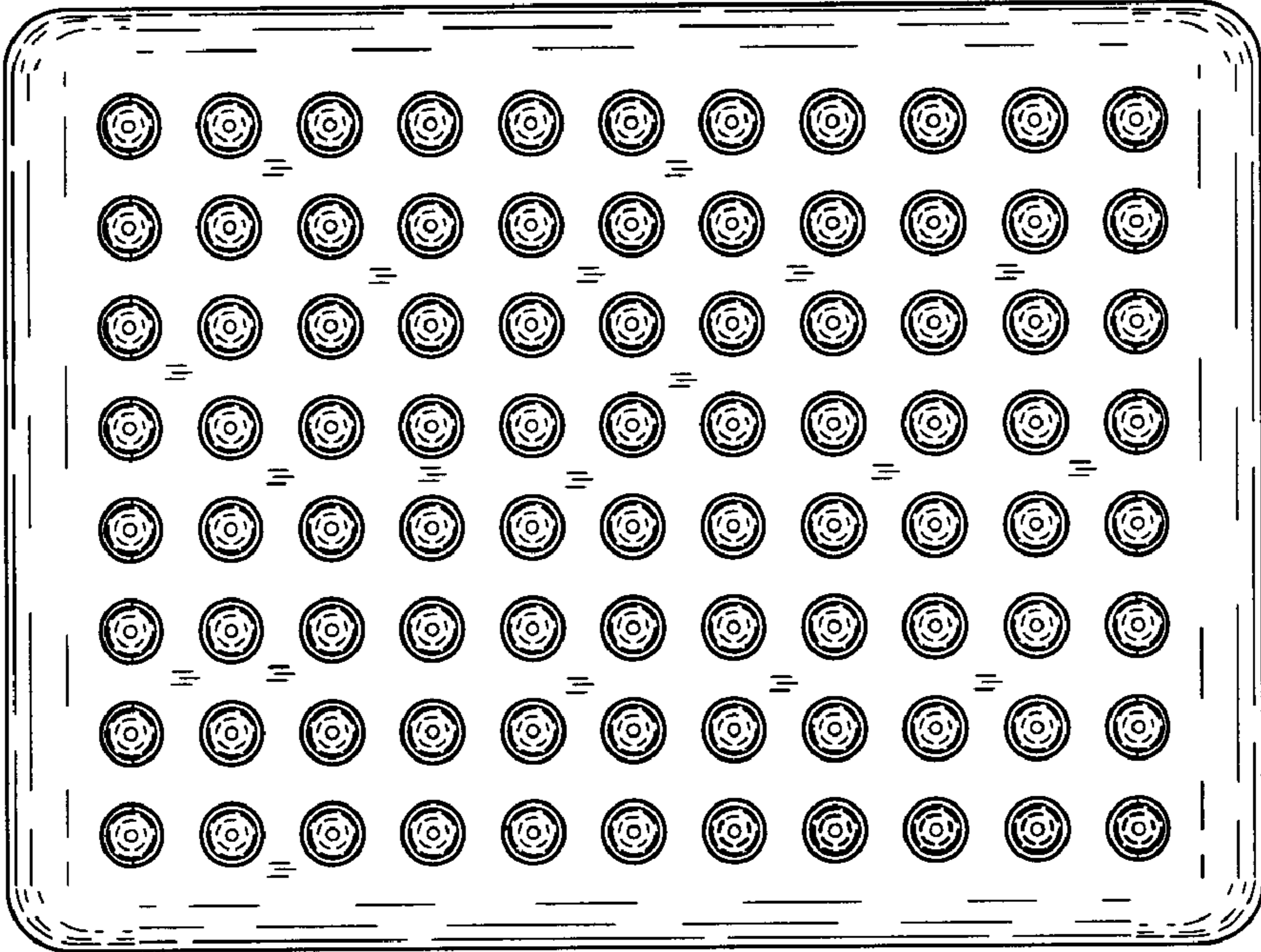

Fig. 2

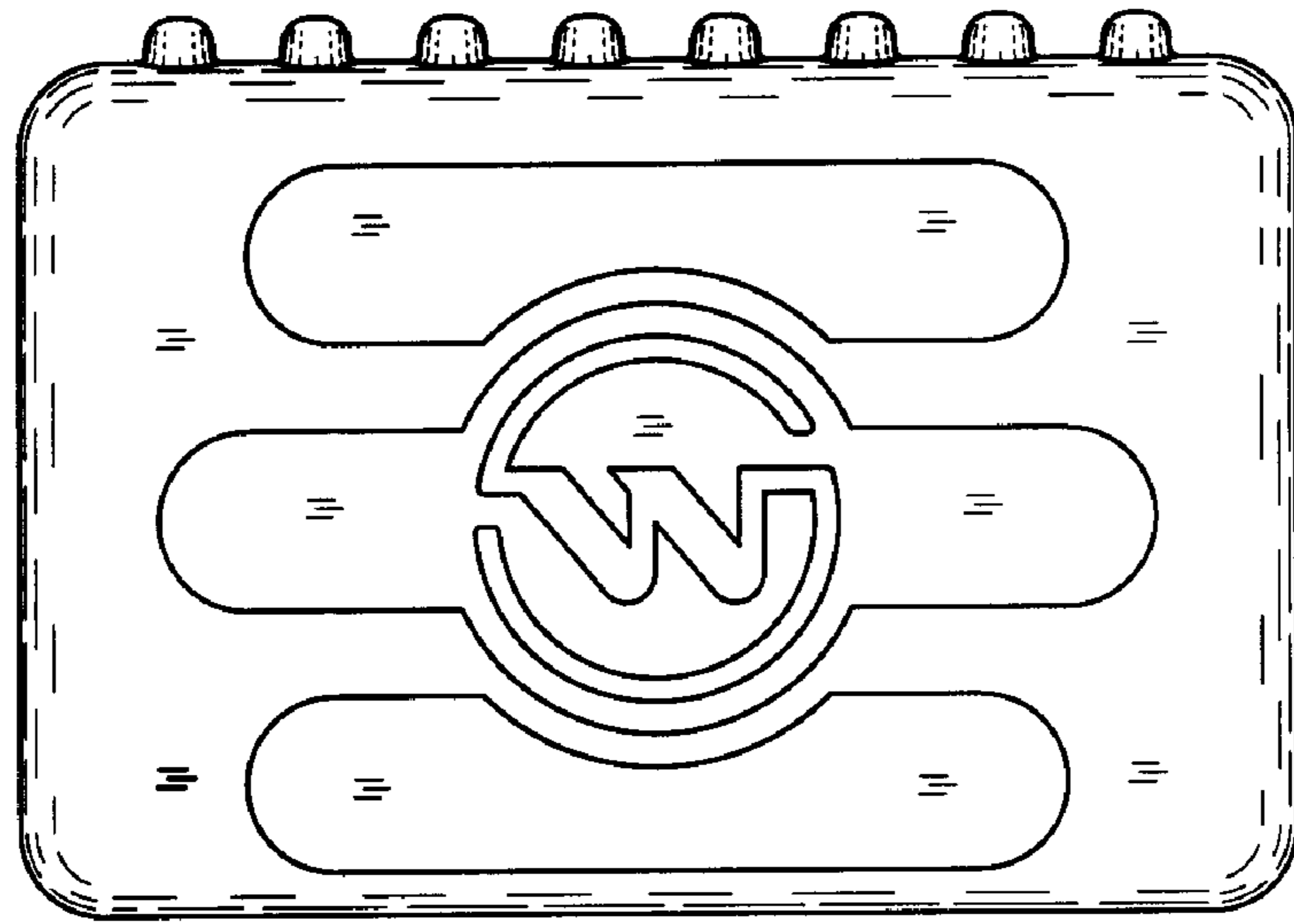

Fig. 3

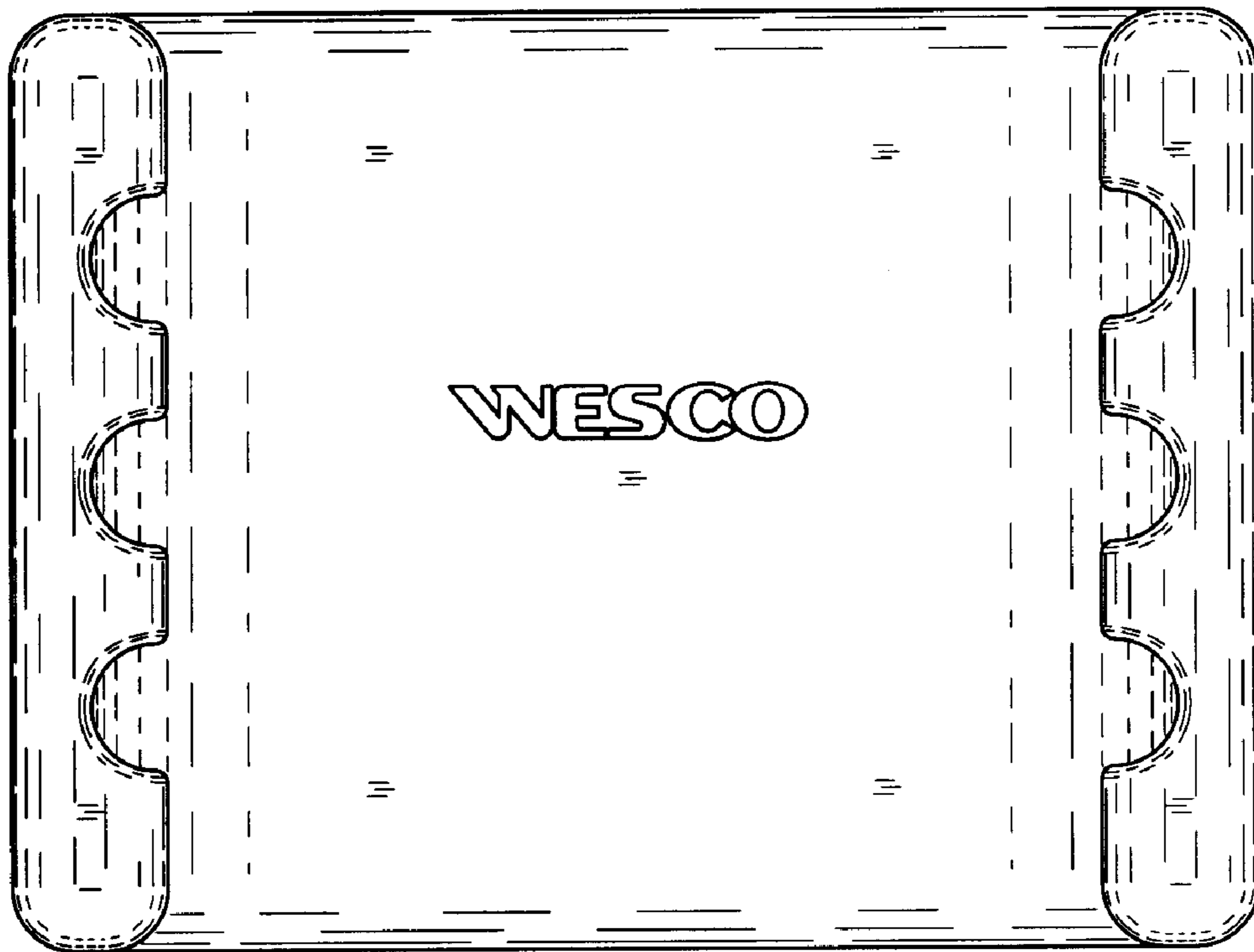

Fig. 4

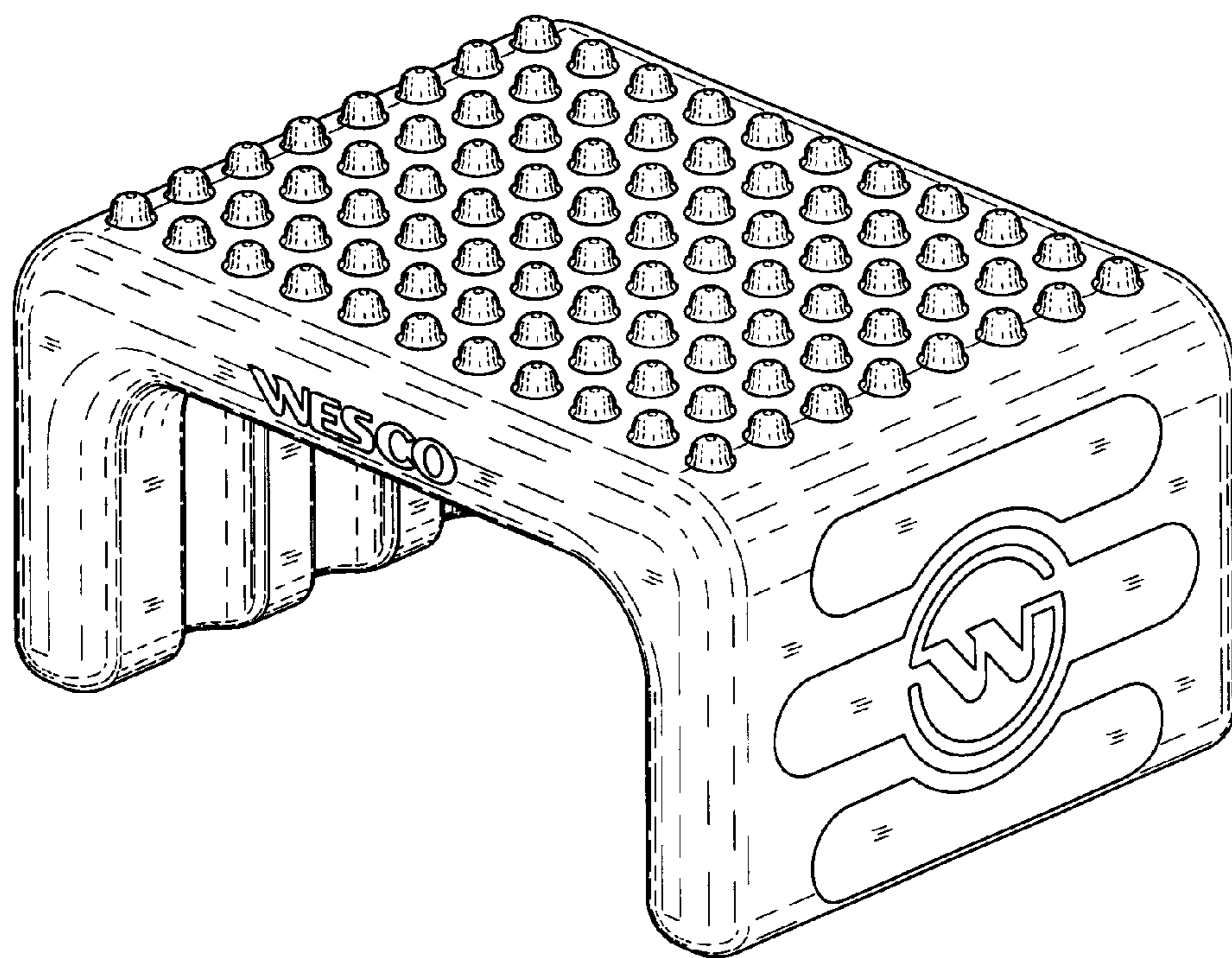

Fig. 5