

US00D513012S

(12) **United States Design Patent** (10) **Patent No.:** **US D513,012 S**  
**Strandell et al.** (45) **Date of Patent:** **\*\* Dec. 20, 2005**

(54) **COVER FOR AN ENGINE**

(75) Inventors: **Tim Strandell**, Racine, WI (US); **Mike Phillips**, Milwaukee, WI (US); **Mark Brenneman**, Burlington, WI (US)

(73) Assignee: **Briggs & Stratton Corporation**, Wauwatosa, WI (US)

(\*\*) Term: **14 Years**

(21) Appl. No.: **29/208,525**

(22) Filed: **Jun. 30, 2004**

(51) **LOC (6) Cl.** ..... **15-01**

(52) **U.S. Cl.** ..... **D15/5**

(58) **Field of Search** ..... D15/1, 3, 5; 123/195.3, 123/198 E, 41, 50, 50 B, 50 R, 65 R, 70 R

(56) **References Cited**

**U.S. PATENT DOCUMENTS**

D46,875 S	*	1/1915	Neeley et al.	.....	D26/84
D198,043 S		4/1964	Stevens		
4,233,043 A		11/1980	Catterson		
D293,114 S	*	12/1987	Brogdon	.....	D15/1
D294,832 S	*	3/1988	Itou et al.	.....	D15/1
D307,147 S	*	4/1990	Sasaki et al.	.....	D15/1
D307,148 S	*	4/1990	Mikado	.....	D15/1
5,197,426 A		3/1993	Frangesch et al.		
5,199,389 A		4/1993	Wold et al.		
5,251,428 A		10/1993	Gay		
D352,043 S		11/1994	Davies, III		
D353,381 S	*	12/1994	Yoshida et al.	.....	D15/1
D361,771 S		8/1995	Ledingham		
D367,070 S	*	2/1996	Maeda et al.	.....	D15/1
D396,045 S	*	7/1998	Neeley	.....	D15/1
D396,476 S	*	7/1998	Shimizu	.....	D15/1
D397,342 S	*	8/1998	Shimizu	.....	D15/5
D474,783 S	*	5/2003	Momoi	.....	D15/1
D488,167 S	*	4/2004	Momoi	.....	D15/1
D497,368 S	*	10/2004	Csiki	.....	D15/5

**OTHER PUBLICATIONS**

Briggs & Stratton Corporation; 04 Engine Guide; brochure; at least as early as Mar. 1, 2004; pp. 5–58 (excluding front & back covers); Wauwatosa, Wisconsin.

KAWASAKI, Four-Cycle Engines, Kawasaki FJ180V, website, [http://www.kawpowr.com/4cycle/fj180v\\_specs.html](http://www.kawpowr.com/4cycle/fj180v_specs.html), 1 page, Feb. 2, 2005.

KAWASAKI, Four-Cycle Engines, Kawasaki FC290v, website, [http://www.kawpowr.com/4cycle/fc290v\\_specs.html](http://www.kawpowr.com/4cycle/fc290v_specs.html), 1 page, Feb. 2, 2005.

KAWASAKI, Four-Cycle Engines, Kawasaki FH721D, website, [http://www.kawpowr.com/4cycle/fh721d\\_specs.html](http://www.kawpowr.com/4cycle/fh721d_specs.html), 1 page, Feb. 2, 2005.

KAWASAKI, Four-Cycle Engines Kawasaki FH601D, website, [http://www.kawpowr.com/4cycle/fh601d\\_specs.html](http://www.kawpowr.com/4cycle/fh601d_specs.html), 1 page, Feb. 2, 2005.

KAWASAKI, Four-Cycle Engines Kawasaki EH601V . . . Feb 2, 2005.

KAWASAKI, Four-Cycle Engines, Kawasaki FH500V, website, [http://www.kawpowr.com/4cycle/fh500V\\_specs.html](http://www.kawpowr.com/4cycle/fh500V_specs.html), 1 page, Feb. 2, 2005.

(Continued)

*Primary Examiner*—Joel A. Sincavage

*Assistant Examiner*—Maurice Stevens

(74) *Attorney, Agent, or Firm*—Michael Best & Friedrich, LLP

(57) **CLAIM**

The ornamental design for a cover for an engine, as shown and described.

**DESCRIPTION**

FIG. 1 is a perspective view of a cover for an engine according to one embodiment of the invention;

FIG. 2 is a top view of the cover of FIG. 1;

FIG. 3 is a bottom view of the cover of FIG. 1;

FIG. 4 is a front view of the cover of FIG. 1;

FIG. 5 is a rear view of the cover of FIG. 1;

FIG. 6 is a left side view of the cover of FIG. 1; and,

FIG. 7 is a right side view of the cover of FIG. 1.

The broken line showing of the environment is for illustrative purposes only and forms no part of the claimed design.

**1 Claim, 7 Drawing Sheets**

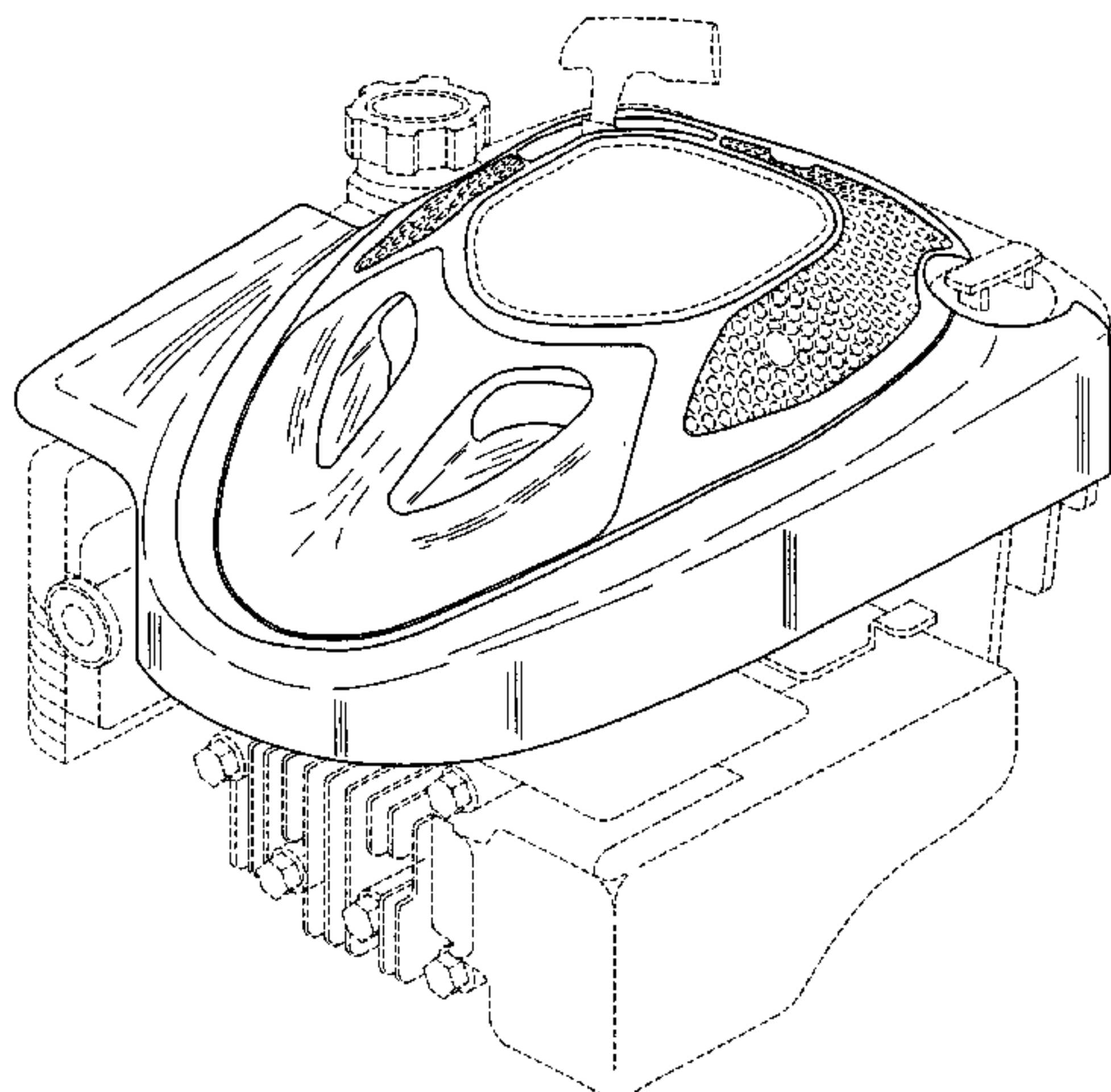

OTHER PUBLICATIONS

KAWASAKI, Four-Cycle Engines, Kawasaki FC150V, website, [http://www.kawpowr.com/4cycle/fc150v\\_specs.html](http://www.kawpowr.com/4cycle/fc150v_specs.html), 1 page, Feb. 2, 2005.

KAWASAKI, Four-Cycle Engines, Kawasaki FH721V, website, [http://www.kawpowr.com/4cycle/fh721v\\_specs.html](http://www.kawpowr.com/4cycle/fh721v_specs.html), 1 page, Feb. 2, 2005.

Tecumseh Power Company; Walk-Behind Engines & Transmissions Horsepower Range: 3.5-7.0, website <http://www.tecumsehpower.com/Products/WalkBehind/index.php>, 1 page, Feb. 2, 2005.

Kohler Co. Engine Division; Kohler Engines Born to Run Owner's Manual, Command 11-16 HP Vertical Crankshaft; Cover Sheet, Revised Sep. 1999, Kohler Co. Engine Division, Kohler, Wisconsin, USA.

Kohler Co. Engine Division; Kohler Engines Born to Run Owner's Manual, Command 18-26 HP Horizontal Crankshaft; Cover Sheet, Revised May 1999, Kohler Co. Engine Division, Kohler, Wisconsin, USA.

Kohler Co. Engine Division; Kohler Engines Born to Run Owner's Manual, Command 11-15 HP Horizontal Crankshaft; Cover Sheet, Revised Apr. 1999, Kohler Co. Engine Division, Kohler, Wisconsin, USA.

Kohler Co. Engine Division; Kohler Engines Born to Run Owner's Manual, Magnum 8,12,16 HP Horizontal Crankshaft; Cover Sheet, Revised Dec. 2001, Kohler Co. Engine Division, Kohler, Wisconsin, USA.

Kohler Co. Engine Division; Kohler Engines Service Manual, Courage Series SV470-600 Vertical Crankshaft; website [http://www.kohlerengines.com/onlinecatalog/detail.jsp?prod\\_num=Hydro+13](http://www.kohlerengines.com/onlinecatalog/detail.jsp?prod_num=Hydro+13), Cover Sheet, Feb. 2, 2005, Kohler Co. Engine Division, Kohler, Wisconsin, USA.

Kohler Co. Engine Division; Kohler Engines Kohler Triad OHC; website [http://www.kohlerengines.com/onlinecatalog/enginefamily.jsp?engine\\_family\\_name=Triad+OHC](http://www.kohlerengines.com/onlinecatalog/enginefamily.jsp?engine_family_name=Triad+OHC), Cover Sheet Feb. 2, 2005, Kohler Co. Engine Division, Kohler, Wisconsin, USA.

Honda Engines, Honda GC Series Engines, brochure, 2003, 10 pages, American Honda Motor Co, Inc.

\* cited by examiner

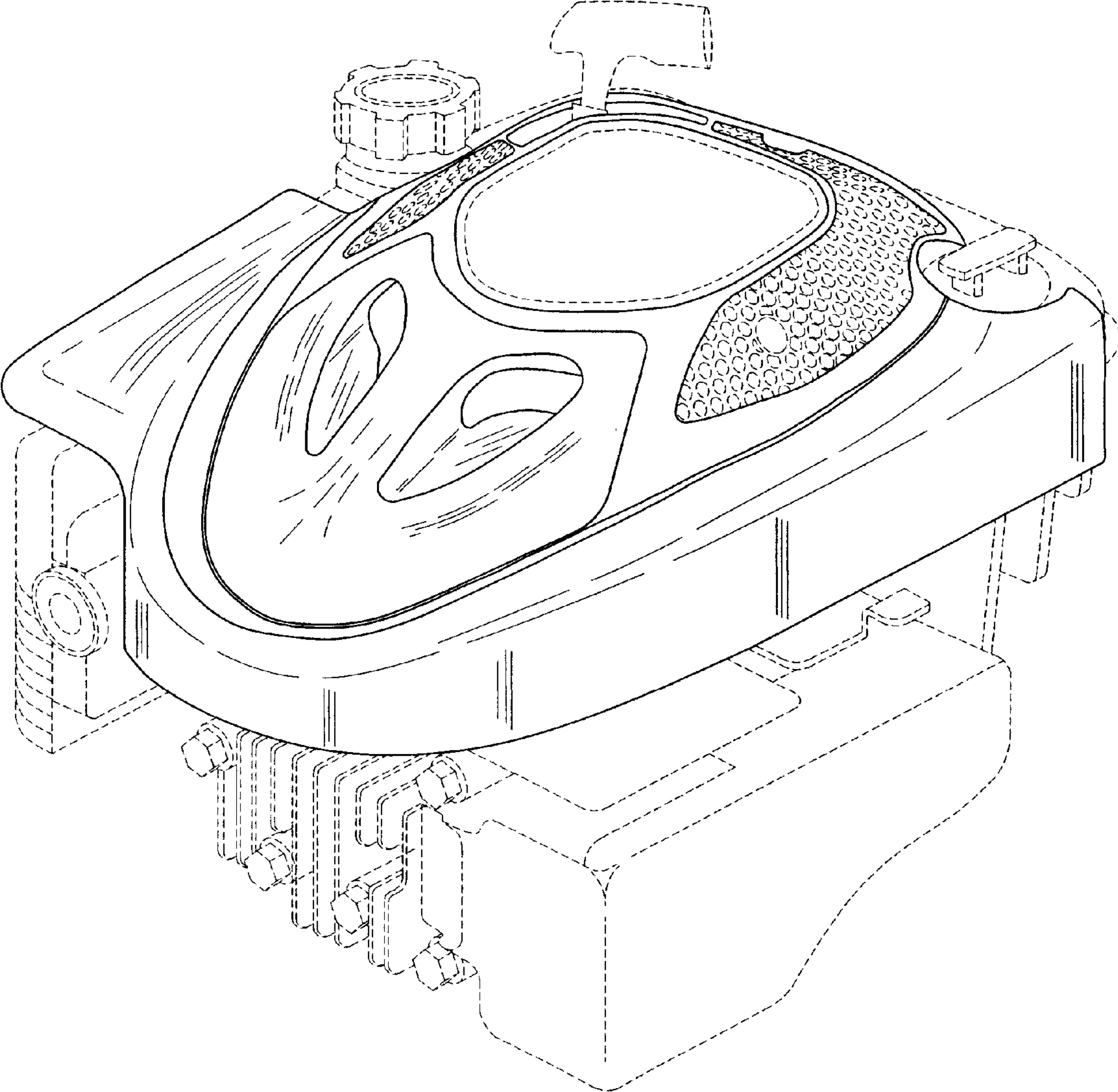

FIG. 1



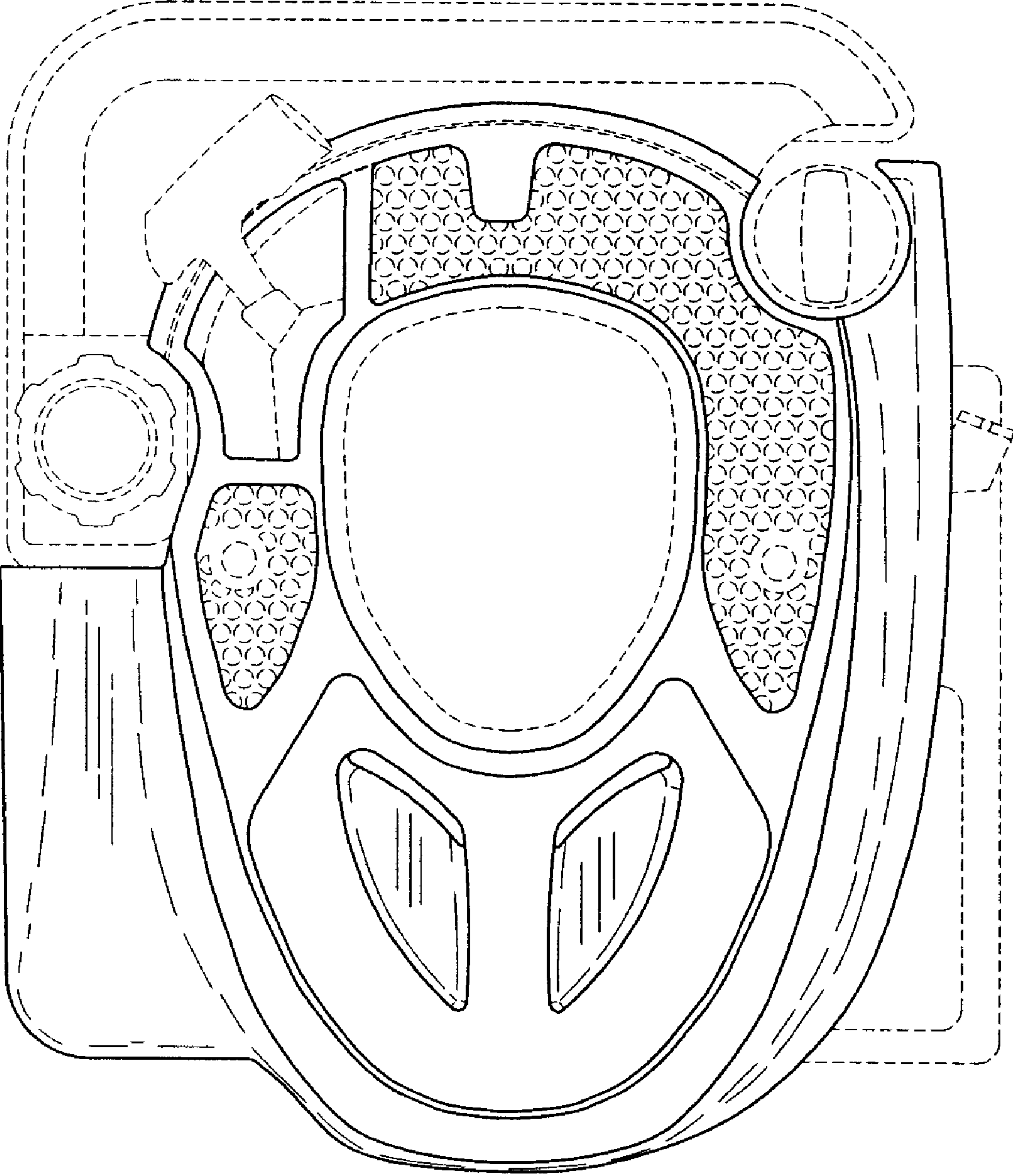

FIG. 2

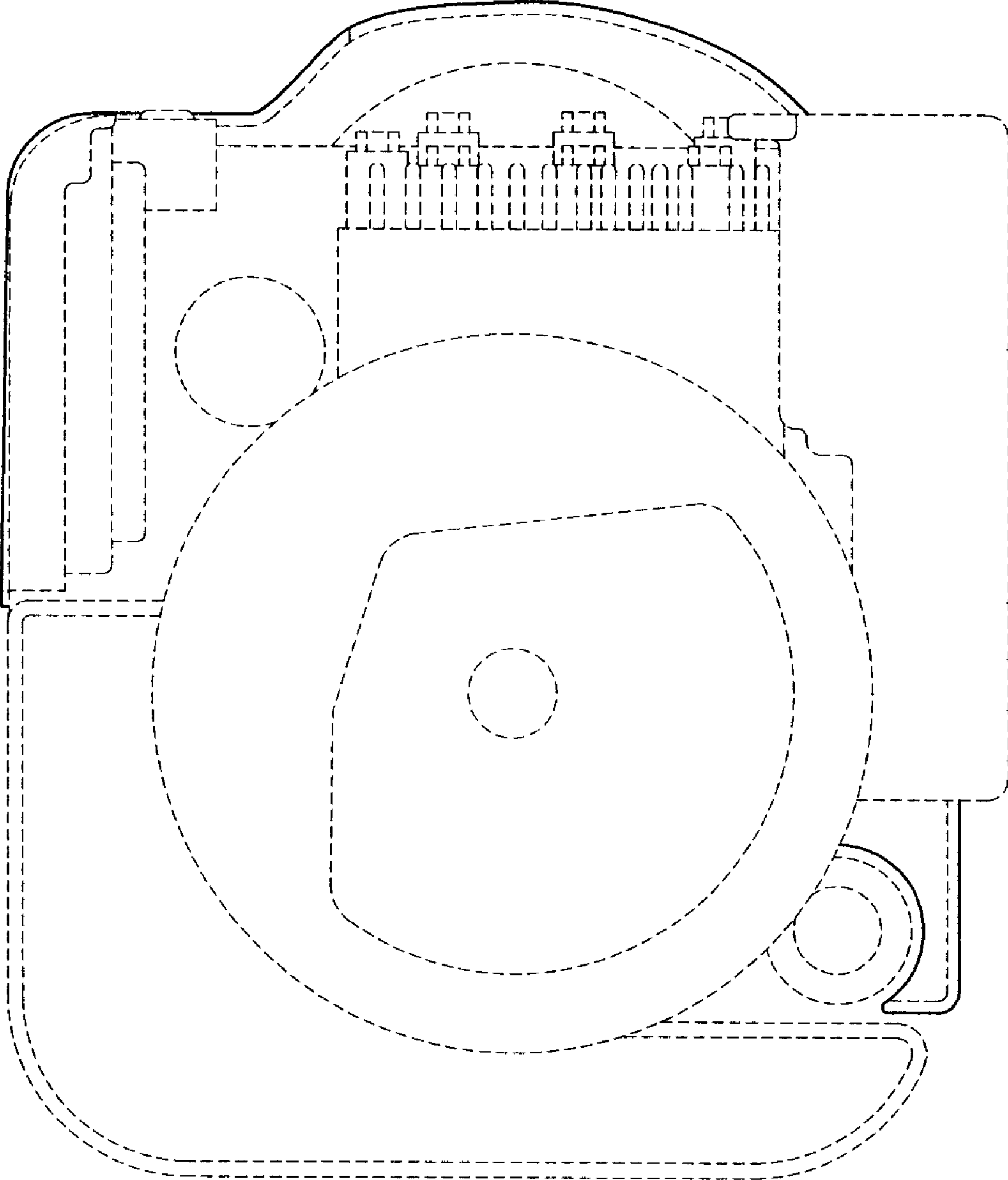

FIG. 3

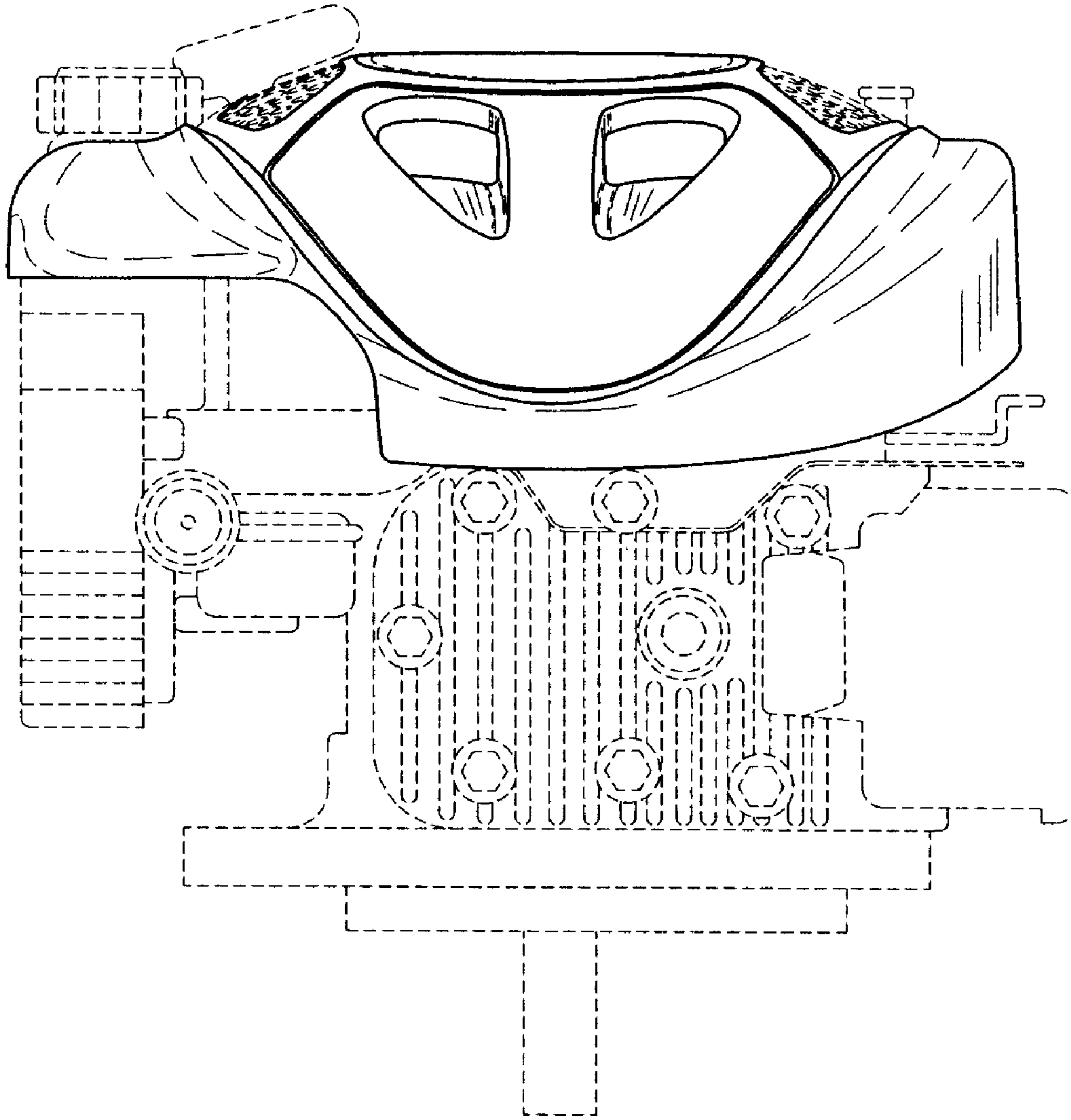

FIG. 4

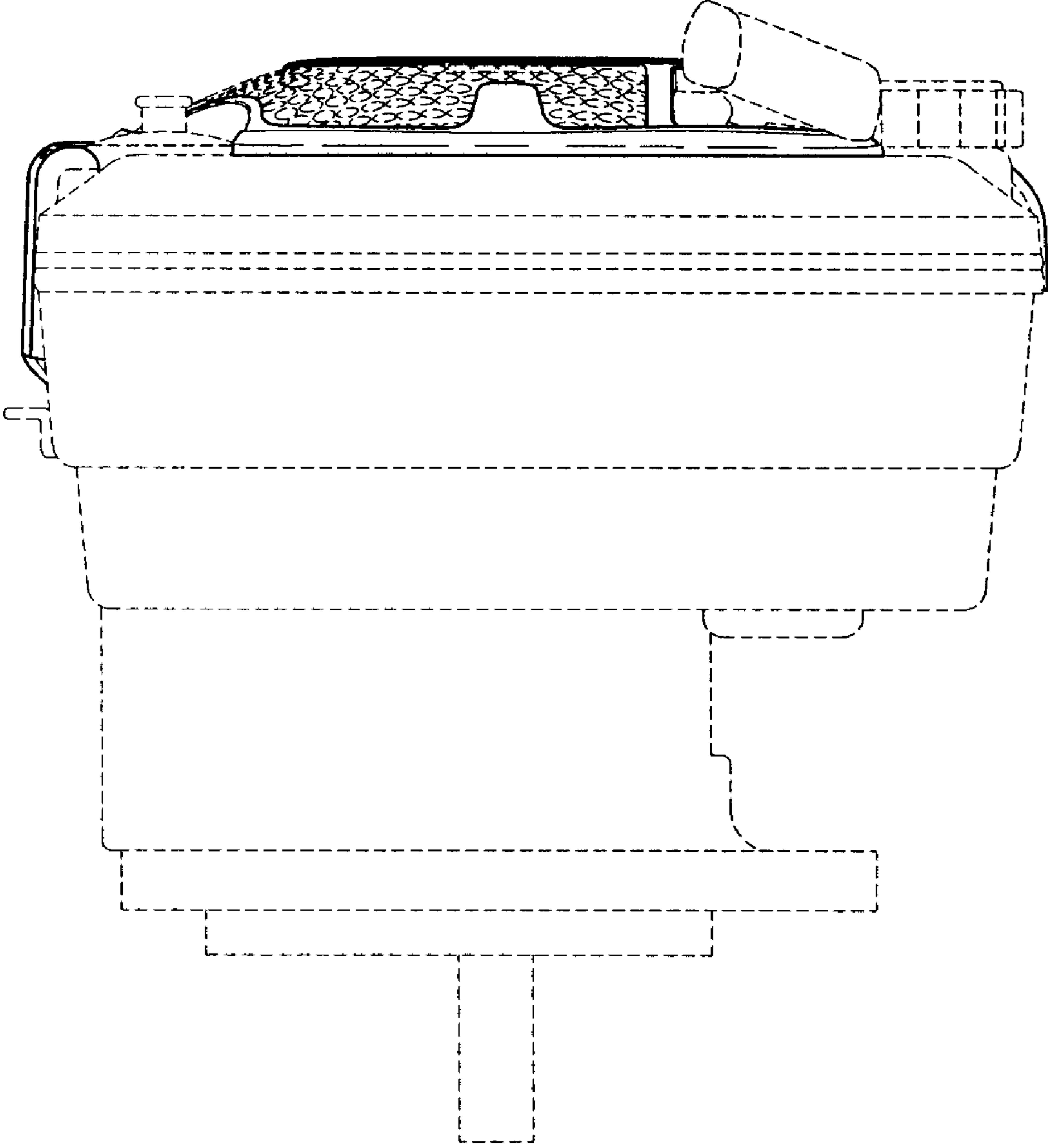

FIG. 5

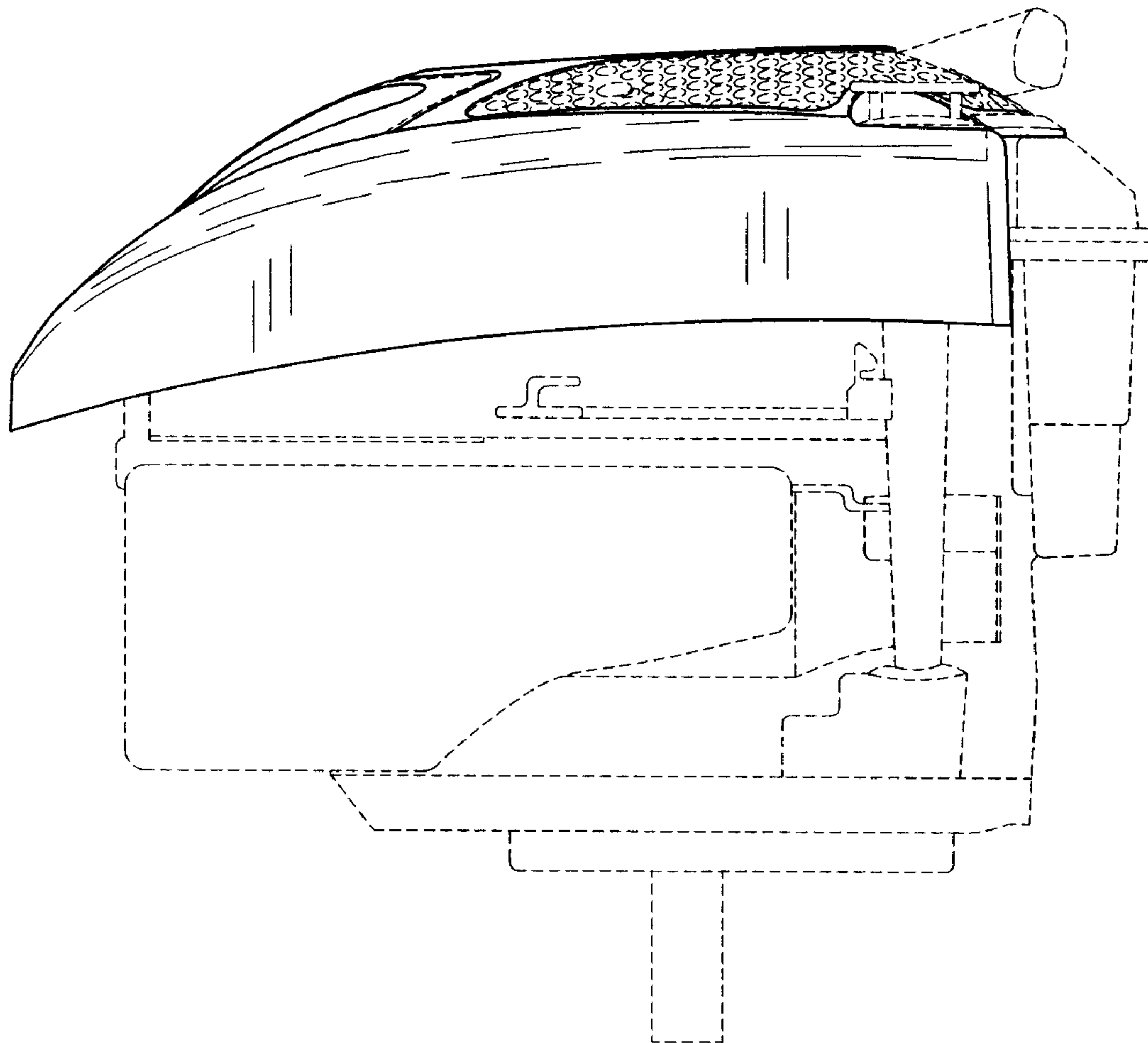

FIG. 6



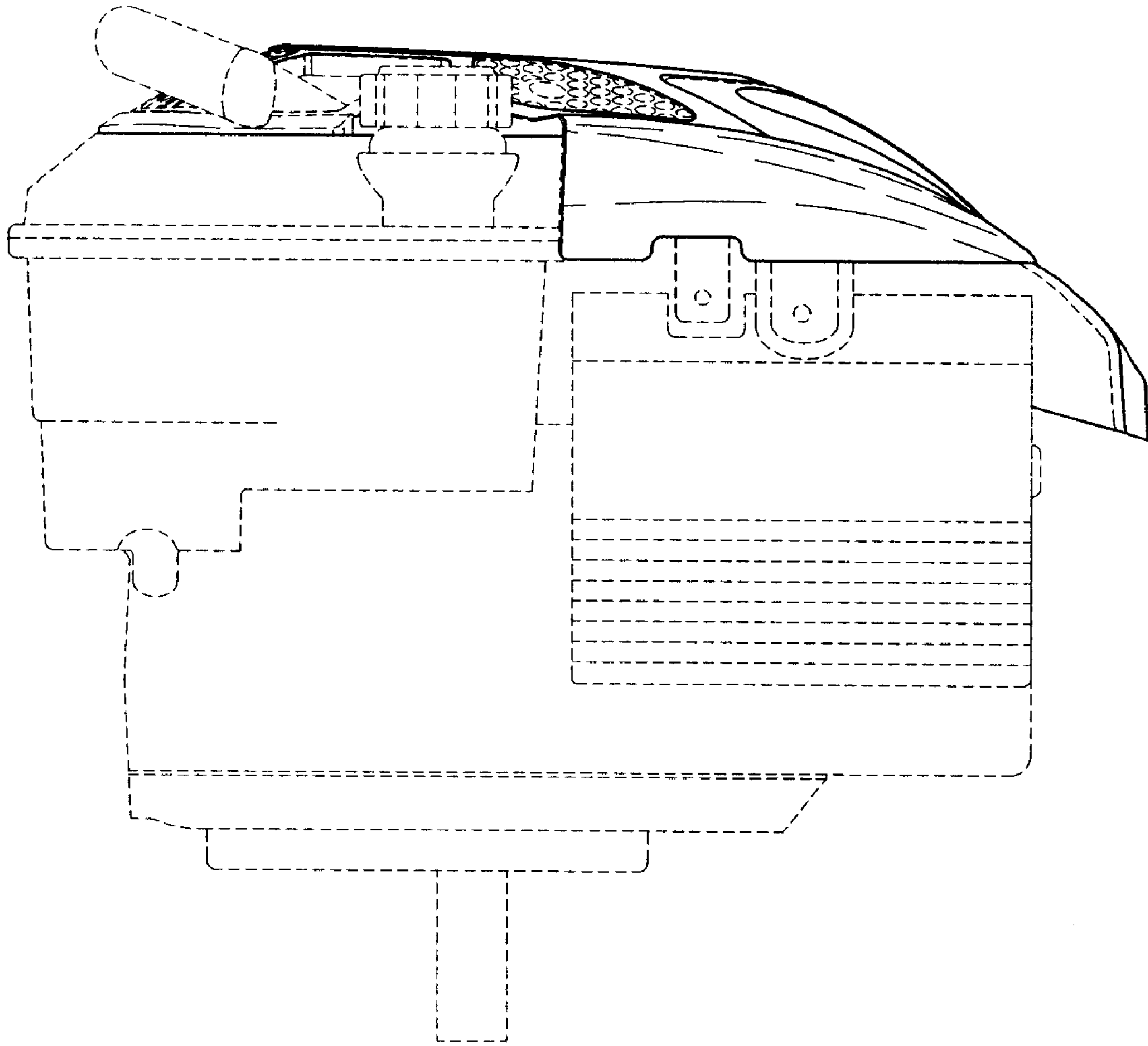

FIG. 7