



US00D512961S

(12) **United States Design Patent**
Okuda et al.

(10) **Patent No.: US D512,961 S**

(45) **Date of Patent: ** Dec. 20, 2005**

(54) **BATTERY PACK**

(75) Inventors: **Shinsuke Okuda, Anjo (JP); Kazuma Oshima, Anjo (JP); Yoichi Kato, Anjo (JP)**

(73) Assignee: **Makita Corporation, Aichi-Ken (JP)**

(**) Term: **14 Years**

(21) Appl. No.: **29/195,724**

(22) Filed: **Dec. 17, 2003**

(30) **Foreign Application Priority Data**

Jun. 24, 2003 (JP) 2003-021929
Jun. 24, 2003 (JP) 2003-021936

(51) **LOC (6) Cl. 13-02**

(52) **U.S. Cl. D13/103**

(58) **Field of Search** D13/103-104,
D13/106-108, 110, 118-119, 184; D14/188;
429/96-100, 163, 178

(56) **References Cited**

U.S. PATENT DOCUMENTS

D300,132 S * 3/1989 Culbertson et al. D13/103
D413,564 S * 9/1999 Hershberger et al. D13/103
D415,100 S * 10/1999 Buck D13/103
D436,917 S 1/2001 Hayakawa et al.
D456,002 S 4/2002 Kato

D460,412 S * 7/2002 Nawrozki D13/107
6,566,005 B1 * 5/2003 Shimma et al. 429/148
D475,679 S * 6/2003 Cooper et al. D13/103
D477,811 S * 7/2003 Niwa et al. D13/103
D478,608 S * 8/2003 Briks et al. D16/237
D481,672 S * 11/2003 Niwa et al. D13/103
D483,012 S * 12/2003 Hsu D13/103
6,783,886 B1 * 8/2004 Sakakibara et al. 429/99

* cited by examiner

Primary Examiner—Alan P. Douglas

Assistant Examiner—Rosemary Tarcza

(74) *Attorney, Agent, or Firm*—Dennison, Schultz,
Dougherty & MacDonald

(57) **CLAIM**

The ornamental design for a battery pack, as shown and described.

DESCRIPTION

FIG. 1 is a perspective view of a battery pack showing our new design.

FIG. 2 is a front elevation view thereof;

FIG. 3 is a rear elevation view thereof;

FIG. 4 is a left side elevation view thereof;

FIG. 5 is a right side elevation view thereof;

FIG. 6 is a top plan view thereof; and,

FIG. 7 is a bottom view thereof.

1 Claim, 4 Drawing Sheets

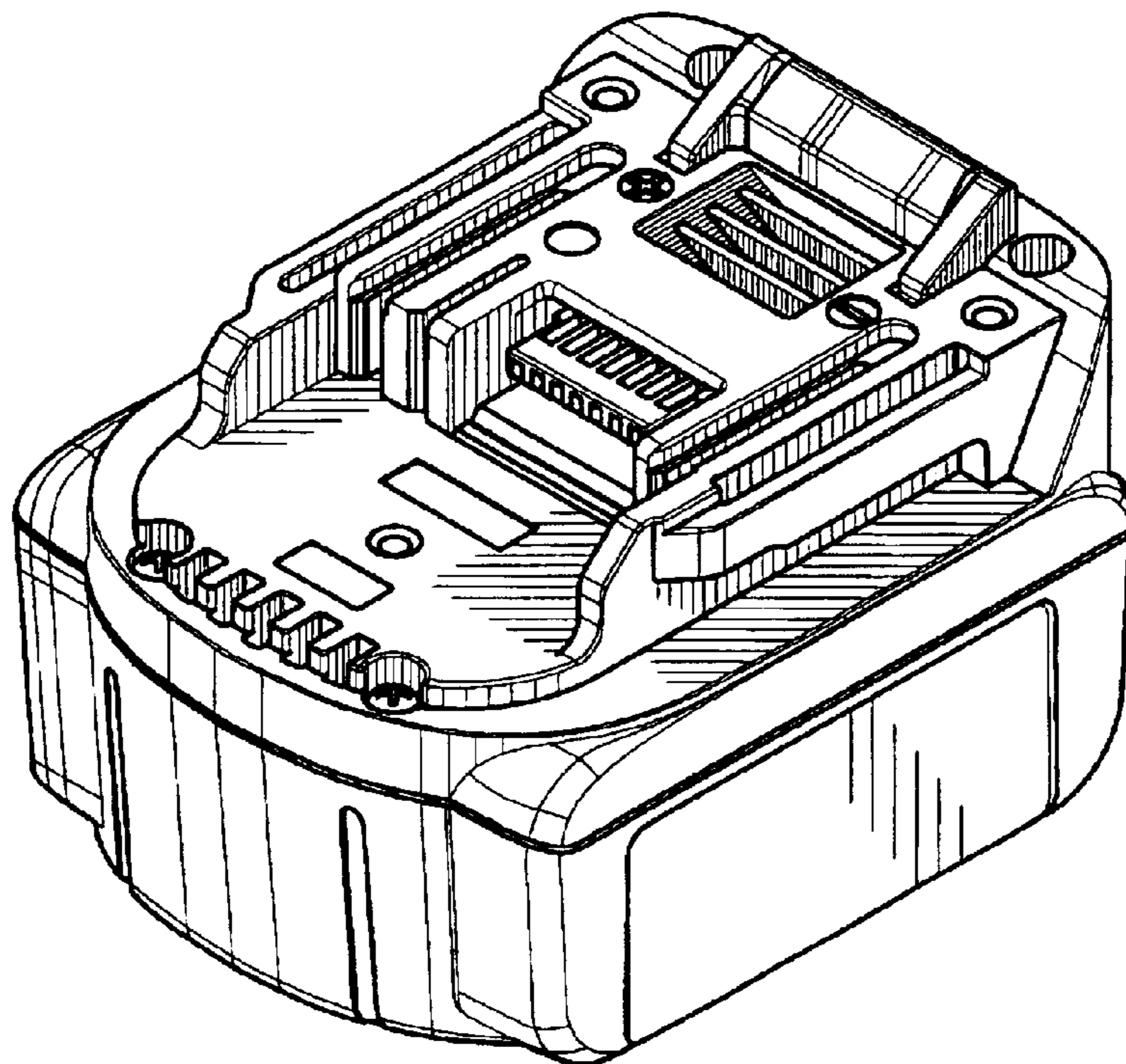

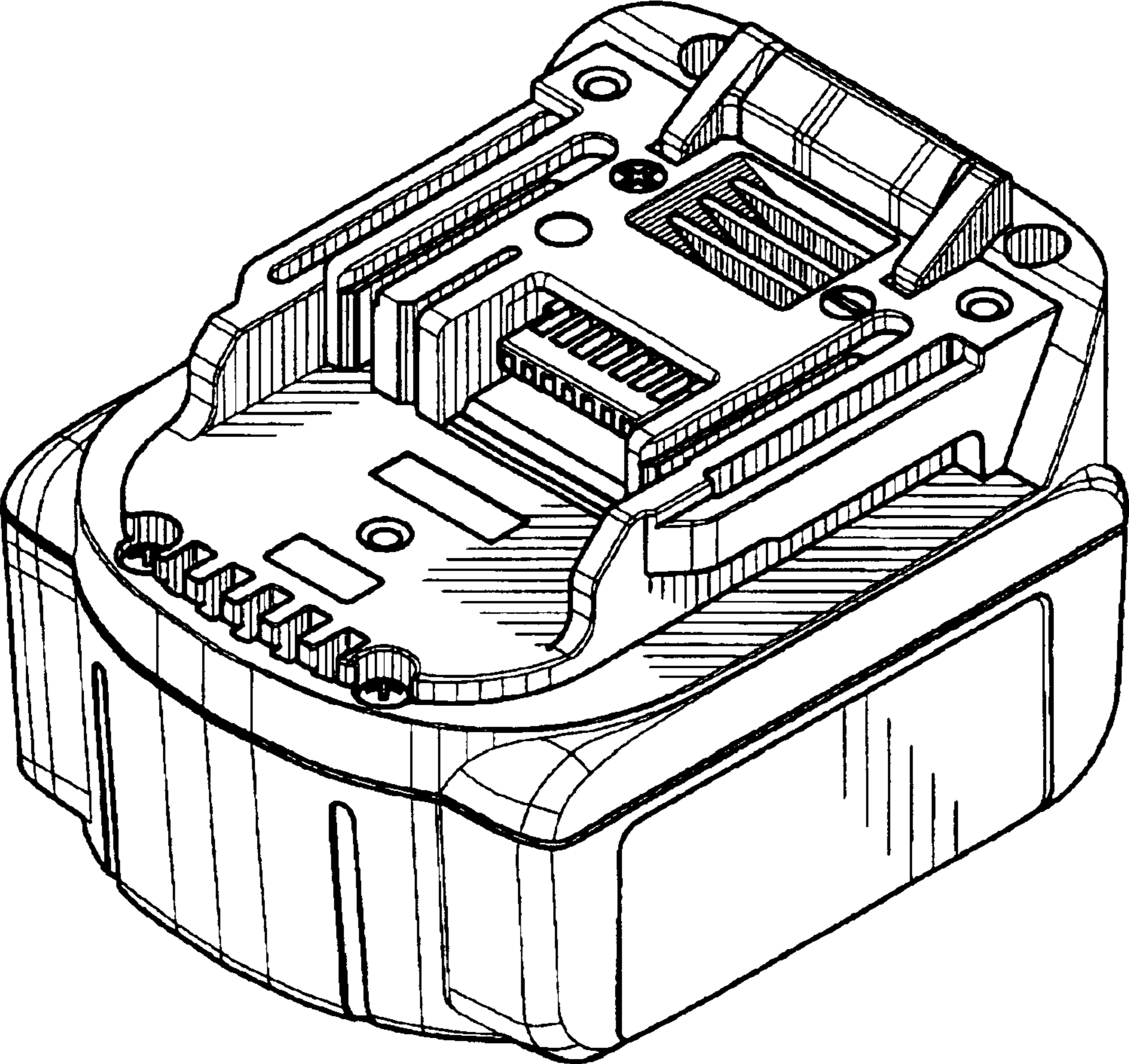

FIG. 1

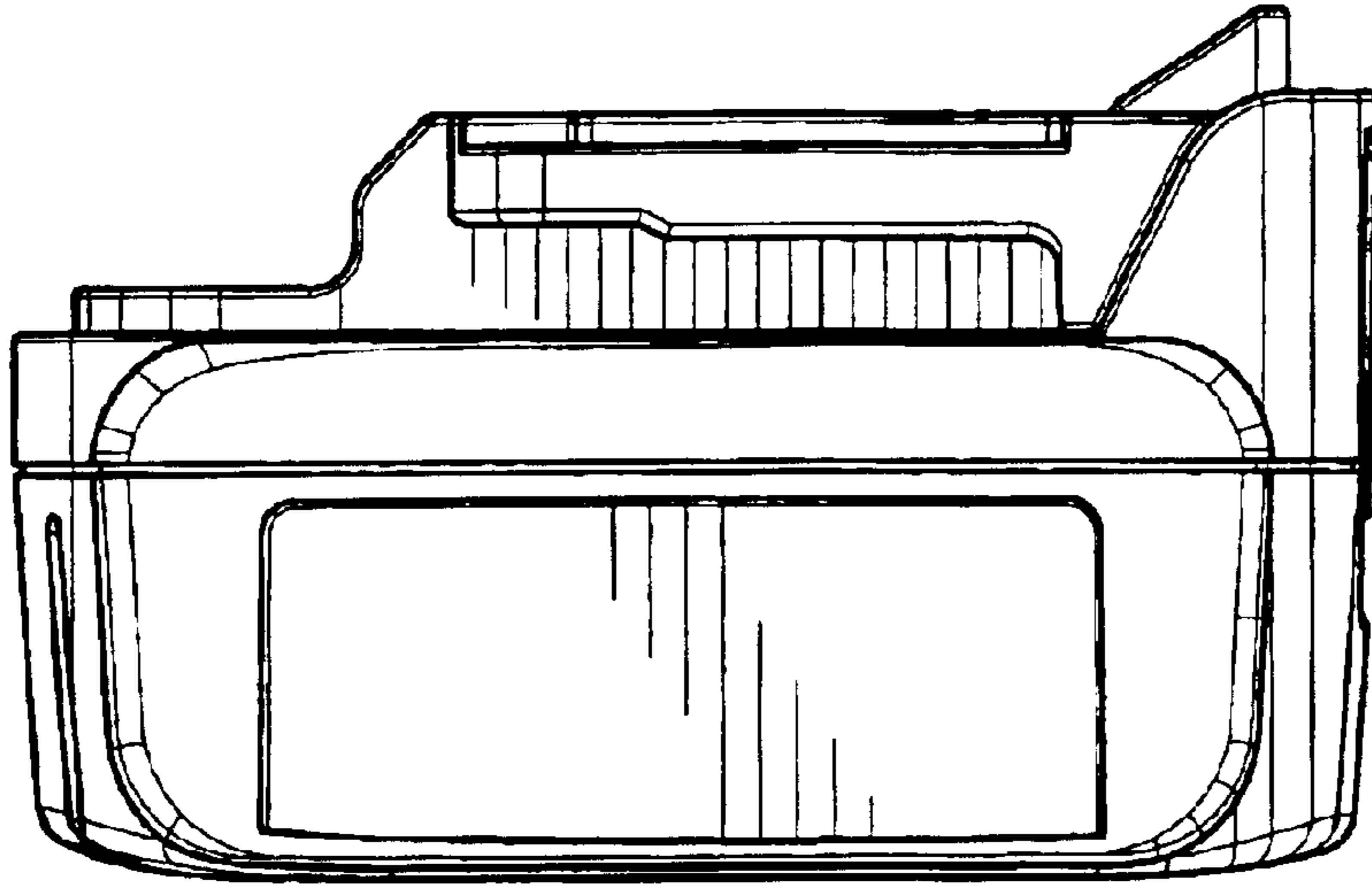

FIG. 2

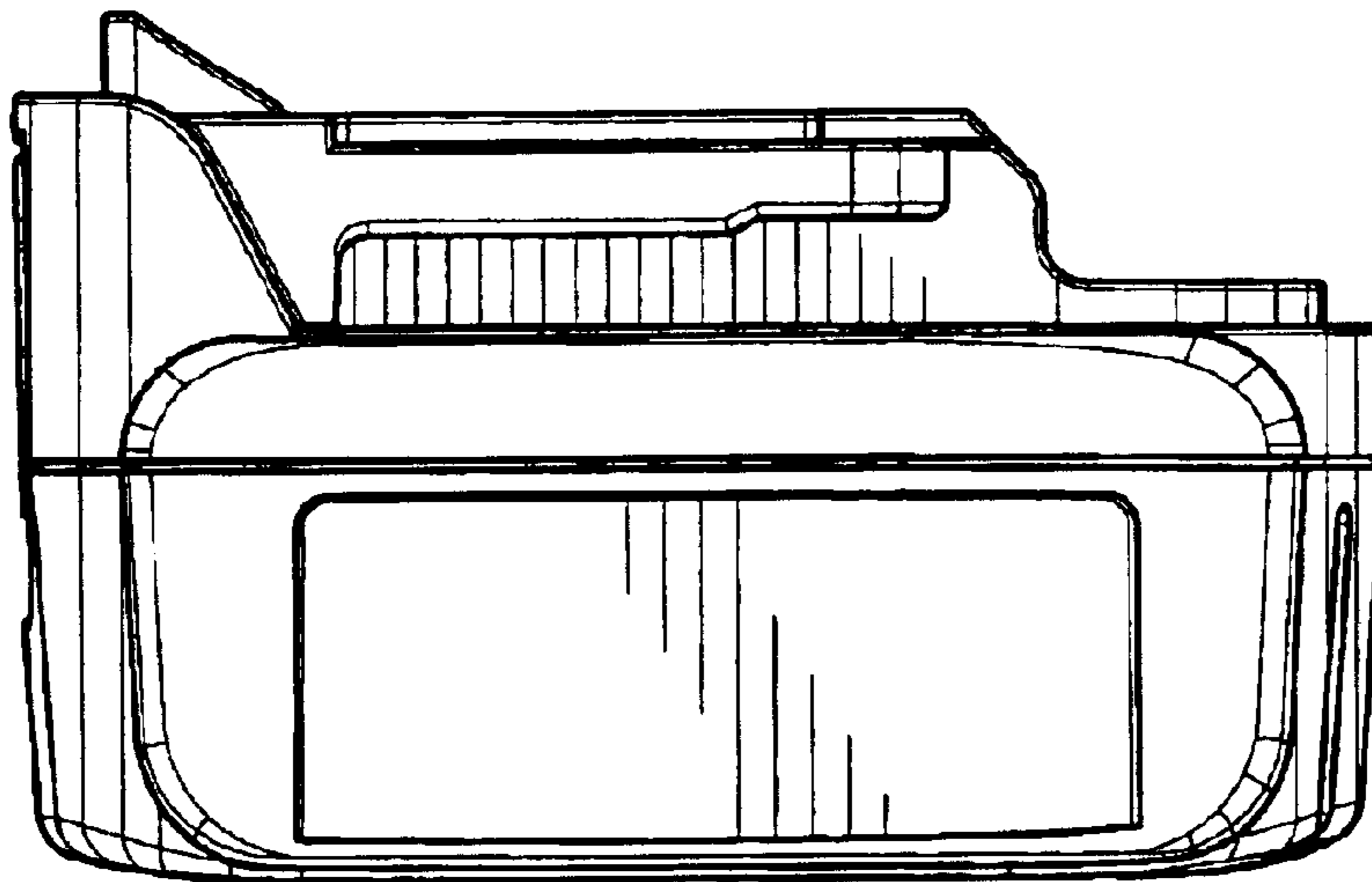

FIG. 3

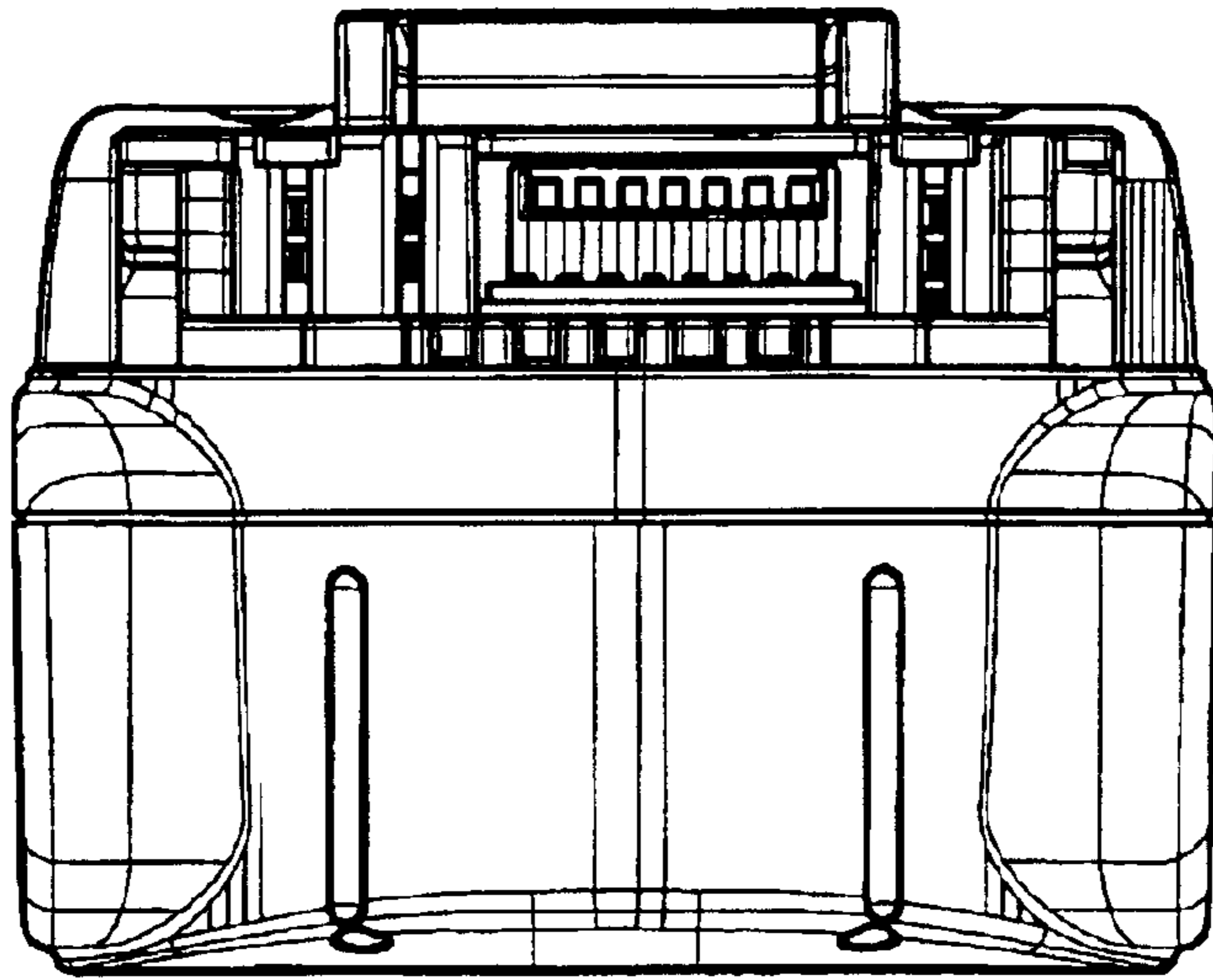

FIG. 4

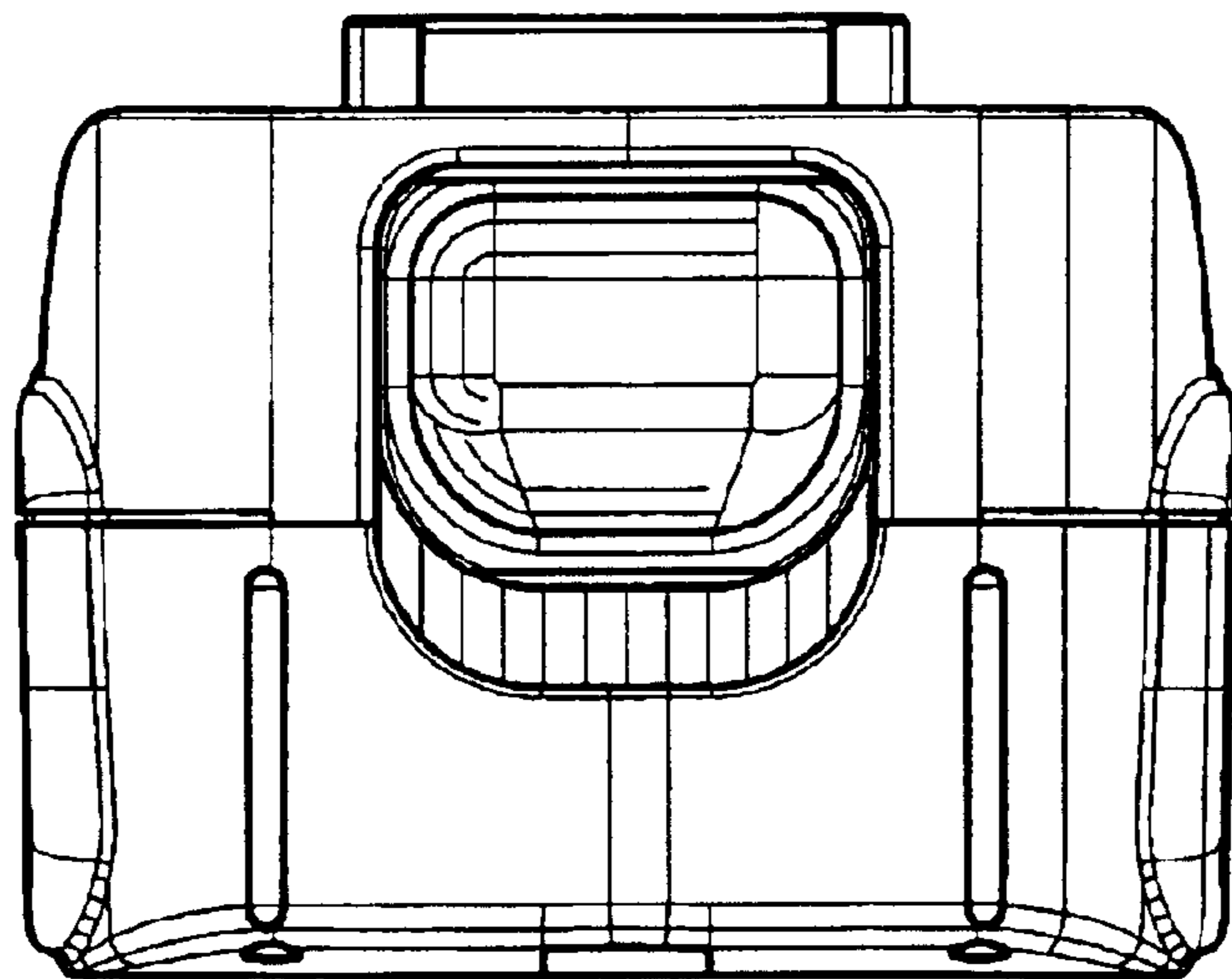

FIG. 5

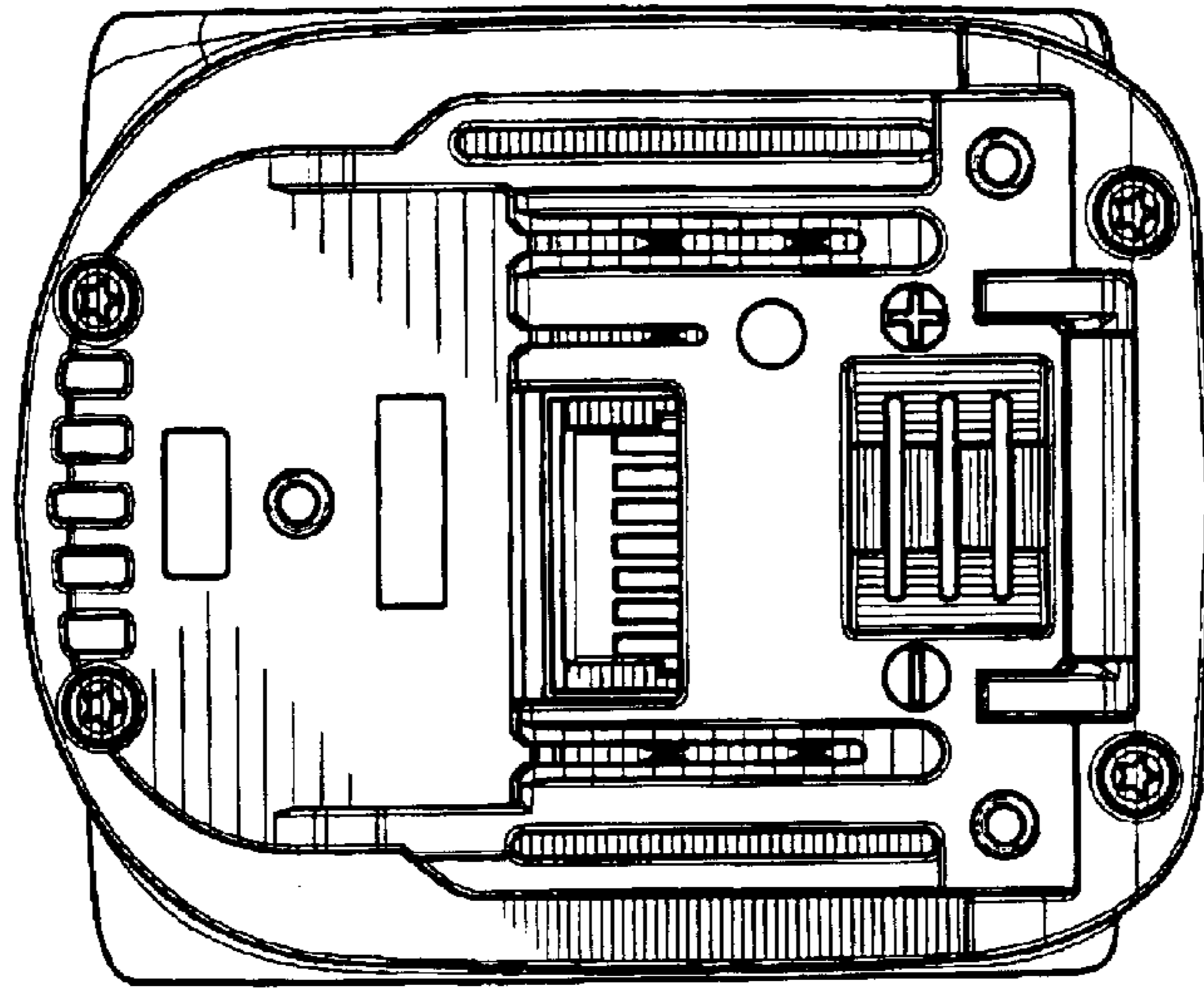

FIG. 6

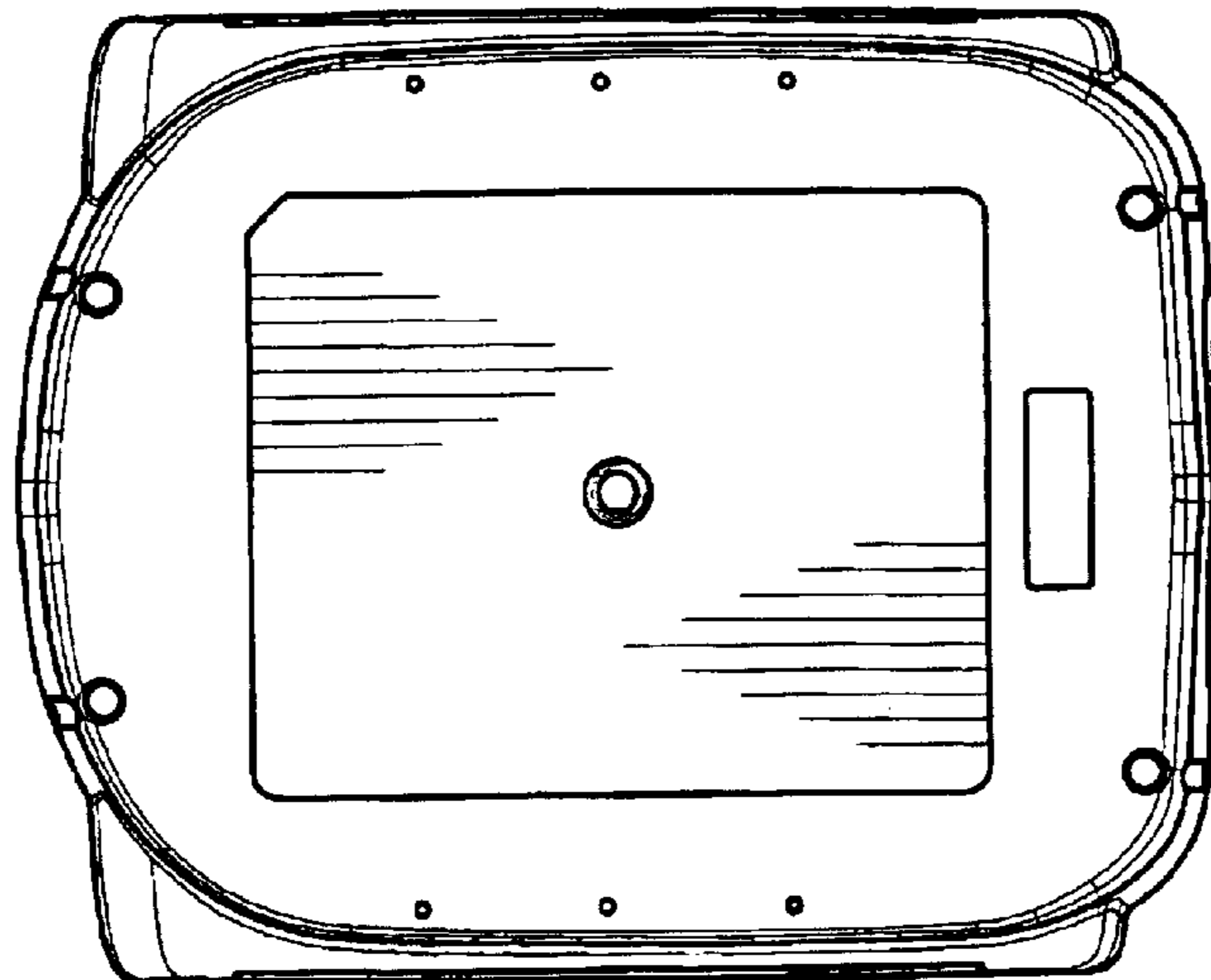

FIG. 7