



US00D512947S

(12) **United States Design Patent**
Buerlein

(10) **Patent No.:** **US D512,947 S**
(45) **Date of Patent:** **** Dec. 20, 2005**

(54) **MOTOR-VEHICLE-BODY EXTERIOR LOUVERS**

(76) **Inventor:** **Robert Alan Buerlein**, 4430 Menokin Rd., Richmond, VA (US) 23225

(**) **Term:** **14 Years**

(21) **Appl. No.:** **29/186,215**

(22) **Filed:** **Jul. 14, 2003**

(51) **LOC (6) Cl.** **12-16**

(52) **U.S. Cl.** **D12/196**

(58) **Field of Search** D12/196, 190,
D12/90-92, 86, 221; 296/180.1, 198, 50,
39.1, 39.2; 180/69.24, 68.6

(56) **References Cited**

U.S. PATENT DOCUMENTS

D316,072 S	*	4/1991	Wayne	D12/190
D351,580 S	*	10/1994	Montgomery	D12/196
D374,206 S	*	10/1996	Nagashima	D12/190
D375,068 S	*	10/1996	Lund	D12/183
D432,064 S	*	10/2000	Hartog	D12/190
D457,120 S	*	5/2002	Broccardo et al.	D12/223
D466,073 S	*	11/2002	Jurica et al.	D12/221
D478,854 S	*	8/2003	Platto et al.	D12/196
D482,992 S	*	12/2003	Hattori et al.	D12/184
D497,860 S	*	11/2004	Hoelzel et al.	D12/196

* cited by examiner

Primary Examiner—Melody N. Brown

(57) **CLAIM**

The ornamental design for a motor-vehicle-body exterior louver, as shown and described.

DESCRIPTION

FIG. 1 is a rear perspective of a motor-vehicle-body exterior louver showing my new design.

FIG. 2 is a front view thereof.

FIG. 3 is a rear view thereof.

FIG. 4 is a left side view thereof.

FIG. 5 is right side view thereof.

FIG. 6 is a top view thereof.

FIG. 7 is a bottom view thereof.

FIG. 8 is a rear perspective of a second embodiment of a motor-vehicle-body exterior louver showing my new design.

FIG. 9 is a front view of FIG. 8.

FIG. 10 is a rear view of FIG. 8.

FIG. 11 is a left side view of FIG. 8.

FIG. 12 is a right side view of FIG. 8.

FIG. 13 is a top view of FIG. 8.

FIG. 14 is a first top plan view of two motor-vehicle-body exterior louvers shown in environmental use.

FIG. 15 is a second top plan view of a motor-vehicle-body exterior louver shown in environmental use showing my new design; and,

FIG. 16 is a third top plan view of a motor-vehicle-body exterior louver shown in environmental use showing my new design.

1 Claim, 11 Drawing Sheets

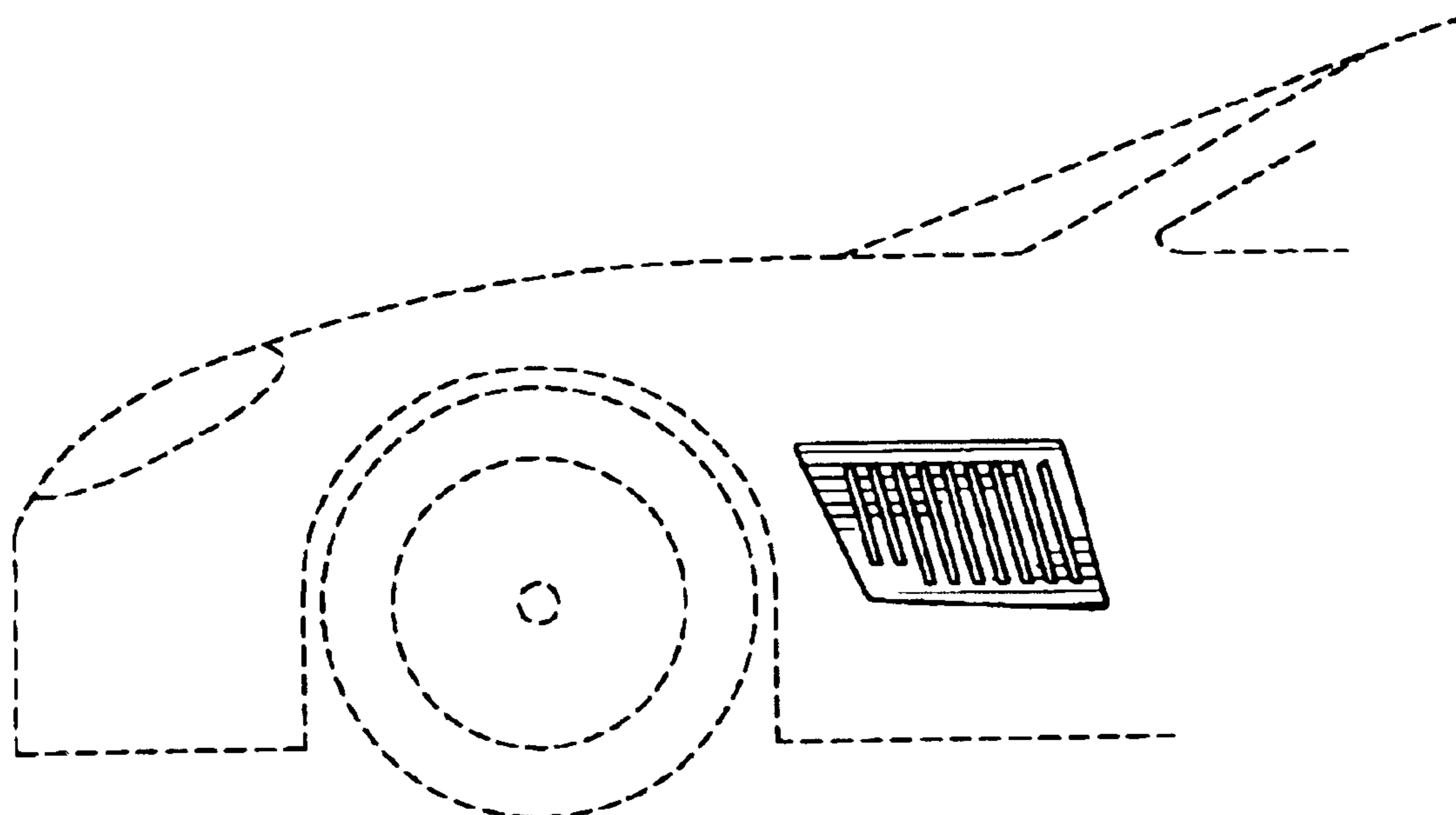

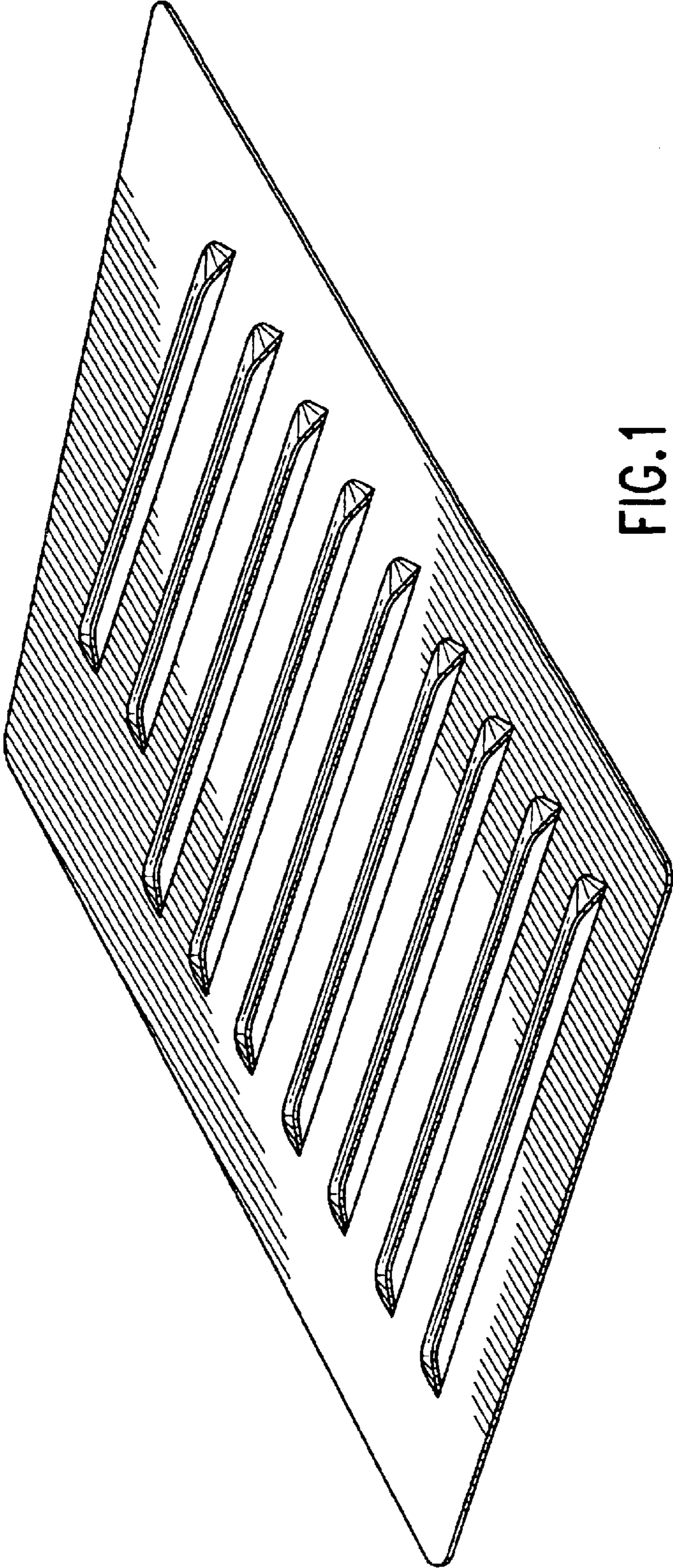

FIG.1

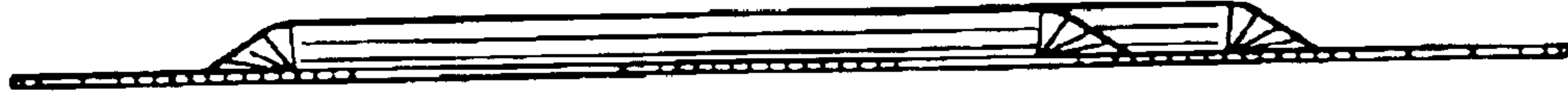

FIG. 2

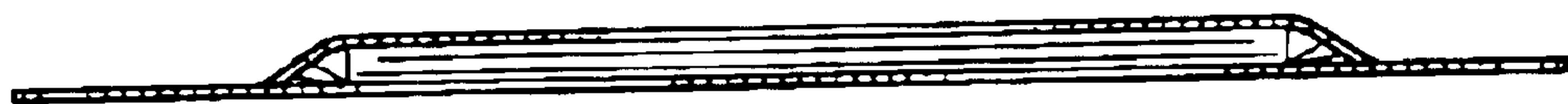

FIG. 3



FIG. 4



FIG. 5

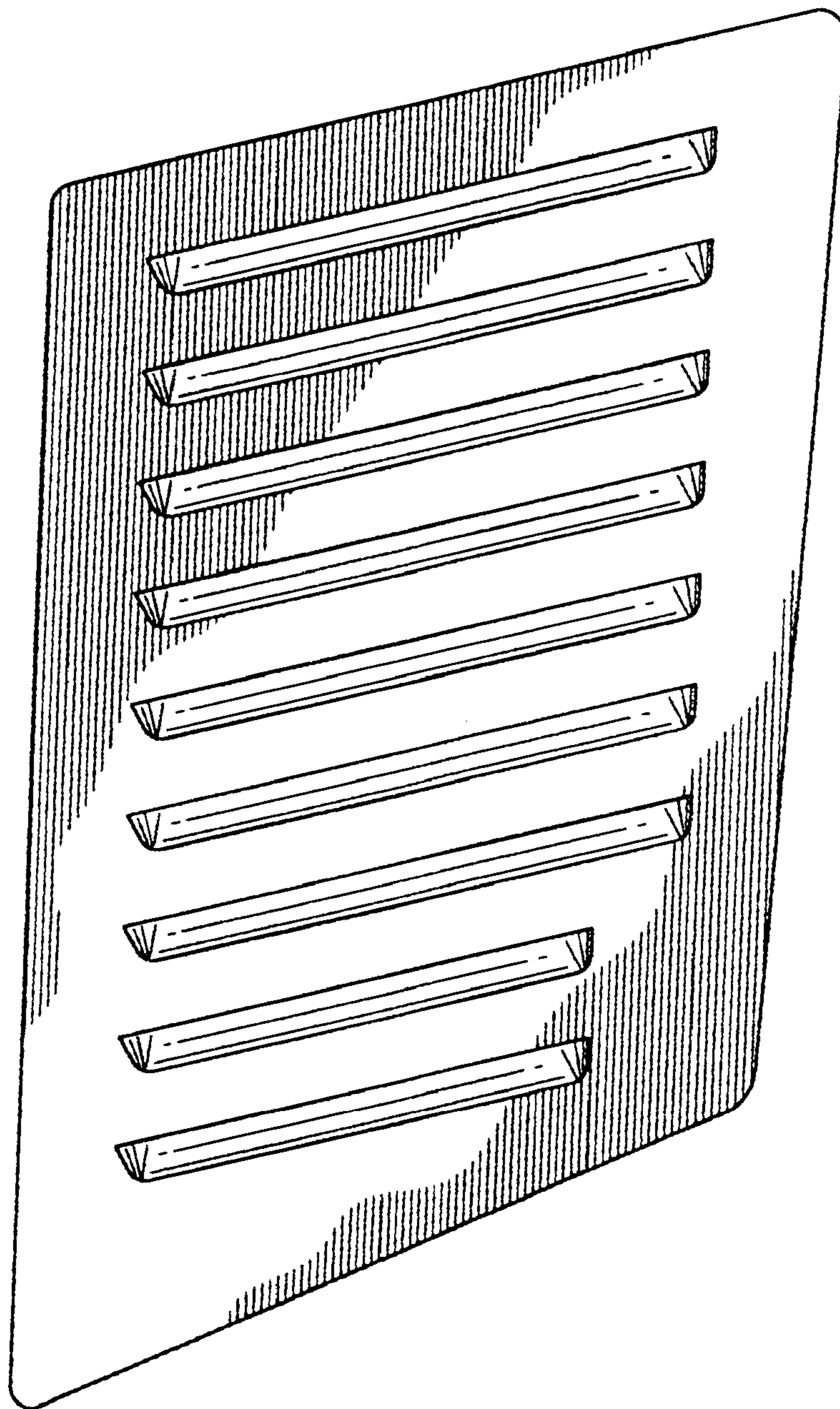

FIG. 6

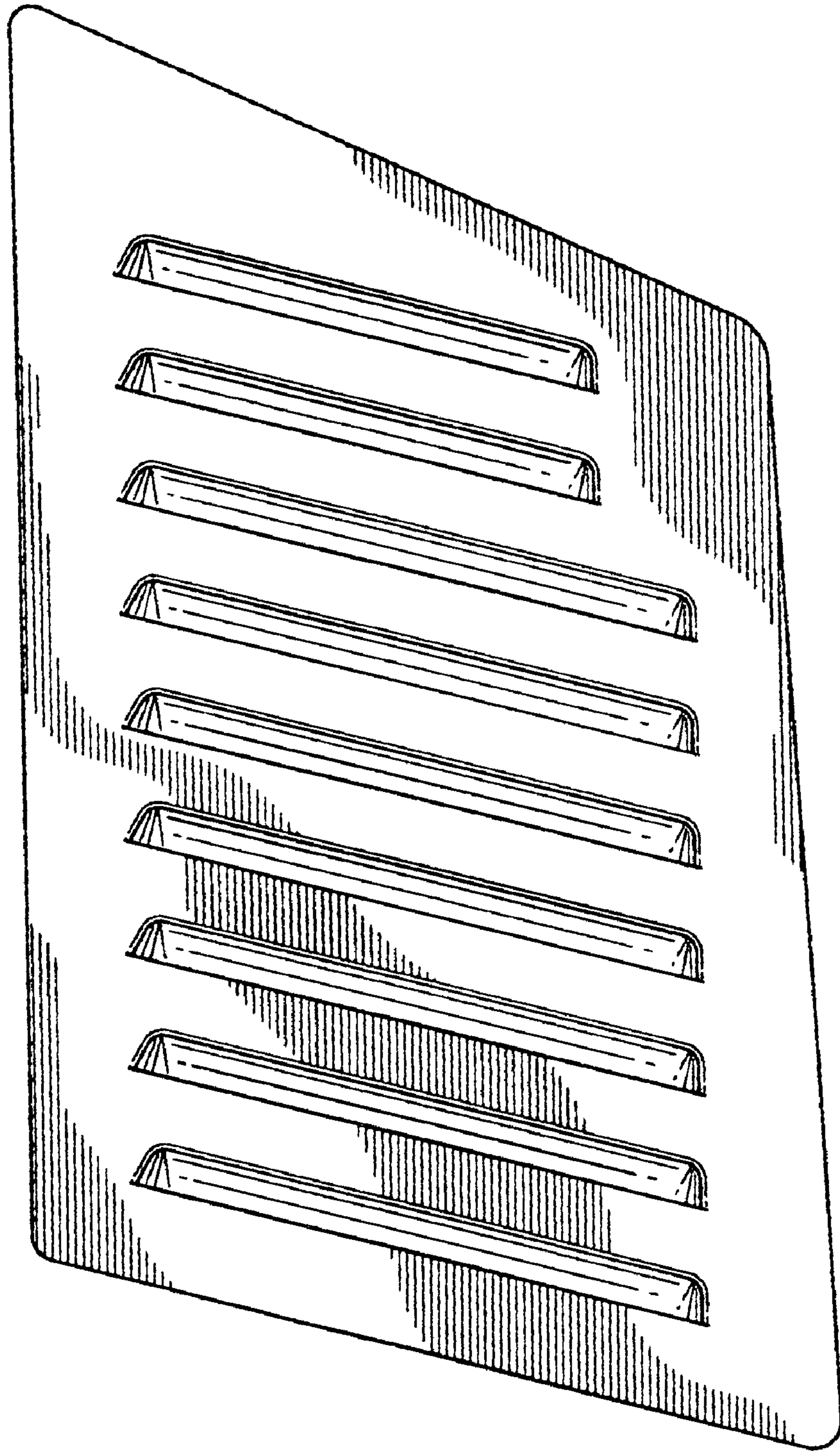

FIG.7

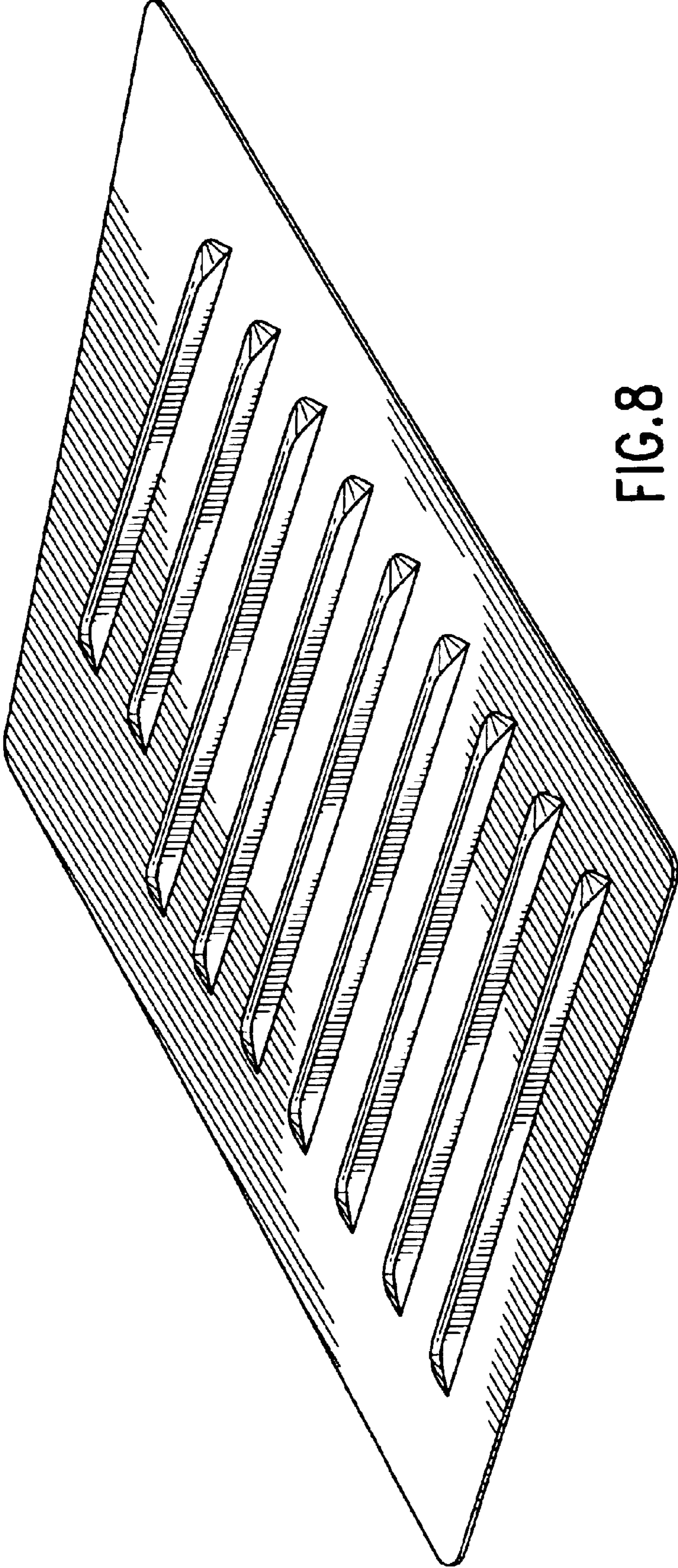

FIG.8

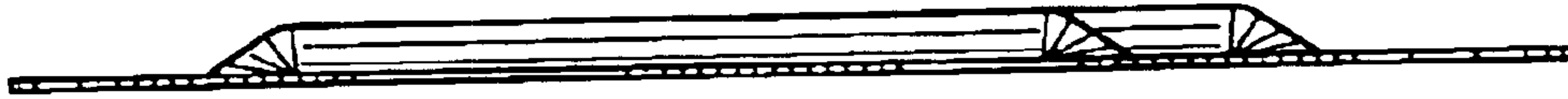

FIG. 9



FIG. 10



FIG. 11



FIG. 12

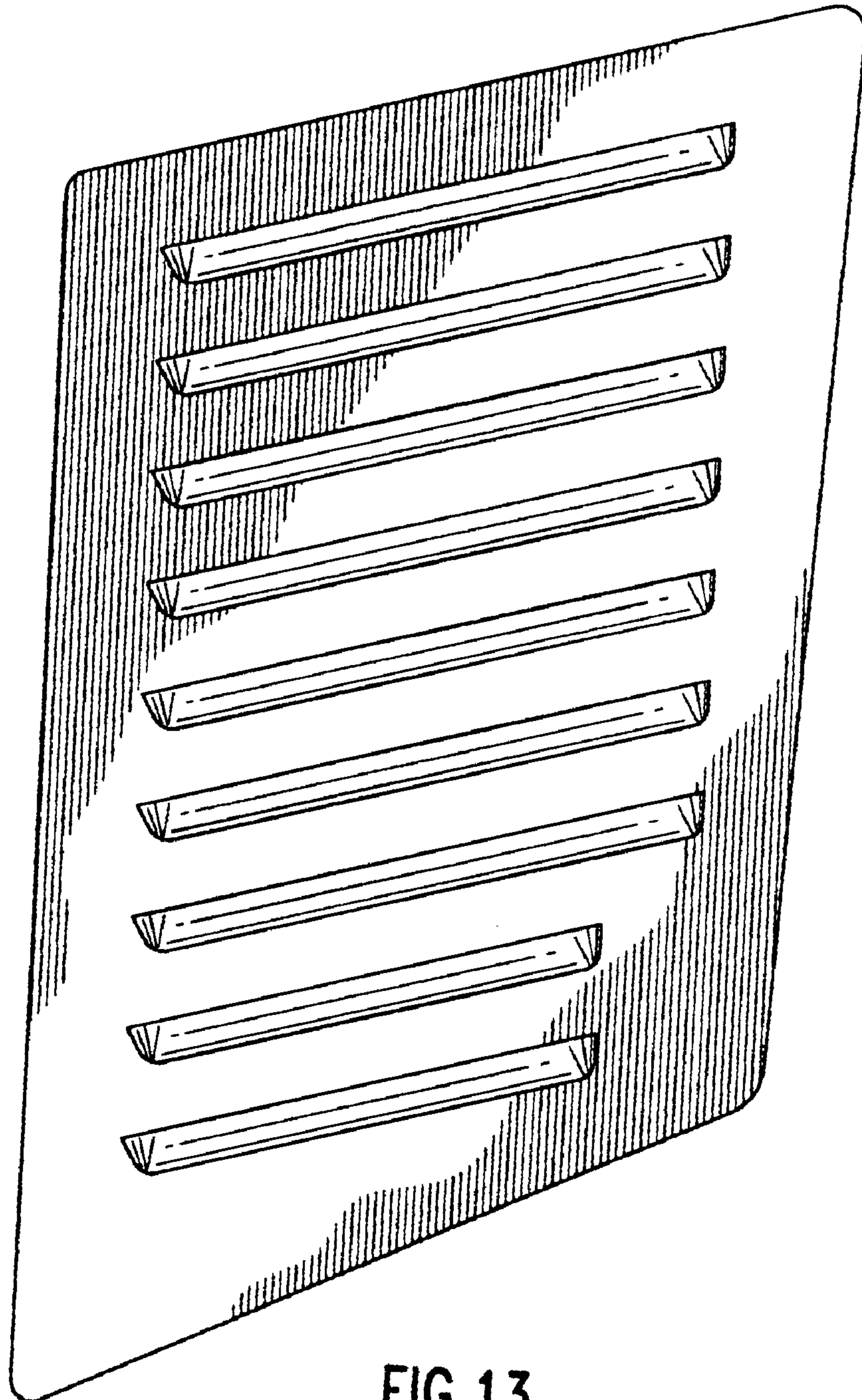

FIG. 13

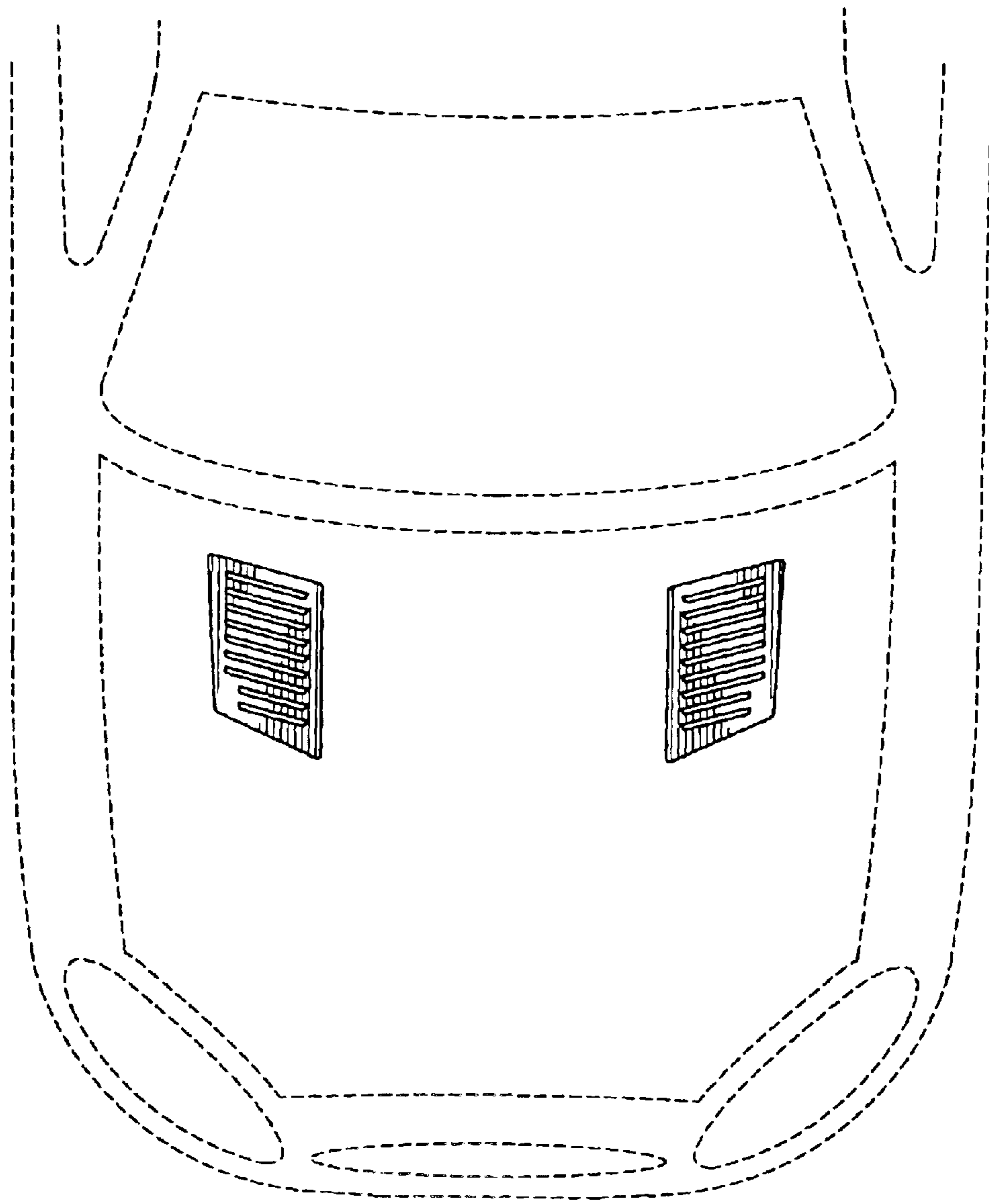

FIG. 14

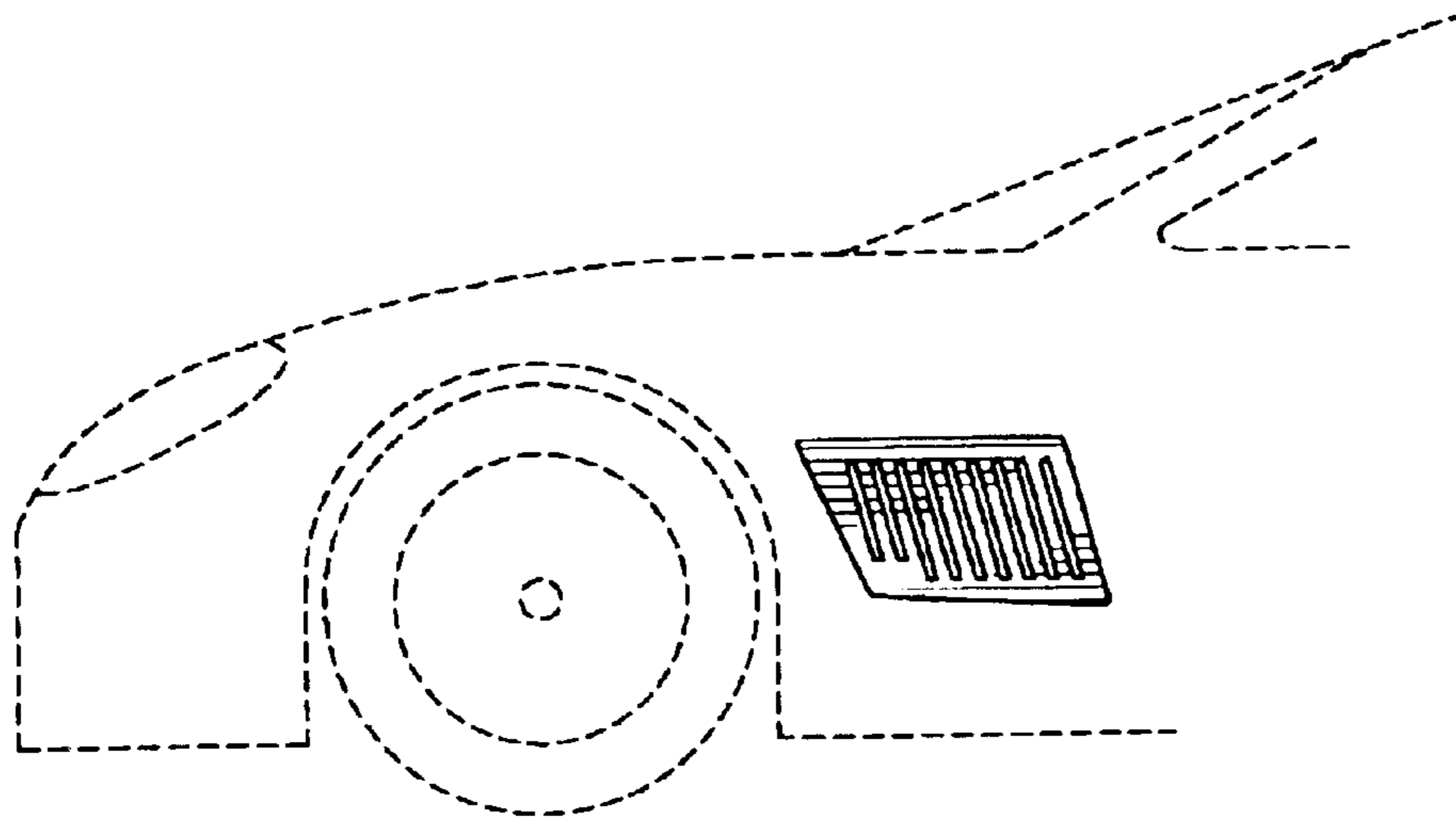

FIG.15

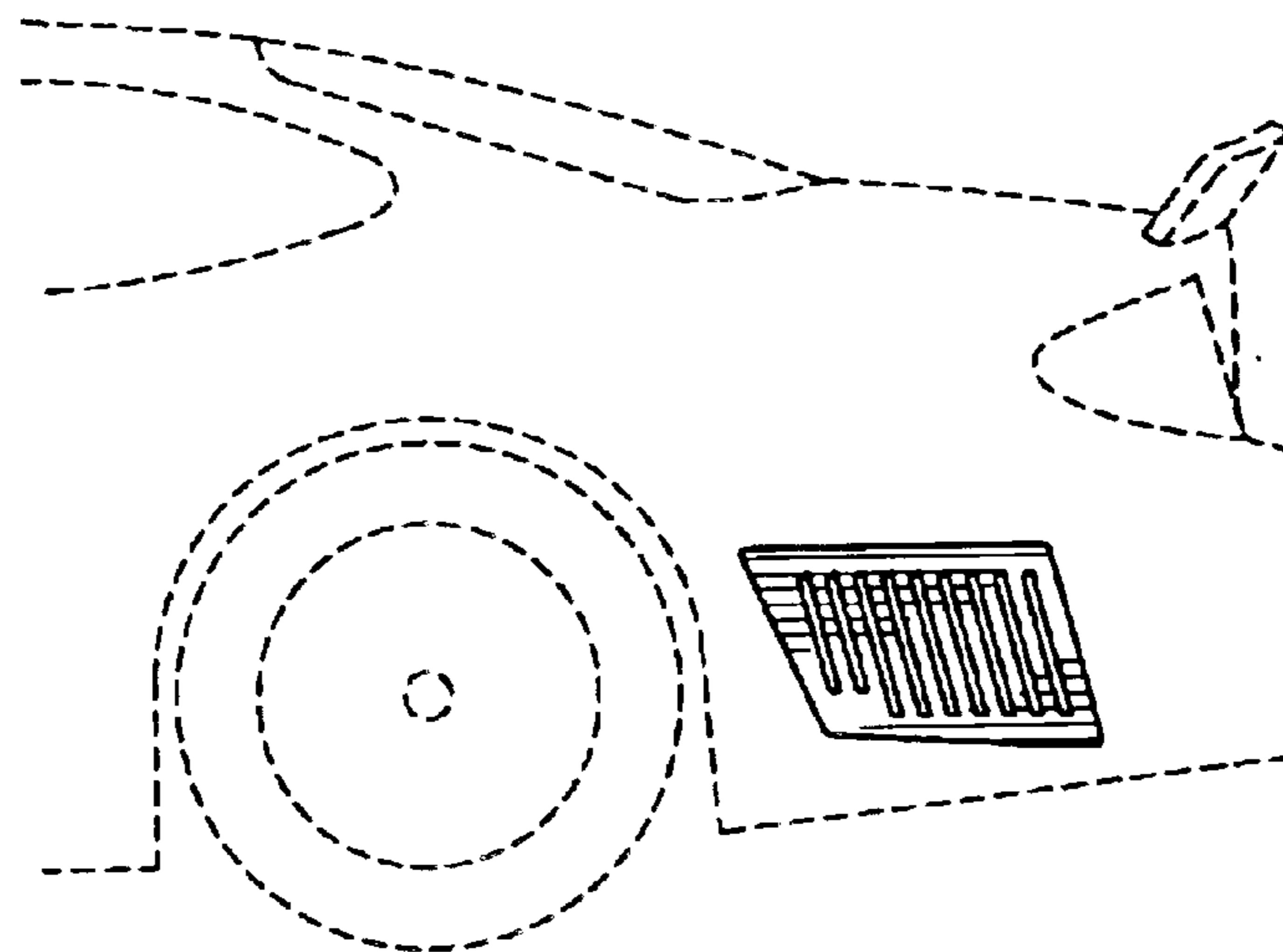

FIG.16