



US00D512904S

(12) **United States Design Patent**
Thaler

(10) **Patent No.: US D512,904 S**

(45) **Date of Patent: ** Dec. 20, 2005**

(54) **MOBILE ATTACHMENT DEVICE**
(75) Inventor: **Ken Thaler**, Parry Sound (CA)
(73) Assignee: **Thaler Metal Industries Ltd.** (CA)
(**) Term: **14 Years**

6,488,118 B1 * 12/2002 Corriveau 182/36
6,727,430 B1 * 4/2004 Franks, Jr. 174/51
D495,999 S * 9/2004 Lewis D13/154
D496,251 S * 9/2004 Buscart D8/356
D501,394 S * 2/2005 Franks et al. D8/356

(21) Appl. No.: **29/212,387**
(22) Filed: **Aug. 31, 2004**
(30) **Foreign Application Priority Data**

Jul. 7, 2004 (CA) 107546

(51) **LOC (6) Cl.** **08-05**
(52) **U.S. Cl.** **D8/356**
(58) **Field of Search** D8/356, 354, 394,
D8/367, 382, 383; 174/51; D13/154; 182/36,
45; 104/115; D34/35; 24/588.1, 598.2,
599.9, 600.1; 294/82.2

(56) **References Cited**

U.S. PATENT DOCUMENTS

D319,382 S * 8/1991 Hunter D8/356
5,224,427 A * 7/1993 Riches et al. 104/115
5,279,385 A 1/1994 Riches et al. 182/3
5,343,975 A 9/1994 Riches et al. 182/3
5,979,599 A * 11/1999 Noles 182/36
6,056,085 A * 5/2000 Cutter et al. 182/36
6,260,661 B1 * 7/2001 Cutter et al. 182/45
6,467,574 B2 * 10/2002 Lara 182/36
6,474,442 B1 * 11/2002 Atkinson et al. 182/36

OTHER PUBLICATIONS

Protecta International, "Ariana Technical Specifications AN700A," p. 8, Rev. Dec. 2001.

* cited by examiner

Primary Examiner—Ruth McInroy
Assistant Examiner—Terrence Huang
(74) *Attorney, Agent, or Firm*—Kusner & Jaffe

(57) **CLAIM**

The ornamental design for the mobile attachment device, as shown as described.

DESCRIPTION

FIG. 1 is a perspective view of a mobile attachment device showing my new design;
FIG. 2 is a top view thereof;
FIG. 3 is a right side view thereof;
FIG. 4 is an end view thereof;
FIG. 5 is a left side view thereof; and,
FIG. 6 is a bottom view thereof.
The broken lines in FIGS. 3–6 are for illustrative purposes only and form no part of the claimed design.

1 Claim, 2 Drawing Sheets

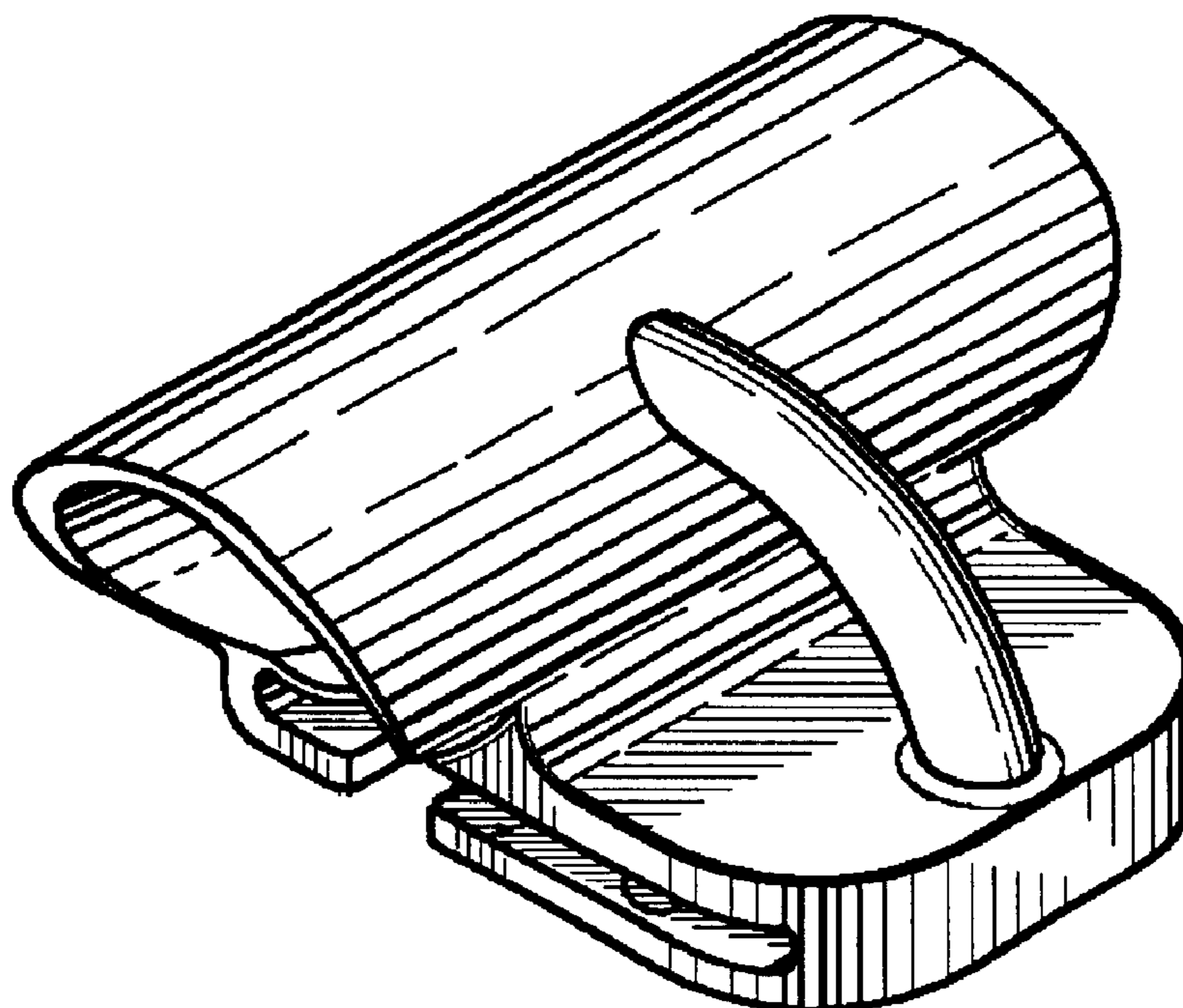

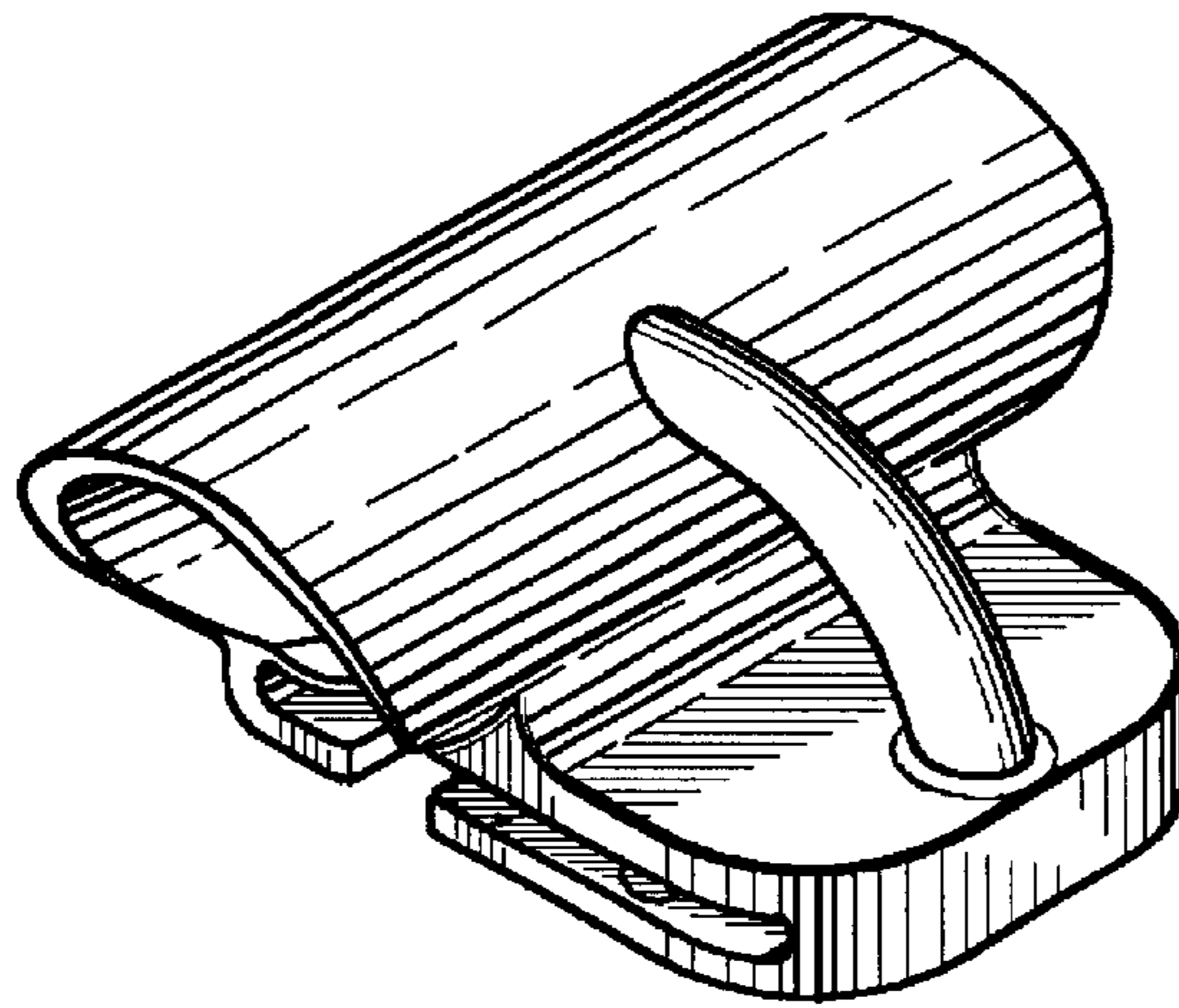

FIG. 1

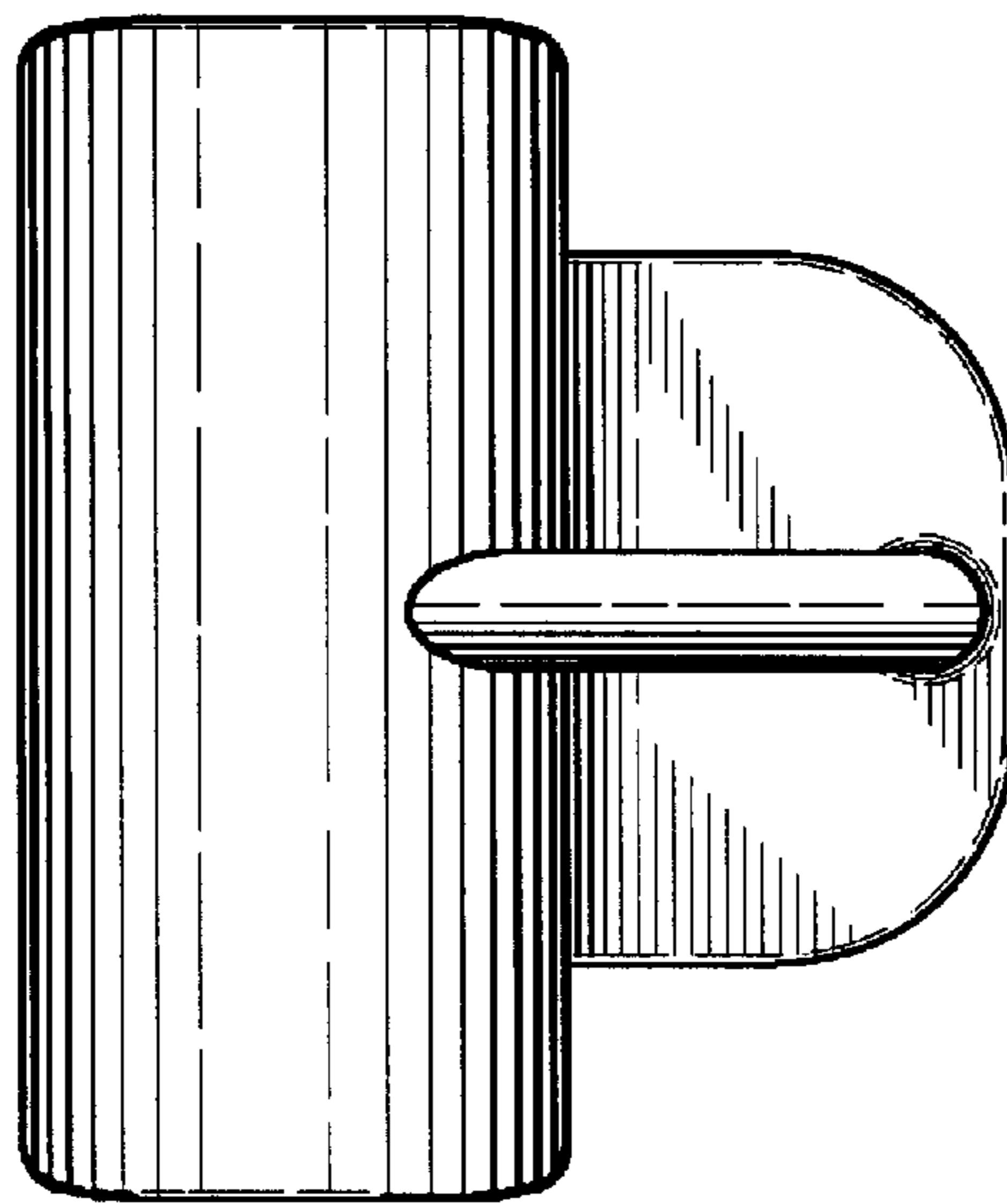

FIG. 2

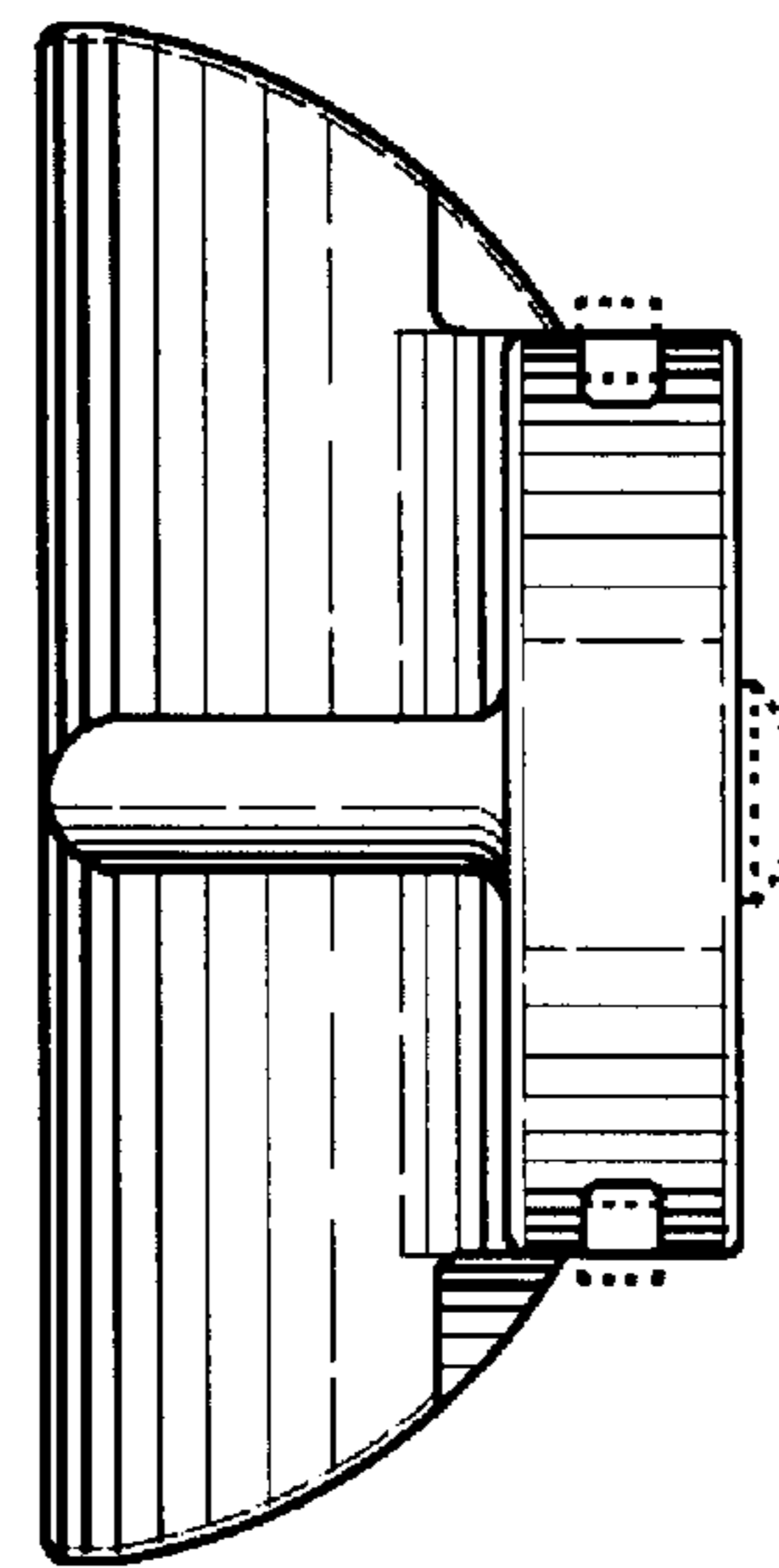

FIG. 3

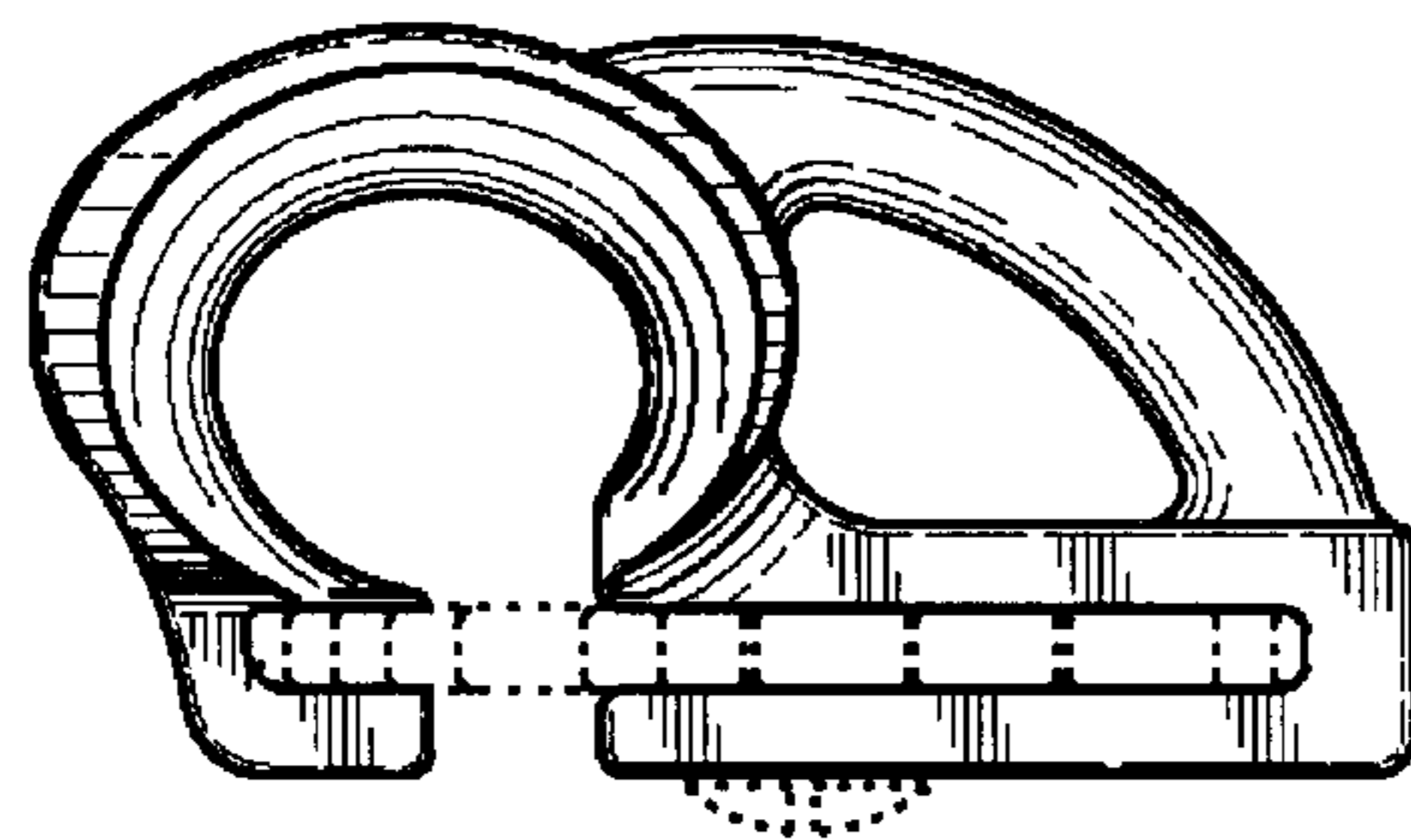

FIG. 4

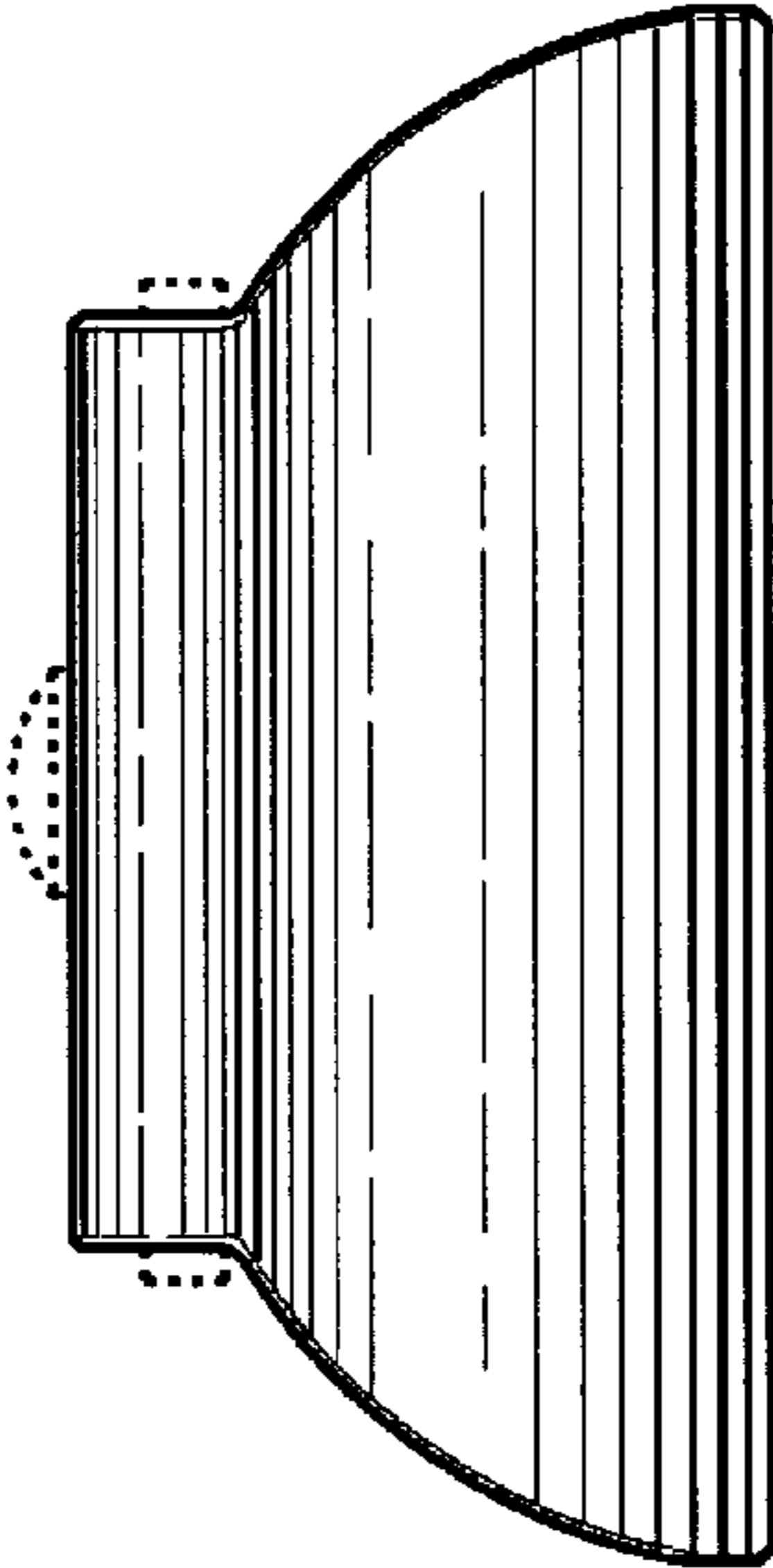

FIG.5

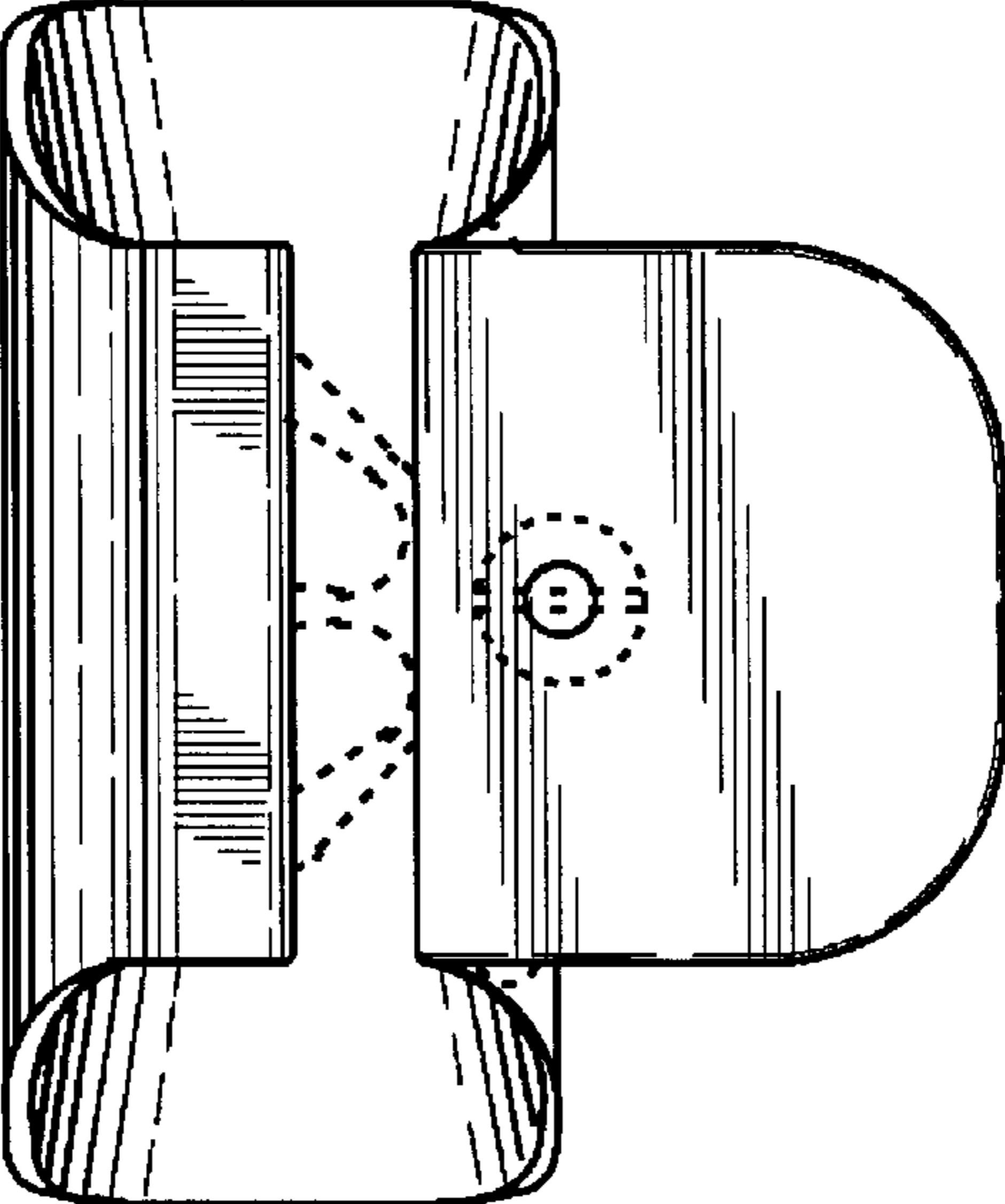

FIG.6